

STANLEY®

Engineered Fastening



ENGINEERED FASTENING SOLUTIONS

2017 Selection and
Configuration Guide

Quality, Productivity, Modularity = QPM

QPM Delivers Value Over the Life Cycle of the Product. Lowered Costs on Materials & Labor.

Reduced times for setup, fastening, rework, and maintenance.
Increased quality, productivity, ergonomics and flexibility.
Compared to pneumatic and other DC electric assembly tools,
QPM is the complete tightening solution that delivers lifetime
value. *QPM can improve ROI from a lower overall life cycle cost
as compared to pneumatic and other DC electric tool solutions.*



Quality

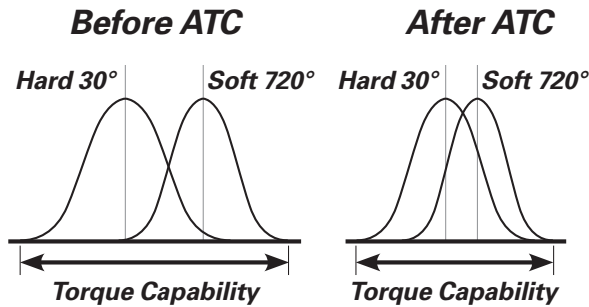

ATC Stanley's patented *Adaptive Tightening Control (ATC)* technology gives more consistent torque results by automatically adjusting for different joint rates.

Productivity



MTBF & MTTR

QPM systems reduce the frequency of maintenance with increased *Mean Time Between Failures (MTBF)* from long life components. Simple modular construction decreases the *Mean Time To Repair (MTTR)*.

Modularity & Flexibility



Common modular controllers and tool components allow a smaller inventory of interchangeable parts.

QPM enables flexible manufacturing. A single tool can be set to assemble joints of different target torque levels.

Error Proofing & Ergonomics

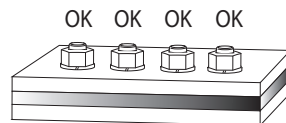

QPM compares fastening results to quality limits to eliminate missed fasteners.

QPM ATC prevents sudden downshifting which can reduce operator fatigue and torque reaction impulse.

Environment



QPM quietly and cleanly creates a better environment for your workers, their product and the globe.

Table of Contents

STANLEY

2	INTRODUCTION	62	INLINE RETRACTABLE	137	HEX, DEEP, SLIDING MAGNET
2	ABOUT STANLEY ASSEMBLY TECHNOLOGIES	67	OFFSET RETRACTABLE	138	HEX, DEEP, SLIDING MAGNET, THINWALL
2	OUR COMMITMENT TO QUALITY	70	EB SERIES QPM LEVER TOOLS	139	HEX, MAGNETIC SIDEWALL
3	ISO CERTIFICATION	71	ANGLE	140	HEX, DEEP, MAGNETIC SIDEWALL
3	CE COMPLIANCE	73	PISTOL	141	HEX, SHORT, MAGNETIC SIDEWALL
4	ERGONOMIC BY DESIGN	74	INLINE PUSH-TO-START	142	12-POINT, DEEP, SLIDING MAGNET
4	PREVENTIVE MAINTENANCE	74	INLINE	143	SPECIALS
5	REPAIR SERVICE	76	CROWFOOT	143	QUICK CHANGE
5	RECALIBRATING TOOLS	77	TUBENUT	143	EXTENSIONS/ ADAPTERS
5	TRAINING	78	HOLD AND DRIVE	146	TORX
5	TECHNICAL SUPPORT	80	EB SERIES QPM FIXTURED TOOLS	146	TORX
5	PARTNERING	81	ANGLE	147	BIT HOLDERS
6	CATALOG GUIDE & HOW TO ORDER	82	ANGLE RETRACTABLE	147	BITS
6	TOOL SPEEDS	84	INLINE	148	TAPER-LOK™ IMPACT SOCKETS
6	TOOL WEIGHTS	86	INLINE RETRACTABLE	148	3/8" DRIVE
6	TOOL CONFIGURATION	88	OFFSET RETRACTABLE	149	1/2" DRIVE
7	TOOL NUMBERS & LABELING INFORMATION	90	EA/ EB/ EC SERIES	150	3/4" DRIVE
8	TOOL POWER SOURCES	91	E SERIES	151	CROWFOOT/ TUBENUT STANDARD SOCKET SELECTION
8	TOOL CONTROL METHODS	92	ENGINEERED SYSTEMS	152	CROWFOOT/ TUBENUT SPECIAL SOCKET SELECTION
9	TOOL GEOMETRY	94	TURNKEY SYSTEM DESIGN	161	FLUSH ANGLE STANDARD SOCKET SELECTION
12	TIGHTENING TECHNIQUE	94	SYSTEMS IN ACTION	162	FLUSH ANGLE SPECIAL SOCKET SELECTION
12	TORQUE	95	CONTROL STRATEGIES	165	HOLD AND DRIVE SOCKET, BIT & TANG OPTIONS
12	ACCURACY	95	CUSTOM CONFIGURATIONS	165	LH18
13	ACCURACY	96	COMPONENTS	165	LH22
14	QB ALPHA CONTROLLERS	97	VERTICAL BALANCERS	168	LH26
14	QB ALPHA	98	TORQUE TUBES	170	LH32
15	HOW TO ORDER	101	ARTICULATING ARMS	171	TDM
16	BASIC	106	OVERHEAD BRIDGES	173	ACCESSORIES
17	STANDARD	109	PEDESTALS	173	MOUNTING OPTIONS
18	ADVANCED	110	AA QPM LEVER TOOLS	173	REACTION BARS
20	EXPERT	111	ANGLE	174	TOOL BAILS
22	NODE	112	INLINE	174	GEAR CASE EXTENSIONS
23	NETWORK NODE	113	HOLD AND DRIVE	175	GUIDED COLLARS
24	SPINDLE DISCONNECT	114	CROWFOOT	176	PINCHPOINT PROTECTORS
25	B SERIES QPM CORDLESS TOOL	115	REPAIR ACCESSORIES	176	PROTECTIVE HEAD COVERS
26	PISTOL	116	PNEUMATIC TOOL PROCESS QUALIFIER	177	LEVER HANDLE OPTIONS
27	ANGLE	118	PNEUMATIC TRANSDUCER TOOL CONTROLLER	177	TOOL LED HEADLIGHT
28	TUBENUT	120	PSI - INTELLIGENT AIR TOOLS	178	SOCKET TRAYS
28	CROWFOOT	120	THE PSI FAMILY	179	TEST FIXTURES
29	HOLD AND DRIVE	121	APPLICATION OF PULSE TOOLS	179	TORQUE VALIDATION MODULE
30	E AND EA SERIES QPM LEVER TOOLS	122	APPLICATION REFERENCE CHART	180	PSI-A
31	ANGLE	123	HYDRAULIC PULSE TOOLS	180	DC START HANDLE
35	PISTOL	123	MECHANICAL PULSE TOOLS	180	AUXILIARY HANDLE
37	SWING BAR PISTOL	124	ANGLE CONTROL PULSE TOOLS	181	FLOOR STANDS
38	INLINE PUSH-TO-START	125	PIN CLUTCH IMPACT TOOLS	182	MAINTENANCE TOOLS
38	INLINE	126	TWIN HAMMER IMPACT TOOLS	183	PSI ACCESSORIES
42	CROWFOOT	127	PSI CABLES & HOSES	184	INDEX
48	TUBENUT	129	PRIME MOVERS		
52	HOLD AND DRIVE	132	HEADLIGHT AIM TOOLS		
54	E SERIES QPM FIXTURED TOOLS	133	eCo-DRIVE SOCKETS & EXTENSIONS		
55	ANGLE RETRACTABLE	133	HEX, FAST-LEAD		
58	INLINE	135	HEX, FAST-LEAD, DEEP		
60	CROWFOOT	136	HEX, FAST-LEAD, DEEP THINWALL		
61	HOLD AND DRIVE				

Engineered Fastening Solutions

STANLEY Assembly Technologies was founded in 1963 as a division of The STANLEY Works.

Originally named STANLEY Air Tools, the group was renamed in 2002 to reflect the emphasis on our ability to employ technology to deliver solutions of high value to customers. In March 2010 The STANLEY Works acquired Black & Decker and became STANLEYBlack&Decker, Inc. STANLEY Assembly Technologies was attached to Emhart Teknologies to form a new business sector within STANLEYBlack&Decker known as “Engineered Fastening”.

The headquarters of STANLEY Assembly Technologies is located in Cleveland, Ohio where we are proud to say our products are “Assembled in America with Global Components”. An application center is located in the STANLEY Engineered Fastening Automotive Headquarters facility in Troy, Michigan. Other sales and service office locations are in France, Germany, Italy, China, India and Japan.

A highly skilled sales and service force works directly with major customers and supports distributors in all world areas. These very experienced sales engineers and distributors are fully qualified to analyze end-user applications and propose the ideal selection of assembly tooling and support. Our customers benefit from this experience in the following ways:

- Tool and application assistance by factory trained, experienced sales and service engineers
- Field service by technicians located strategically throughout the world as well as visits from factory personnel
- Design consultation for your specific application needs, special tools, assembly machines or articulating arms

STANLEY’s Commitment to Quality

Exceed - Our Customer Expectations

Lead - Our Industry

Improve - Our Company Continuously

STANLEY Assembly Technologies utilizes the STANLEY Fulfillment System (SFS) which provides the operating methodology for delivering superior quality, value and service to our customers.

Our people, working in an environment of teamwork, combined with our manufacturing equipment, a world-class global supply chain and proven techniques produce the highest quality power tools in the world.

ISO Certification

STANLEY Assembly Technologies has successfully met the requirements of the ISO 9001 – Quality Systems international standards for quality management and quality assurance. The requirements included a review of our quality management system covering the design of our products and our processes for procurement, production, delivery and quality assurance for our Cleveland, Ohio facility.

A Quality Certified Company Since 1995.



World Wide Sales and Service Offices

Strategically located throughout the world, STANLEY Assembly Technologies is well positioned to serve you. Our global locations serve our customers through:

- Order entry and processing
- Inventory management and storage
- Technical services and support
- Sales support and advice

CE Compliance

All STANLEY Assembly Technologies' products shipped to the European Union conform to the appropriate CE directives and EC Machine Directives. All products bear the CE marking and are shipped with the operator's instructions and declaration of conformity. We maintain the required technical files and all products are tested in accordance with the EN test code standards.

World Headquarters

STANLEY Assembly Technologies

5335 Avion Park Drive
 Cleveland, Ohio 44143-2328
 USA Tel: +1.440.461.5500
 Fax: +1.440.461.5592
 Email: SATInfo@sbdinc.com

Ergonomic By Design

As a major supplier of power tools to industrial manufacturing facilities worldwide we have been involved in ergonomics since our inception in 1963. Ergonomic multi finger triggers, handle size and high power to weight ratios make our tools user friendly and preferred by operators. From the beginning our tools are designed with the operator in mind.

From patented clutch designs in our air tools to the use of patented speed control algorithms for DC Electric tools, we are continuously finding new ways to reduce the torque reaction impulse felt by the operator of our direct-drive tools.

We also offer a complete line of articulating arms and balance devices to provide alternative solutions to torque reaction strain on operators.

Our pistol style tools have been designed with an under slung handle which changes the center of balance and puts the tool weight directly over the hand. This allows the operator to hold the tool level without having to pull then hold the tool to the level position required with other handle in the rear tool designs.

The safe use of our products is paramount to our company which has lead to our working with national and international organizations to actively participate in the development of noise and vibration standards. Our tools have very low noise and vibration levels as a result of this participation.

While we must design tools for safe and convenient operation, the primary ergonomic concern is in the operator station design. The position of the operator, the position of the hand or arm, body attitude and reach while applying the tool are of critical importance. We can help mitigate ergonomic stresses by recommending the best tool geometry, reaction device and operator position to fit the application. You can rely on our expertise to recommend a safe working process while setting high integrity joints with ergonomically designed tools.

Contact your STANLEY Sales Engineer or our website to obtain a copy of our Preventive Maintenance Guidelines covering proper inspection, repair and testing of all STANLEY power tools.

Preventive Maintenance

To ensure years of trouble free operation we recommend establishing a program of inspection, maintenance and calibration of our power tools at regularly scheduled intervals.

Preventive maintenance, making repairs and replacing worn parts periodically before they become so worn and cause extensive damage can lower maintenance costs considerably and prevent loss of production.

Repair Service

STANLEY Assembly Technologies strives to build tools that will remain “on the job” for years. We use the highest grade material available in our products to maintain durability and resist wear. Mechanical and electrical components do wear out despite this high engineering effort. That is why we maintain a stock of repair parts for all of our power tools. We certify repair centers around the world annually, to provide the best technical service and fast as possible repair turn around with genuine STANLEY parts. STANLEY Certified Repair Centers are capable of the same level of repair and test as our factory.

Contact your STANLEY Sales Engineer or our website for a complete list of Certified Repair Centers around the world.

Recalibrating Tools

Instrumented power tools require periodic verification of their dynamic torque output by calibration of the torque sensing transducer. Our factory and our Certified Repair Centers maintain the capability to recalibrate any power tool using the latest electronic torque measuring equipment. A calibration certificate is supplied with each tool calibration performed.

Training

STANLEY provides training at their facility in Troy, Michigan on a quarterly basis. Local sessions can also be arranged upon request. Topics include Torque Theory, Tool Design and Operation, Controller Features and Benefits, Programming and Setup, Plant Integration, Networking, Data Collection and Troubleshooting of Faulted Joints. We encourage attendance in at least one of these training sessions to become more familiar with fastening in general and STANLEY’s products specifically.

Technical Support

As a supplier to the assembly market, STANLEY has developed a global service network to support the manufacturing operations of our customers. STANLEY offers many levels of customer support from basic maintenance and operator training to full service repair facilities and maintenance service contracts.

Partnering

STANLEY Assembly Technologies has always believed that the relationship with our customers should be defined as a “partnership” not just a generic vendor/ buyer relationship. This partnership is based on:

- **Understanding customer fastening needs.**
- **Prompt and diligent resolution of issues.**
- **Our goal of being the first choice for your threaded fastening needs**

As a partner we strive to provide improved fastening solutions that result in the ability to increase productivity while reducing warranty and total per unit fastening costs. STANLEY’s superior solutions are designed to not only meet, but exceed customer expectations.

Tool Speeds

Tool speeds are indicated in revolutions per minute or “rpm” and indicates the free speed or the speed at which the tool runs at no load. Pneumatic tool speeds are rated at a working pressure of 6.3 bar, or 90psi if not stated otherwise and can deviate up to +/- 10% from the stated value. Electric tool speeds are the rated (maximum) speed of the tool. Variable speeds lower than rated are available through the programming interface.

Tool Weights

Tool weights are published in both Kilograms (kg) and Pounds (lb). All tool weights are approximate and some slight variations from engineering changes are possible.

Tool Configuration

To configure a specific tool see the options that go along with the tool type, style and torque range listed. Simply add the option part number to the end of the tool model number when ordering to receive the option requested installed and ready for service. For angle head options, find the appropriate configurable option needed in the matrix listing for the angle head. For pricing and lead time of options contact your local STANLEY Assembly Technologies sales professional.

For Example, EB33LA18-48 with Rubber Grip and 360° Swivel Bail would be:

Individual part Numbers:

Tool Order Number: EB33LA18-48

Grip Order Number: 20H207910

Bail Order Number: 20K101400

When placing the order for this configuration of tool, the part number would then be the following:

Qty	Order Number	Including
1	EB33LA18-48	20H207910, 20K101400

Note: Options may be ordered separately and installed later. To place orders for items that will not be factory installed simply list the item numbers as separate lines. When ordering configurable options for a tool the lead-time for the tool then becomes that of the longest item added to the tool. Please contact a STANLEY Assembly Technologies sales professional for lead times and delivery.

*You can find available
Controllers on page
14 - 24 and Cables on
pages 90 and 91.*

All of the STANLEY Assembly Technologies' tools use a common lettering/ numbering structure that will guide the user through the process of choosing the correct tool in the correct form for use. There are three separate lines of tools presented in the catalog and a clear method of naming and understanding has been implemented for ease of use.

The tool key to the right explains the significance of the letters/ numbers forming the name of the tool model and part number.

DC Electric Tools

E B 3 3 L A 18 - 46

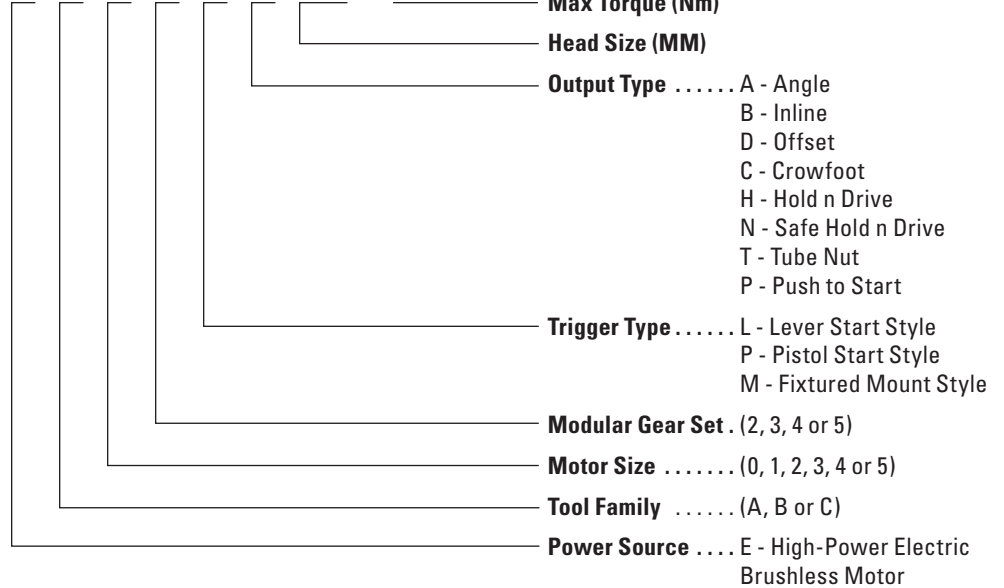

Air Clutch Tools

A A 3 3 L A 18 - 46

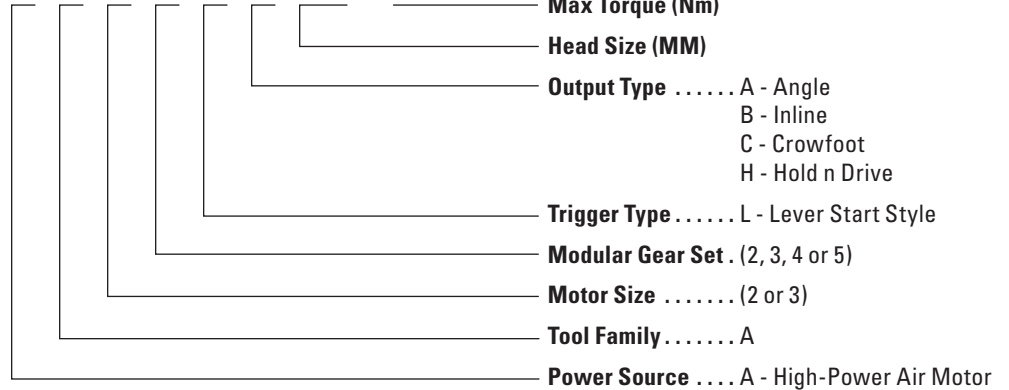

Pulse and Impact Tools

A H 3 0 P B M A - 46

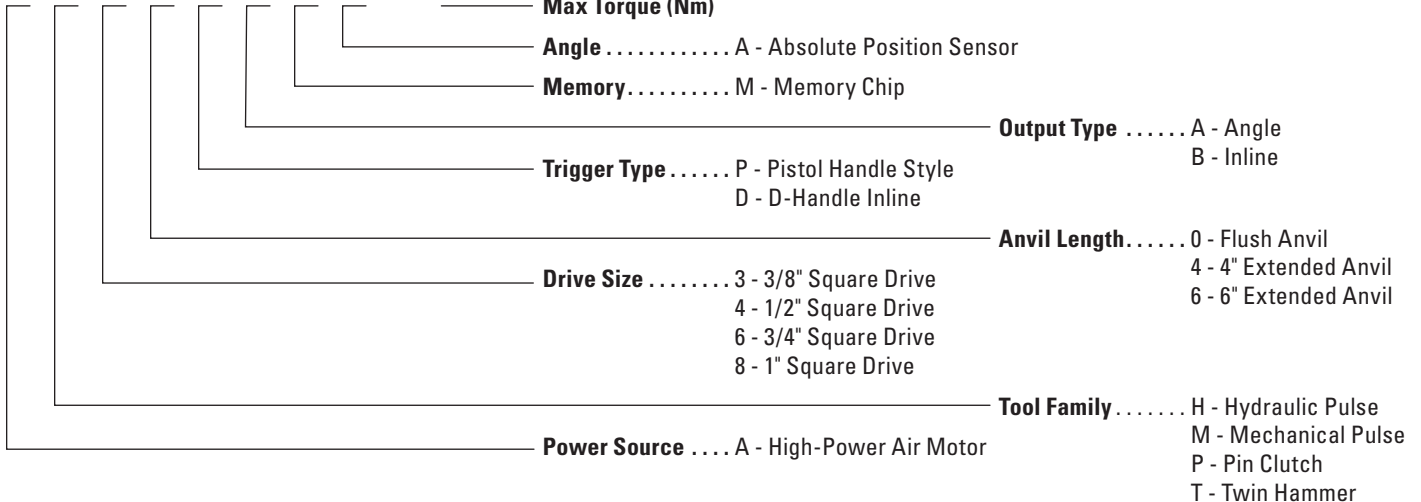

Assembly tool selection considers the power source, control method, tool geometry and torque level. STANLEY Assembly Technologies can tailor these parameters to fit each threaded fastening application.

Power Sources: Electric vs. Pneumatic

Electric: STANLEY brushless DC electric motors offer the highest level of control, working cleaner, quieter and more efficient than pneumatic tools. STANLEY brushless DC electric motors use rare earth magnets and resolver based commutation for high efficiency and reliability. Microprocessor control adjusts torque, speed, and acceleration independently in either forward or reverse directions. DC electric control offers useful fastening strategies that incorporate patented speed control algorithms that sense the torque rate of the joint and, when necessary, automatically reduce the motor speed to minimize torque overshoot. DC electric tools require the least amount of maintenance of any type of power tool which reduces the total cost over the life of the tool.

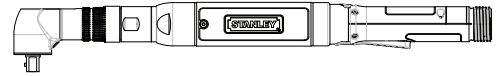

Pneumatic: Pneumatic tools use the compressed air systems available in most assembly plants. They offer excellent power to weight ratios and are usually the most economical choice for many fastening applications. STANLEY's pneumatic motors have a low inertia, locked rotor design that uses low friction materials which provides for a more efficient design with higher speeds. Pneumatic motors are easily maintained to give many years of reliable performance.

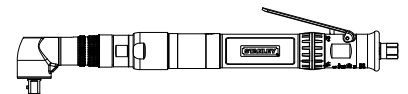

Control Methods

The control method should match the joint specifications and the quality assurance required. For the most critical applications, microprocessor based controllers can perform 100% inspection of the dynamic applied torque and collect statistical process control data. Such methods can eliminate the need for secondary inspection processes. When control requirements are less demanding STANLEY also offers more economical ways to control torque to the required specifications.

Electronically Controlled Shut Off: Available for both electric and pneumatic tools, electronic control uses a torque transducer in the tool connected to a microprocessor based controller. The controller monitors the dynamic fastening torque and shuts off the tool when the torque reaches the preset value. This closed loop control method precisely controls dynamic torque.

Electronic Monitoring: Tools without electronic shut off capability may be monitored by monitoring the dynamically applied torque process. A microprocessor based monitor observes the compressed air signature for each fastener for 100% inspection. Similar to electronic shut off tools, electronically monitored tools typically include indicator lights to alert the operator to Pass/ Fail status.

Control Methods *continued*

Clutch Actuated Shut Off: Clutch actuated shut off tools use a fast acting torque sensing clutch to disengage the motor from the drive spindle at a preset torque level. The system also shuts off the power to the motor. This fast shut off reduces the effect of operator technique on the applied torque value and the torque reaction impulse felt by the operator. Clutch actuated shut off tools reduce torque variability as compared to standard pneumatic tools. The low torque reaction impulse makes clutch actuated shut off tools ideal for hand held applications. Torque is adjusted at the tool and is not affected by variations in the supply air pressure.

STANLEY's exclusive rolling element clutch eliminates the frictional elements commonly found in competitive tools. This allows extremely close torque control without the need for repeated torque adjustment with clutch wear.

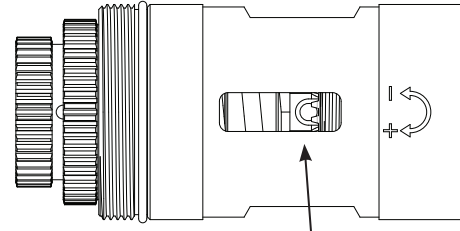

Torque Adjuster

Convenient clutch adjuster is always accessible

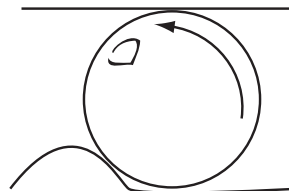

Unique Clutch Rolling Action

Durable rolling element reduces the need for torque adjustment

Tool Geometry

STANLEY offers a wide choice of pneumatic and electric tool configurations to allow the process engineer to select a tool that best suits the application. There are two primary tool classes into which tool configurations fit:

Hand Held: Applications which require an operator to maneuver the tool to the fastener and manipulate it throughout the assembly process require hand held tools. Hand held tools are available configured as any of the tools listed in the configuration section that follows. The proper selection of these tools involves a thorough understanding of the required task and a working knowledge of the resulting torque reaction and the human factors involved in the performance of the task. Every effort has been taken in the design of these tools to make them as user friendly as possible considering the work they must perform. The most critical step is in the selection process as operator safety should always be given the highest priority.

Fixtured: Fixtured nutrunners typically mount to semi automatic equipment for manipulation during single or multi-tool assembly operations. Multiple spindle fixtured tools allow the simultaneous assembly of multiple fasteners. Output configurations are Right Angle, Inline, and Offset. Offset spindle heads allow for simultaneous fastening on closer center distance. All these configurations are available with retractable spindle outputs. Nutrunners with reaction bars can mount on articulating arms or torque reaction balancers. These devices absorb torque reaction forces and help the operator to position the tool. Many hand held tools use mounting hardware for fixtured applications. Other assembly motors have mounting flanges for fixturing.



Tool Geometry - Configurations

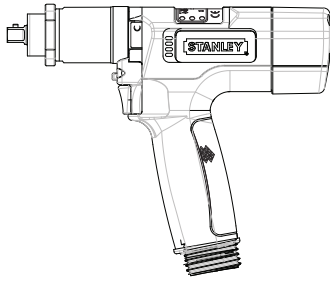

Pistol Grip (1 to 670 Nm Capacity - 1/4" to 1/2" Drive Size):

Pistol grip tools are commonly used for hand held, low torque screw driving applications as well as higher torque fixtured or hand held applications where a reaction device can be used to absorb the torque reaction forces. Care should be taken to assure that the operator's wrist is not strained during the use of these tools. Special tools can go up to 1200 Nm.

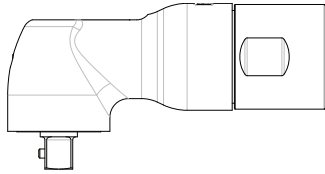

Angle Nutrunners (1 to 400 Nm Capacity - 1/4" to 3/4" Drive Size):

Angle nutrunners are well suited for many assembly applications. The minimal dimensions of our angle heads allow them to reach into restricted places, while their longer effective length reduces the torque reaction forces on the handle. For higher torque applications, these tools can be fitted with torque reaction devices. STANLEY offers a broad line of air and electric angle nutrunners with a variety of control methods.

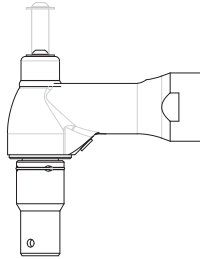

Hold and Drive (15 to 380 Nm Capacity):

Hold and drive tools simultaneously hold the bolt while the nut is tightened. A formed end on the bolt interfaces with a mating tang or bit, to prevent bolt rotation while the associated nut is tightened.

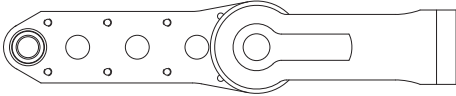

Crowfoot Nutrunners (Standard Tools - 1 to 216 Nm Capacity Special Tools to 1500 Nm- 4 to 40mm Hex Socket):

Crowfoot nutrunners use special tool geometries to access hard to reach applications where more conventional tools won't fit. Gear driven heads provide high levels of torque control. Special head designs can solve most demanding assembly problems.

Tool Geometry *continued*

Tube Nut Runners (1 to 100 Nm Capacity - 8 to 32mm Hex Socket):

Tube nut runners typically fasten the compression fittings on fluid lines. They can also fasten cable assemblies and tie rod adjustment applications. After tightening the tool returns the socket to the home open position for removal of the tool.

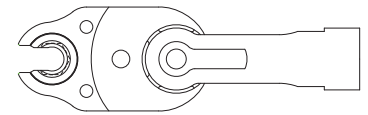

Inline (1 to 2000 Nm Capacity - 1/4" to 1" Drive Size):

Straight tools are suitable for screw driving applications where the applied torque is relatively low. They are also useful in higher torque applications when the tool is fixtured to absorb the torque reaction or equipped with a torque reaction bar. The reaction bar is placed against a solid support to absorb the torque reaction impulse.

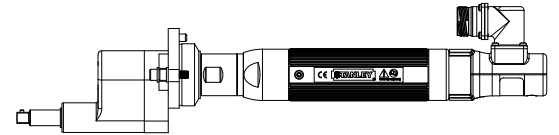

Torque Level

Once the power source, the control method and the tool configuration have been considered, the torque level must also be considered before selecting the exact tool model. STANLEY offers a wide selection of torque ranges for each specific type of tool listed. The rated torque values shown represent the highest torque level that can be expected from that model. Torque can always be adjusted down, but never above the rated value. A general rule of thumb is that most air tools can be reasonably adjusted to 50% of their rated torque. If the application requires the torque to be adjusted significantly below the rated value, it is often better to choose the next lower rated tool as generally this will provide a faster tool.

Torque Defined — The Anatomy of a Threaded Joint

When we assemble a threaded joint, we rotate the fastener by applying Torque (in this example we hold the bolt and rotate the nut). The thread pitch causes this rotation to advance the nut and stretch the bolt.

What Holds a Joint Together?

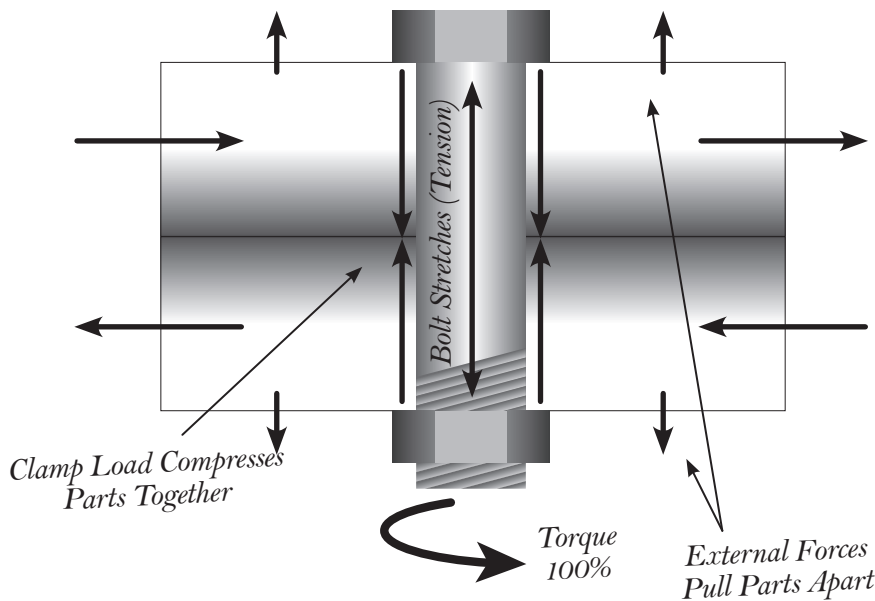

This produces tension within the bolt just as if it were a large spring. This Tension in the bolt produces the Clamp Load that holds the assembled parts together. And this clamp load must be sufficient enough to resist all the external forces that can be applied to this assembly throughout its service life.

The bolt acts like a very stiff spring. The more Clamp Force the bolt applies, the more service loads the joint can resist without coming apart. Of course, the bolt must be selected to have sufficient strength to resist the expected external loads. The bolt must also be assembled so that it holds the parts together when the external loads attempt to pull it apart.

The process of tightening a fastener is sometimes called “pre-loading” the fastener. This creates tensile load in the bolt, which “pre-loads” the joint to counteract the expected service loads.

Where does it all go?

The 50-40-10 Rule

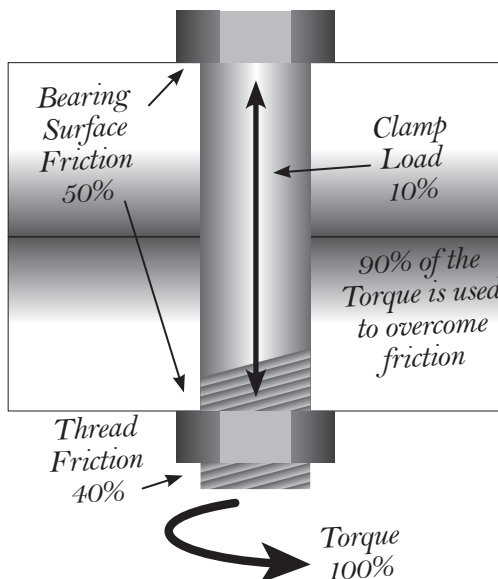

When we apply a certain amount of torque to a fastener, fifty percent of that torque is used to overcome the friction of the bearing surface (under the nut, or under the bolt head, depending on which is being rotated). Forty percent of the applied torque is used to overcome the friction in the threads. With only ten percent of the applied torque actually used to stretch the fastener.

As we saw earlier, it is the stretch of the fastener that produces the clamping force that actually holds the assembled parts together. This is called the “50-40-10 Rule” and it demonstrates how much influence friction can have on the results. To ensure the best possible joint you should be as diligent as possible in maintaining consistent friction characteristics of the joint.

Tightening Accuracy

The primary driver for delivering even clamp load to an application over many joints of the same design is consistent friction and consistent applied torque. Inconsistent application of torque from one joint type to another can affect the applied clamp load.

There are usually two types of joints; hard and soft. A hard joint is defined as reaching full torque via a tightening angle of roughly 30° after the bolt, or nut, has reached snug level. Snug is usually defined as 10% of the final torque value. In a soft joint, the bolt or nut sometimes has to be tightened more than two complete turns, or over 720° before the full torque is reached.

Assembly tools often give different torque values on hard and soft joints when set to the same torque target. Inertial effects and the ability of the tool to stop movement and applying torque quickly cause this difference. The difference in torque values is generally known as mean shift. Lowering the effect of mean shift increases the possibility of consistent clamp load and is achieved through precision design and patented ATC software available on all electric tooling from Stanley. **For more information on mean shift and accuracy, see ISO-5393 or contact your local Stanley sales professional.**

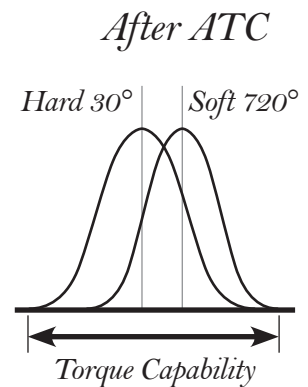
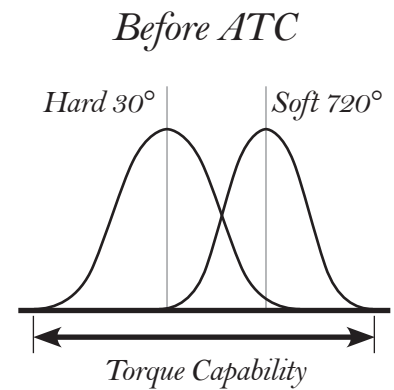

Improved Capability and Reduced Cycle Time

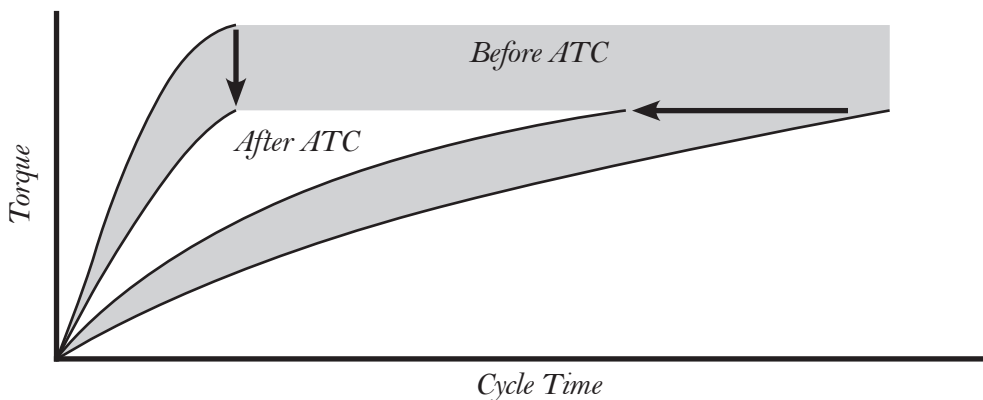



QB Controllers

Single Spindle Controller for Fixtured, Handheld, or Cordless Tools

This new generation of QPM controllers has been completely redesigned to provide more, and easier, connectivity and to power the higher power density EB tools, the older E and EA, EC tools and the QPM Cordless tools.

Five of the QB Alpha controllers operate any EA, EB or EC QPM tool up to 2000 Nm as a stand alone controller. Four of the controllers operate the E tools. Two controllers are 802.11b/g/n to manage the QPM Cordless tools.

Basic, Standard, Advanced and Expert controllers can be setup from the front panel or from a computer's web browser using the Alpha Toolbox @tb Ethernet connection. The node requires a connection to a computer's browser or an Advanced or Expert controller for setup.

Alpha Toolbox, included in every QB Alpha, is used to program strategies, collect fastening cycle and trace data, and perform online diagnostics of the tool and controller.

QB Alpha controllers include a dedicated Alpha Toolbox @tb port, ATC, Assignable 24V DC I/O, a 24V DC mating connector, plinth and a power cord. The Basic and Standard have the typical Polychrome LCD display while the Advanced and Expert have larger color displays with the Expert having the added feature of a touch screen.

All controllers have an Ingress Protection rating of 54 (IP 54).

Onboard Diagnostics and their screens provide all the data required for hardware, software and fastening cycle analysis.

From Basic to Expert to Network Node

The Wizard provides an Easy Method to control programming directly from the keypad on the controller or with Alpha Toolbox. Users can also take advantage of advanced programming using Alpha Toolbox or Alpha Gateway software with a computer.

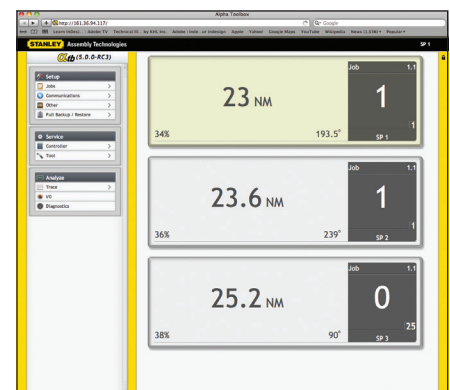

Alpha Toolbox

Specifications for All Alpha Controllers:

Dimensions: 15w x 36h x 26d cm

6w x 14h x 10d in

Weight: 7.6 kg (16.7 lb)n

I/O Power Supply: 24V DC, 1A Internal

Ready for External Power Supply

AC Power Source: Auto Detect

100 - 126.5V or 200 - 253V AC,

50 or 60 Hz

Humidity: 0 to 95 % non-condensing

Temperature: 32-122 °F (0-50 °C)

Step 1: Refer to the Model Number matrix on the specific controller page to determine the Order Number based on the options required.

Step 2: Select a power cord by the supply voltage and country.

Power Cord Description	Part No.
Argentina Power Cord 230V, 2m	20C105202
Australia Power Cord 230V, 2m	20C102103
Brazil Power Cord 230V, 2m	21C102104
China Power Cord 230V, 2m	21C103905
Euro Power Cord 230V, 2m	20C102102
Japan Power Cord 125V, 2m	20C102101
Japan Power Cord 250V, 2m	20C102105
US Power Cord 115V, 2m	20C102002
US Power Cord 115V, 7m	20C102007
US Power Cord 230V, 2m	21C103902

Power Cord Description	Part No.
UK Power Cord 230V, 2m	20C102202
Power Distribution Panel Cord, 1m	20C203401
Power Distribution Panel Cord, 2m	20C203402
Twist Lock Power Cord 115V, 2m	20C103802
Twist Lock Power Cord 115V, 4m	20C103804
Twist Lock Power Cord 115V, 7m	20C103807
Twist Lock Power Cord 230V, 2m	20C106302
Twist Lock Power Cord 230V, 7m	20C106307
GFI 30ma 250V Assembly for Europe	21E102300

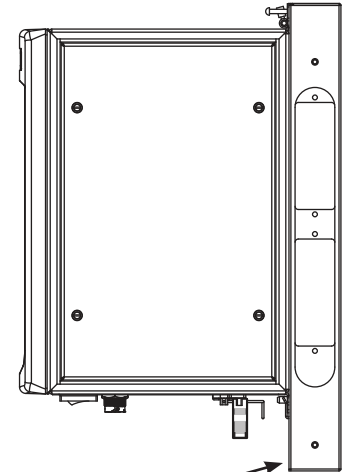

Step 3: Select I/O Cable options if required.

I/O Mating Connector Description	Standard/Optional	Part No.
24V I/O Mating Connector, Phoenix for Basic Alpha	Standard	21C104806
24V I/O Mating Connector, Solder Cup (Standard, Advanced, Expert, Network Node)	Standard	21C104800
24V I/O Mating Connector, Crimp Pins (Standard, Advanced, Expert, Network Node)	Optional	21C104802
24V I/O Mating Connector, Crimp Pins, with Crimp Tool (Standard, Advanced, Expert, Network Node)	Optional	21C104804
5M, 24V I/O Ext. Cable (I/O Connector to Pigtail)	Optional	21C202005
20M, 24V I/O Ext. Cable (I/O Connector to Pigtail)	Optional	21C202010
10M, 24V I/O Ext. Cable (I/O Connector to Pigtail)	Optional	21C202020
I/O Bracket Assembly, 19-Pin to Phoenix	Optional	21E102202

Plinth

- Quick-change mounting by hand
- Cable management and routing

Floor Stand

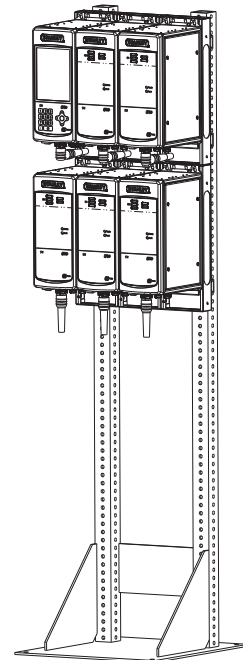

Top row of controllers require a 90° Extension. See Cable Options

Step 4: Select a Floor Stand if required.

Floor Stand Description	No. of Spindles	Dimensions	Part No.
Floor Stand Kit	1 to 6	198H x 61W x 56D cm	21F100404
Assembled System with Floor Stand	1 to 6	78H x 24W x 22D in	Add /F to Model No.
Floor Stand Kit	7 to 12	198H x 61W x 88D cm	21F100402
Assembled System with Floor Stand	7 to 12	78H x 24W x 34.5D in	Add /F to Model No.

QB Basic Single Spindle Controller



The Basic Alpha controller operates as a stand alone controller. Basic controllers are setup from the front panel on the controller or from a computer web browser using the *Atb* serial port. Alpha Gateway computer software is used to program strategies, collect fastening cycle and trace data, and perform online diagnostics of the tool and controller. The software can be used offline to program, or edit, strategies and analyze data retrieved from any QB controller.

Controls Assembly Process, Data and I/O

- Typical LCD Display
- 2 Jobs and 2 Tasks with 2 Steps
- Torque Control/Angle Monitoring Strategy with SmartSteps
- Angle Control/Torque Monitoring Strategy with SmartSteps
- Stores Fastening Cycle Data for 500 Fastening Cycles such as Torque, Angle, Date, Time
- Stores Trace Data for 1 Fastening Cycles
- Real Time Statistics include Cpk, Cpk, Pp, Ppk, CAM, Mean, Deviation, and more
- Alpha Toolbox *Atb* Serial Port
- 24V DC I/O, 4 Inputs / 4 Outputs, assignable
- Enclosure has an IP 54 rating with excellent protection against dust and moisture.

Alpha Model Number	Serial	Ethernet	USB	24V DC I/O	Modbus/TCP	Alpha Toolbox
QB1001				✓		✓

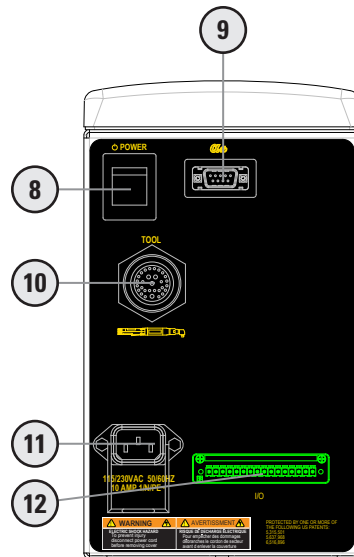
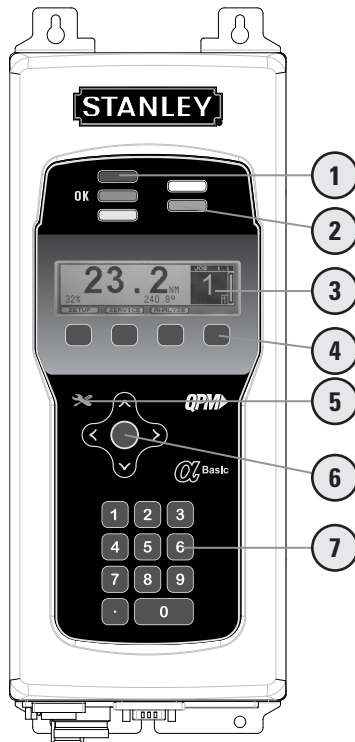

Description	
1	Red, Green, Yellow LEDs for Limits Evaluation
2	Programmable and Tool Ready LEDs
3	Display
4	Function Keys with Active Label Above
5	Maintenance Due Indicator
6	Cursor Keys with Center Button to Expand Lists
7	Numeric Keypad to Enter Numbers or Select Options
8	Power Switch
9	Alpha Toolbox Connector
10	Tool Connector
11	Power Input
12	24V DC Input/Output Connector

The Standard Alpha controller operates as a stand alone controller. Standard controllers are setup from the front panel on the controller or from a computer web browser using the *Atb* Ethernet port.



Alpha Toolbox, included in every Standard controller, is used to program strategies, collect fastening cycle and trace data, and perform online diagnostics of the tool and controller. Simply connect a computer to the *Atb* Ethernet port, type "ATB.QPM" into a web browser and the Standard will present the intuitive software for use.

Standard controllers include a USB port, a Serial port and Alpha Toolbox software.

Controls Assembly Process, Data and I/O

- Typical LCD Display
- 16 Jobs and 16 Tasks with 8 Steps
- Torque Control/Angle Monitoring Strategy with SmartSteps
- Angle Control/Torque Monitoring Strategy with SmartSteps
- Stores Data for 1,000 Fastening Cycles and Traces
- Real Time Statistics include Cpk, Cpk, Pp, Ppk, CAM, Mean, Deviation, and more
- USB port for Data / Parameter Values Import / Export to USB Memory Stick
- Alpha Toolbox *Atb* Ethernet Port
- DB-9 RS-232 (Serial) Port for barcode or print functions
- 24V DC I/O, 8 Inputs / 8 Outputs, assignable
- Enclosure has an IP 54 rating with excellent protection against dust and moisture.



Alpha Model Number	Serial	Ethernet	USB	24V DC I/O	Modbus/TCP	Alpha Toolbox
QB2001	✓		✓	✓		✓
QB2101	✓		✓	✓		✓

QB2101 is compatible with E series tools.

Description
1 Red, Green, Yellow LEDs for Limits Evaluation
2 Programmable and Tool Ready LEDs
3 Display
4 Function Keys with Active Label Above
5 Maintenance Due Indicator
6 Cursor Keys with Center Button to Expand Lists
7 Numeric Keypad to Enter Numbers or Select Options
8 Power Switch
9 Alpha Toolbox Connector
10 USB Port for Data Transfer
11 Tool Connector
12 24V DC Input/Output Connector
13 Serial Port Connector
14 Power Input

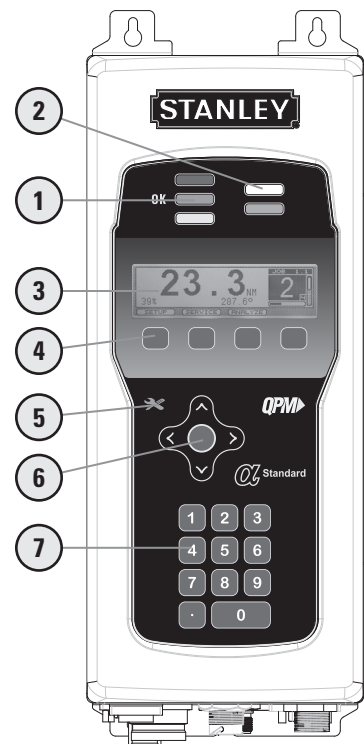
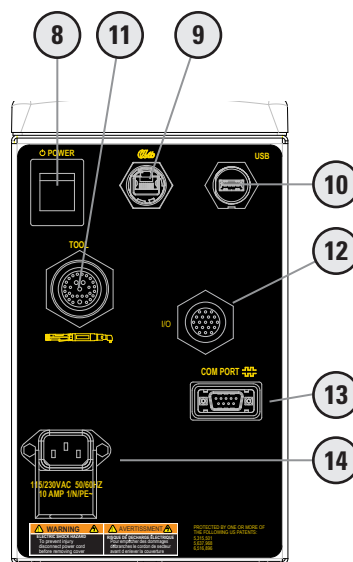

QB Advanced Single Spindle Controller



The Advanced Alpha controller operates as a stand alone controller or as part of a multiple (fixtured) system. The Advanced controller can control up to 2 spindles including its own. Node Alphas are typically used for the trailing tool, but another Advanced could also be used.

The integrated PLC provides flexibility to help integrate the Advanced into a facility's control scheme. Use the PLC Editor in Alpha Toolbox to create a PLC program.

Advanced controllers are setup from the front panel on the controller or from a computer web browser using the *atb* Ethernet port. Alpha Toolbox, included in every Advanced controller, is used to program strategies, collect fastening cycle and trace data, and perform online diagnostics of the tool and controller. Simply connect a computer to the atb port, type "ATB.QPM" into a web browser and the Advanced will present the intuitive software for use.

Advanced controllers include a USB port, a set of switched Ethernet ports, a Serial port, fieldbus options and Alpha Toolbox software.

Controls Assembly Process, Data and I/O

- Larger Sized Color Display
- 255 Jobs and 99 Tasks with 12 Steps
- All Fastening Strategies including Yield and Rate Control and Torque Averaging
- Stores Fastening Cycle Data for 30,000 Fastening Cycles such as Torque, Angle, Date, Time, VIN#
- Stores Trace Data for 10,000 Fastening Cycles
- Real Time Statistics include Cpk, Cpk, Pp, Ppk, CAM, Mean, Deviation, and more
- USB port for Data / Parameter Values Import / Export to USB Memory Stick
- RJ-45, 10/100BaseT Ethernet Port for the Ultimate in Connectivity
- DB-9 RS-232 (Serial) Port for barcode, print or network functions
- Internal PLC for Advanced User-Specific Functionality
- Fieldbus options for the perfect connection the to facility
- Lead Controller for Dual-Spindle Mode
- Can be used as trailing spindles in Multiple-Tool (Fixtured) Applications
- 24V DC I/O, 8 Inputs / 8 Outputs, assignable
- Enclosure has an IP 54 rating with excellent protection against dust and moisture.

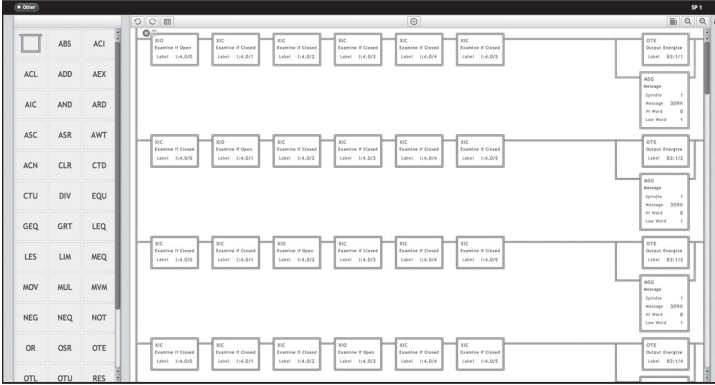

Alpha Toolbox now comes with a PLC Editor

Standard Features

All Models	Serial	Ethernet	USB	24V DC I/O	Modbus/TCP	Alpha Toolbox
	✓	✓	✓	✓	✓	✓

Alpha Model Number for Optional Features

	DeviceNet	PROFIBUS	EtherNet/IP	PROFINET	GM Ports	Lead	Devicenet Available
QB3001-XXV						✓	-MXV
QB3001-XDV	✓					✓	-MDV
QB3001-XPV		✓				✓	-MPV
QB3001-XEV			✓			✓	-MEV
QB3001-XNV				✓		✓	-MNV
QB3001-XGV					✓	✓	-MGV
QB3101-XXV						✓	-MXV
QB3101-XDV	✓					✓	-MDV
QB3101-XPV		✓				✓	-MPV
QB3101-XEV			✓			✓	-MEV
QB3101-XNV				✓		✓	-MNV
QB3101-XGV					✓	✓	-MGV



Dual Spindle Operation

QB3101 is compatible with E series tools.

Description
1 Red, Green, Yellow LEDs for Limits Evaluation
2 Programmable and Tool Ready LEDs
3 Display
4 Function Keys with Active Label Above
5 Maintenance Due Indicator
6 Numeric Keypad to Enter Numbers or Select Options
7 Cursor Keys with Center Button to Expand Lists
8 Power Switch
9 Alpha Toolbox Connector
10 USB Port for Data Transfer
11 Tool Connector
12 Plant / Spindle Network Ethernet Connectors
13 24V DC Input/Output Connector
14 Optional Master DeviceNet Connector
15 Serial Port Connector
16 Power Input
17 Optional Fieldbus Connector(s)

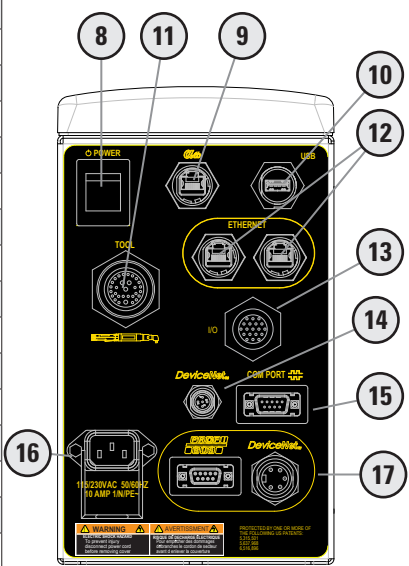

QB Expert Multiple Spindle Controller



The Expert Alpha controller operates as a stand alone controller or as the lead controller as part of a multiple (fixtured) system. The Expert controller can control up to 24 spindles including its own. Node Alphas are typically used for the trailing tools, but Advanced Alphas could also be used.



The Expert Alpha controller is also an 802.11 b/g/n wireless access point so that the QPM Cordless tools can connect as trailing spindles. Smart phones, tablets and computers may also connect to Alpha Toolbox wirelessly.

The integrated PLC provides flexibility to help integrate the Expert into a facility's control scheme. Use the PLC Editor in Alpha Toolbox to create a program. Expert controllers are setup from the front panel on the controller or from a computer web browser using the *atb* Ethernet port.

Alpha Toolbox, included in every Expert controller, is used to program strategies, collect fastening cycle and trace data, and perform online diagnostics of the tool and controller. Simply connect a computer to the *atb* port, type "ATB.QPM" into a web browser and the Expert will present the intuitive software for use.

Expert controllers include a USB port, a plant network Ethernet port, a Spindle network Ethernet port, a Serial port, fieldbus options and Alpha Toolbox software.

Controls Assembly Process, Data and I/O

- Large TOUCHSCREEN Color Display
- 255 Jobs and 99 Tasks with 12 Steps
- All Fastening Strategies including Advanced Strategies such as Yield Control, Rate Control and Torque Averaging
- Stores Data for 30,000 Fastening Cycles such as Torque, Angle, Date, Time, VIN#
- Stores Trace Data for 10,000 Fastening Cycles
- Real Time Statistics include Cpk, Cp, Pp, Ppk, CAM, Mean, Deviation, and more
- USB port for Data / Parameter Values Import / Export to USB Memory Stick
- RJ-45, 10/100BaseT Ethernet Port for the Ultimate in Connectivity
- DB-9 RS-232 (Serial) Port
- Internal PLC for Advanced User-Specific Functionality
- Fieldbus options for the perfect connection the to facility
- Lead Controller for up to 24 Multiple (Fixtured) or QPM Cordless Tools
- 24V DC I/O, 8 Inputs / 8 Outputs, assignable
- Enclosure has an IP 54 rating with excellent protection against dust and moisture.

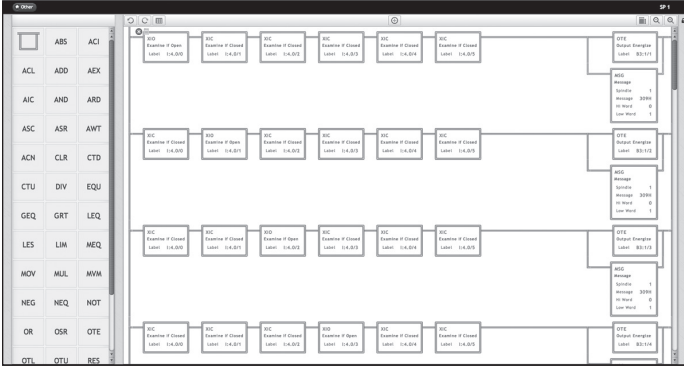

Alpha Toolbox includes a PLC Editor for easy integration of a multiple tool system.

Standard Features	Serial	Ethernet	USB	24V DC I/O	Modbus/TCP	Alpha Toolbox
All Models	✓	✓	✓	✓	✓	✓

Alpha Model Number for Optional Features	DeviceNet	PROFIBUS	EtherNet/IP	PROFINET	GM Ports	Lead	DeviceNet Available
QB4001-XXV						✓	-MXV
QB4001-XDV	✓					✓	-MDV
QB4001-XPV		✓				✓	-MPV
QB4001-XEV			✓			✓	-MEV
QB4001-XNV				✓		✓	-MNV
QB4001-XGV					✓	✓	-MGV
QB4101-XXV						✓	-MXV
QB4101-XDV	✓					✓	-MDV
QB4101-XPV		✓				✓	-MPV
QB4101-XEV			✓			✓	-MEV
QB4101-XNV				✓		✓	-MNV
QB4101-XGV					✓	✓	-MGV

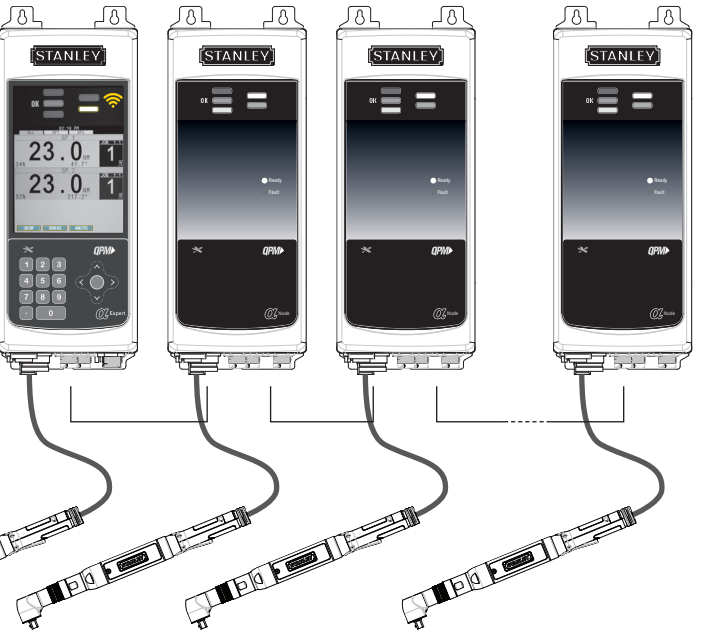

Spindles 1-24 connect using an isolated Ethernet Spindle Network

QB4101 is compatible with E series tools.

Description	
1	Red, Green, Yellow LEDs for Limits Evaluation
2	Programmable and Tool Ready LEDs
3	Display
4	Function Keys with Active Label Above
5	Maintenance Due Indicator
6	Numeric Keypad to Enter Numbers or Select Options
7	Cursor Keys with Center Button to Expand Lists
8	Power Switch
9	Alpha Toolbox Connector
10	USB Port for Data Transfer
11	Tool Connector
12	Plant Network Ethernet Connector
13	Spindle Network Ethernet Connector
14	24V DC Input/Output Connector
15	Optional Master DeviceNet Connector
16	Serial Port Connector
17	Power Input
18	Optional Fieldbus Connector(s)

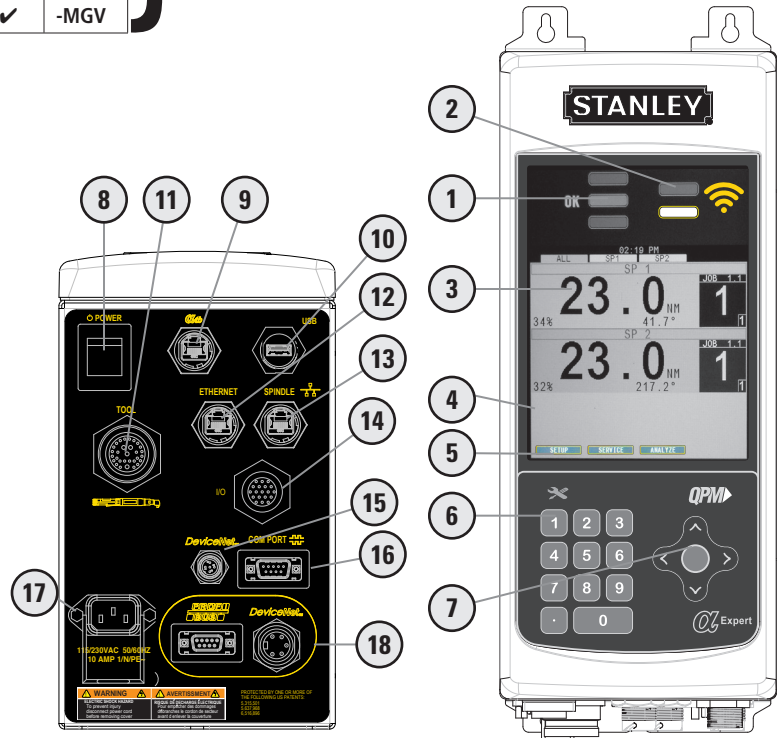

QB Node Single Spindle Controller



The Node Alpha controller operates as part of a multiple (fixtured) system. Node controllers are setup from the front panel of the Lead Expert or Advanced controller or from a computer web using the *Atb* Ethernet port.

Alpha Toolbox, included in every Node controller, is used to program strategies, collect fastening cycle and trace data, and perform online diagnostics of the tool and controller. Simply connect a computer to the *Atb* port, type "ATB.QPM" into a web browser and the Node will present the intuitive software for use.

Node controllers include a set of switched Ethernet ports, a Serial port, fieldbus options and Alpha Toolbox software.

Controls Assembly Process, Data and I/O

- 255 Jobs and 99 Tasks with 12 Steps
- All Fastening Strategies including Advanced Strategies such as Yield Control, Rate Control and Torque Averaging
- Stores Data for 30,000 Fastening Cycles such as Torque, Angle, Date, Time, VIN#
- Stores Trace Data for 10,000 Fastening Cycles
- 2 Switched RJ-45, 10/100BaseT Ethernet Port for Spindle Network Connections
- Can be used for trailing spindles in Multiple Tool (Fixtured) Applications
- Enclosure has an IP 54 rating with excellent protection against dust and moisture.

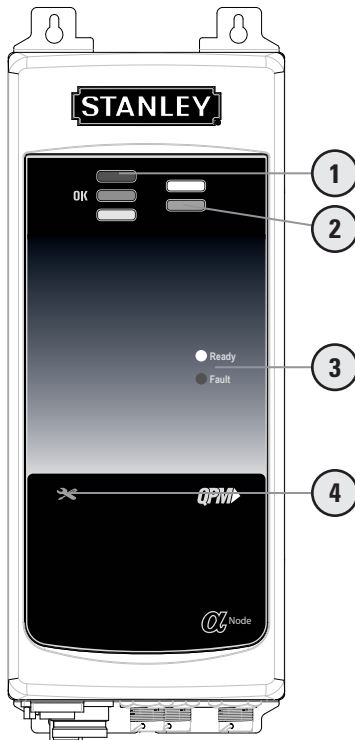

Alpha Model Number	Serial	Ethernet	USB	24V DC I/O	Modbus/TCP	Alpha Toolbox
QB0001		✓				✓
QB0101		✓				✓

QB0101 is compatible with E series tools.

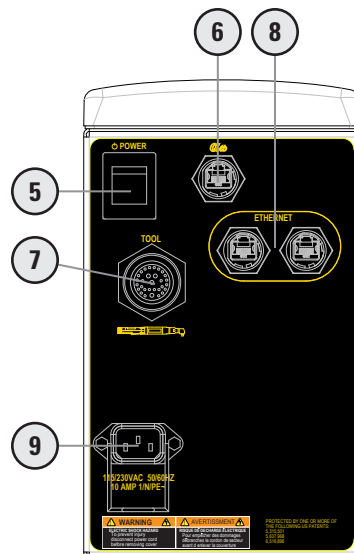

	Description
1	Red, Green, Yellow LEDs for Limits Evaluation
2	Programmable and Tool Ready LEDs
3	Ready / Fault LEDs
4	Maintenance Due Indicator
5	Power Switch
6	Alpha Toolbox Connector
7	Tool Connector
8	Spindle Network Ethernet Connectors
9	Power Input

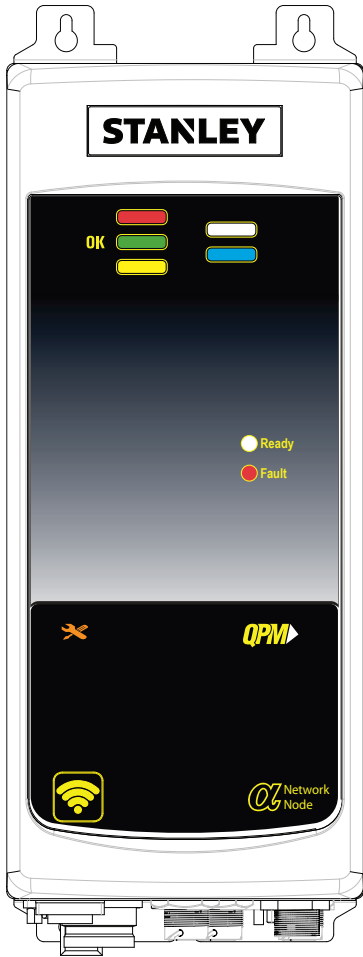

The Network Node Alpha controller was designed to be the interface between the QPM Cordless tools and customers' Error Proofing or Data Collection system. Network Node controllers are setup from a computer's web browser using the *Atb* Ethernet port.

Alpha Toolbox, included in every Network Node controller, is used to program strategies, collect fastening cycle and trace data, and perform online diagnostics of the QPM Cordless tools. Simply connect a computer to the *Atb* port, type "ATB.QPM" into a web browser and the Node will present the intuitive software for use.

Node controllers include an Ethernet port, a Serial port and Alpha Toolbox software.

Controls Assembly Process, Data and I/O

- For up to 6 QPM Cordless Tools
- TC/AM or AC/TM Fastening Strategies
- 1 RJ-45, 10/100BaseT Ethernet Port for Network connections
- DB-9 RS-232 (Serial) Port
- Internal PLC for Advanced User-Specific Functionality
- 24V DC I/O, 8 Inputs / 8 Outputs, assignable
- Enclosure has an IP 54 rating with excellent protection against dust and moisture.

Alpha Model Number	Serial	Ethernet	USB	24V DC I/O	Modbus/TCP	Alpha Toolbox
QB0201	✓	✓		✓	✓	✓ IEEE 802.11
QB0301	✓	✓		✓	✓	✓ IEEE 802.15.4

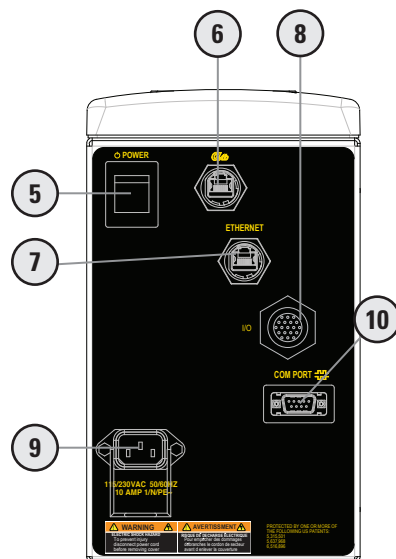
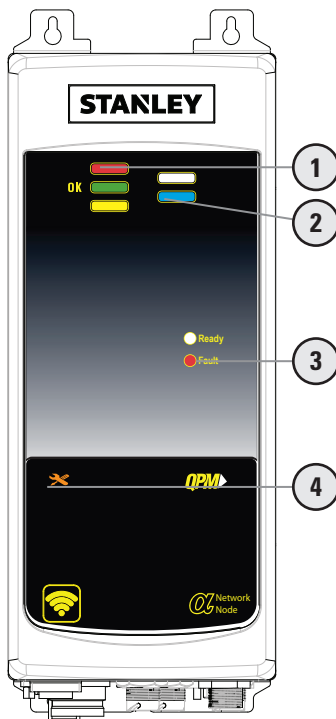

Description	
1	Red, Green, Yellow LEDs for Limits Evaluation
2	Programmable and Tool Ready LEDs
3	Ready / Fault LEDs
4	Maintenance Due Indicator
5	Power Switch
6	Alpha Toolbox Connector
7	Tool Connector
8	Spindle Network Ethernet Connectors
9	Power Input
10	Serial Port Connector

QB Spindle Disconnect Controllers

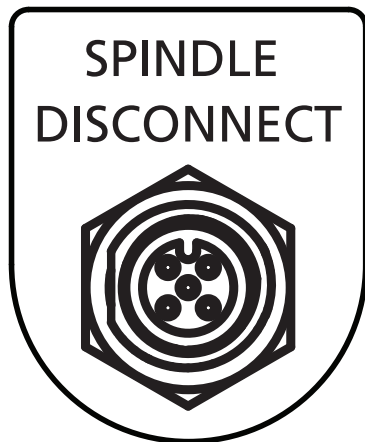

Spindle Disconnect controllers are the same as the controllers on the previous pages with the exception they have a contactor inside to disconnect the 3-phases to the motor to stop the tool when activated. These controllers are designed to operate as part of a multiple (fixtured) system.

SPINDLE DISCONNECT

Connector on Bottom of Controller

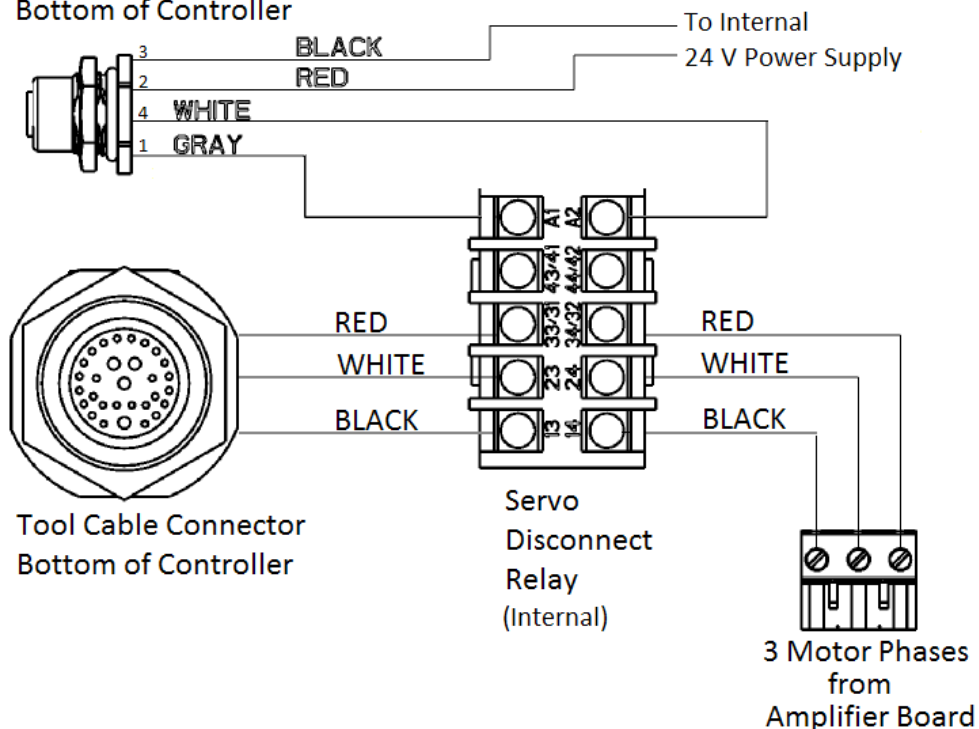

The controllers that have the Spindle Disconnect are the Expert, Advanced and Node. The model numbers will change from the previous pages. See chart.

Controller	Part No.
Node	QB0111
Advanced	QB3111-XXX
Expert	QB4111-XXX

If options for the controller are required use the extensions from the appropriate controller page to add the proper extension. For instance if Profibus is required on an Advanced controller use QB3111-XPV to get the Advanced controller with the Servo Disconnect and the Profibus fieldbus for the controller.

Accessories	Part No.
M12 Spindle Disconnect Tee	21R202205
M12 Spindle Disconnect Cable	21C102302

QPM Cordless Tools

Cordless Tools

- Pistol and Lever style
- IEEE 802.11 b/g/n wireless connection to QB Expert or Network Node controllers
- Transducerized closed loop control
- Brushless DC Motor with Programmed Speed Control
- Visual and audible operator feedback
- Stores data for the last 500 fastening cycles and one trace
- 16 jobs, 16 tasks with 2 steps, including Smart Steps.
- USB port connects to a computer for ATB functionality
- Optional Barcode Scanner
- Optional 802.15.4 Radio

Lithium Ion Battery Pack

- 20V 4 Amp hour
- Estimated 2,200 fastening cycles per charge (*depending on the joint rate*)
- Approximately 1,000 charge cycles throughout usable life.
- 3-LED Fuel Gauge system provides immediate feedback on state of charge



Battery Pack - 21R209300

Battery Pack Charger

- Charges battery pack in <1 hour
- Automatic temperature detect to protect the battery pack
- Simple operation

One Battery Pack and Charger included with tool in U.S., Canada and Mexico only



Charger - 21R209500

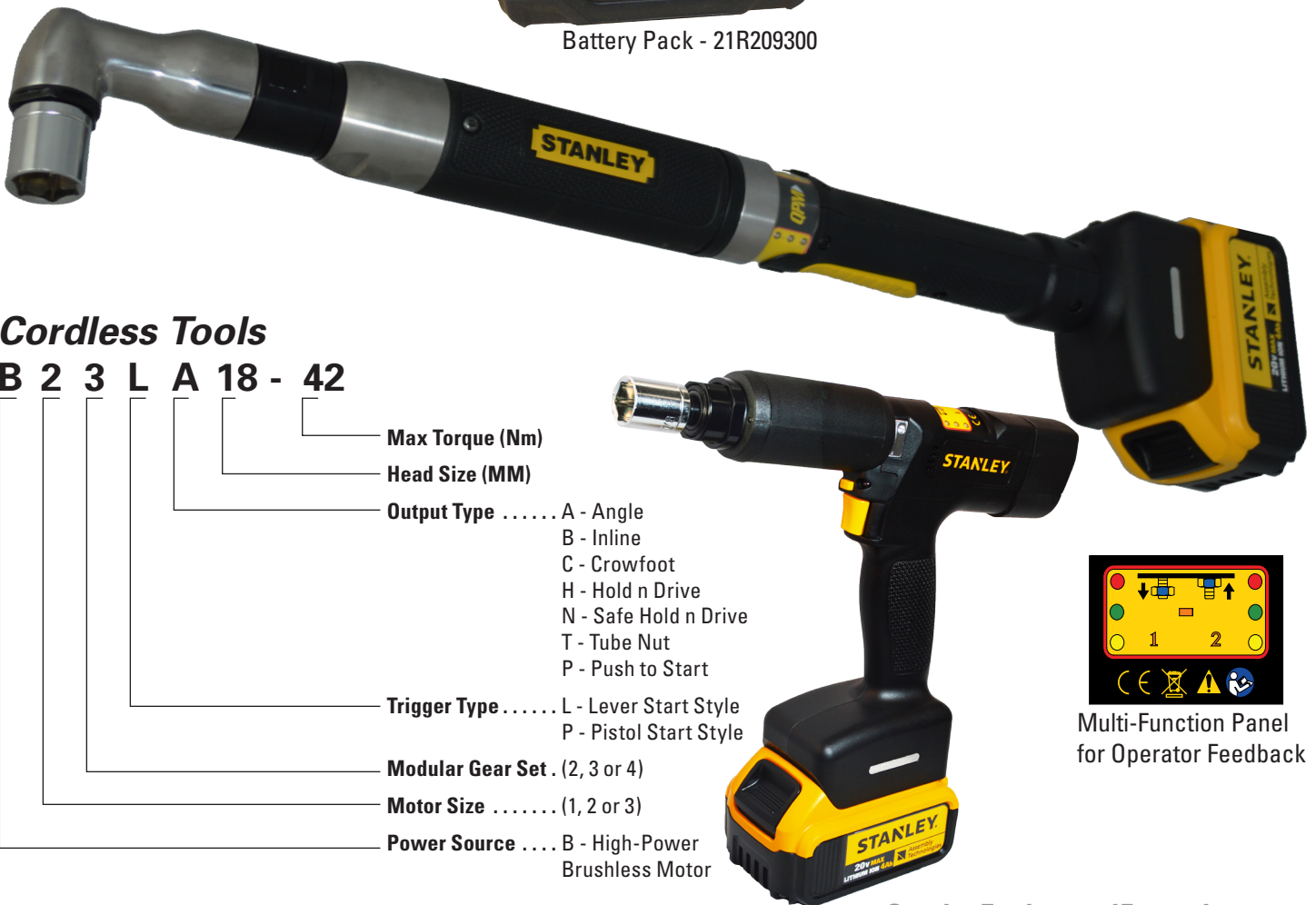

Cordless Tools

B 2 3 L A 18 - 42

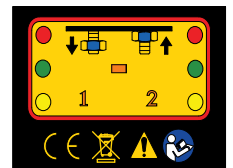
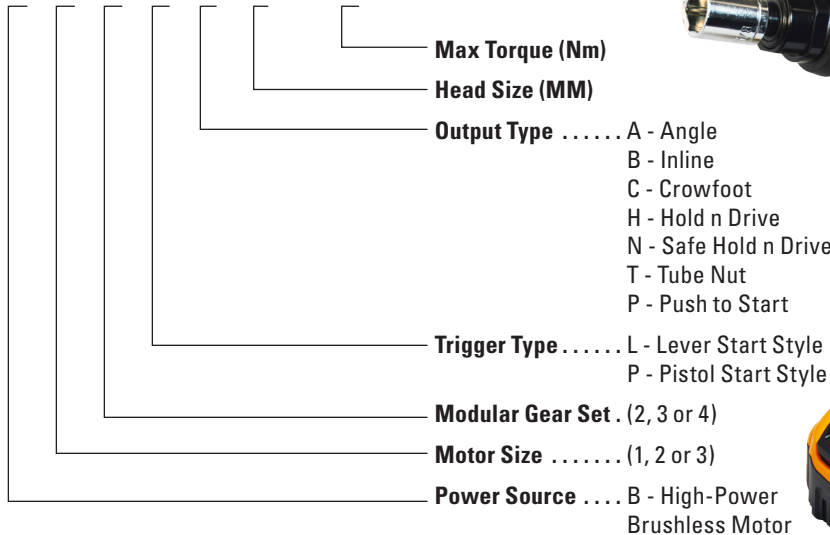

Multi-Function Panel for Operator Feedback

B Series Cordless Pistol Grip Tools

QPM Cordless Pistol Grip Tools (1.2 to 14 Nm)

Pistol Tool Options

B12 Output Options	Part No.
1/4" Square Drive	20D119302
1/4" Quick Change	20D119300
3/8" Square Drive	20D119301
Socket Lock Pin 1/4" SD	Part No.
Lock Pin Plug	A3090
Lock Pin	A3060
Spring	A3073
Socket Lock Pin 3/8" SD	Part No.
Pin Stop	L3401
Lock Pin	20D227800
Spring	20R201413
Rounded (Ball Detent)	20D227801
B12P Reaction Components	Part No.
Spacer	20D217000
Reaction Bar, Aluminum 17"	20K100103
Reaction Bar, Steel 17"	20K100104
Suspension Bail	Part No.
Wire Bail	A3061
Anti-Mar Protection	Part No.
Battery Pack Cover - 4 Ahr	20R215400
Battery Pack Cover - 2 Ahr	20R215401
Handle Options	Part No.
Barcode Scanner	20H106100
Zigbee Radio	20H106102

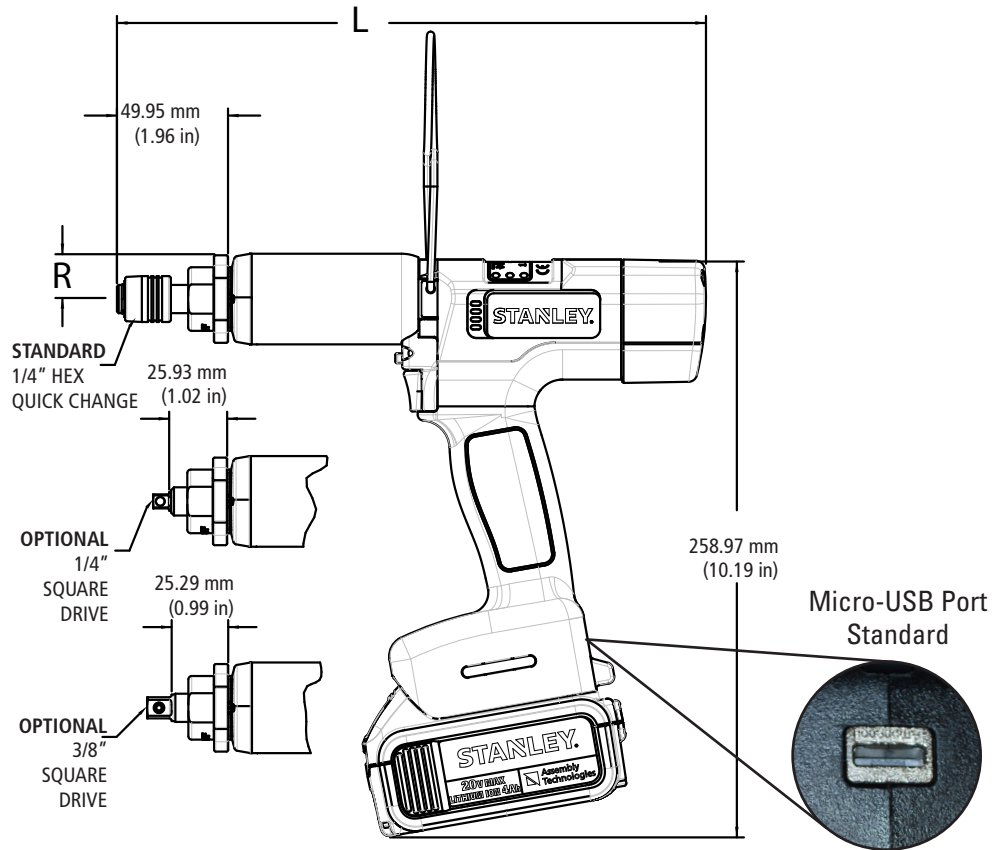

	Model	Rated Speed		Torque		"R" Side to Center		"L" Length		Weight w/ Battery		Weight w/o Battery		Output	
		RPM		Nm	lb ft	mm	in	mm	in	kg	lb	kg	lb	Standard	Options
Inline Style	B12PB-6	1290	6	4.4	20	0.8	264	10.4	1.82	4.0	1.14	2.5	1/4" QC	1/4" or 3/8" SD	
	B12PB-9	895	9	6.6	20	0.8	264	10.4	1.82	4.0	1.14	2.5	1/4" QC	1/4" or 3/8" SD	
	B12PB-14	615	14	10.3	20	0.8	264	10.4	1.82	4.0	1.14	2.5	1/4" QC	1/4" or 3/8" SD	
Push-to-Start	B12PP-6	1290	6	4.4	20	0.8	264	10.4	1.82	4.0	1.14	2.5	1/4" QC	1/4" or 3/8" SD	
	B12PP-9	895	9	6.6	20	0.8	264	10.4	1.82	4.0	1.14	2.5	1/4" QC	1/4" or 3/8" SD	
	B12PP-14	615	14	10.3	20	0.8	264	10.4	1.82	4.0	1.14	2.5	1/4" QC	1/4" or 3/8" SD	

Total vibration emission value: <2.5 m/sec² (ISO 28927-2:2009); Sound pressure level at work station LpA (ref 20µPa) is < 70dB(A) (ISO 15744-2002).

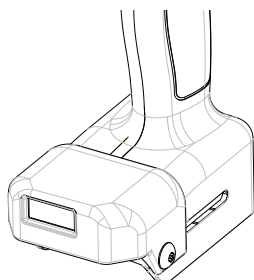

Barcode Scanner Option
Inline Tool - 20H106100
PTS Tool - 20H106101

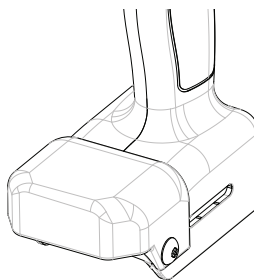

IEEE 802.15.4 Radio
Inline Tool - 20H106102
PTS Tool - 20H106103

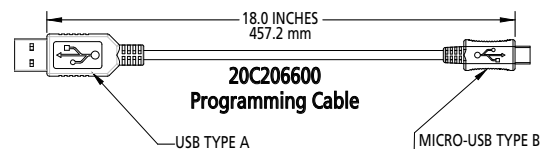

Battery Pack and Charger
included with tool in U.S.
and Canada only



Charger - 21R209500



Battery Pack - 21R209300

QPM Cordless Lever Tools (2.4 to 95 Nm)

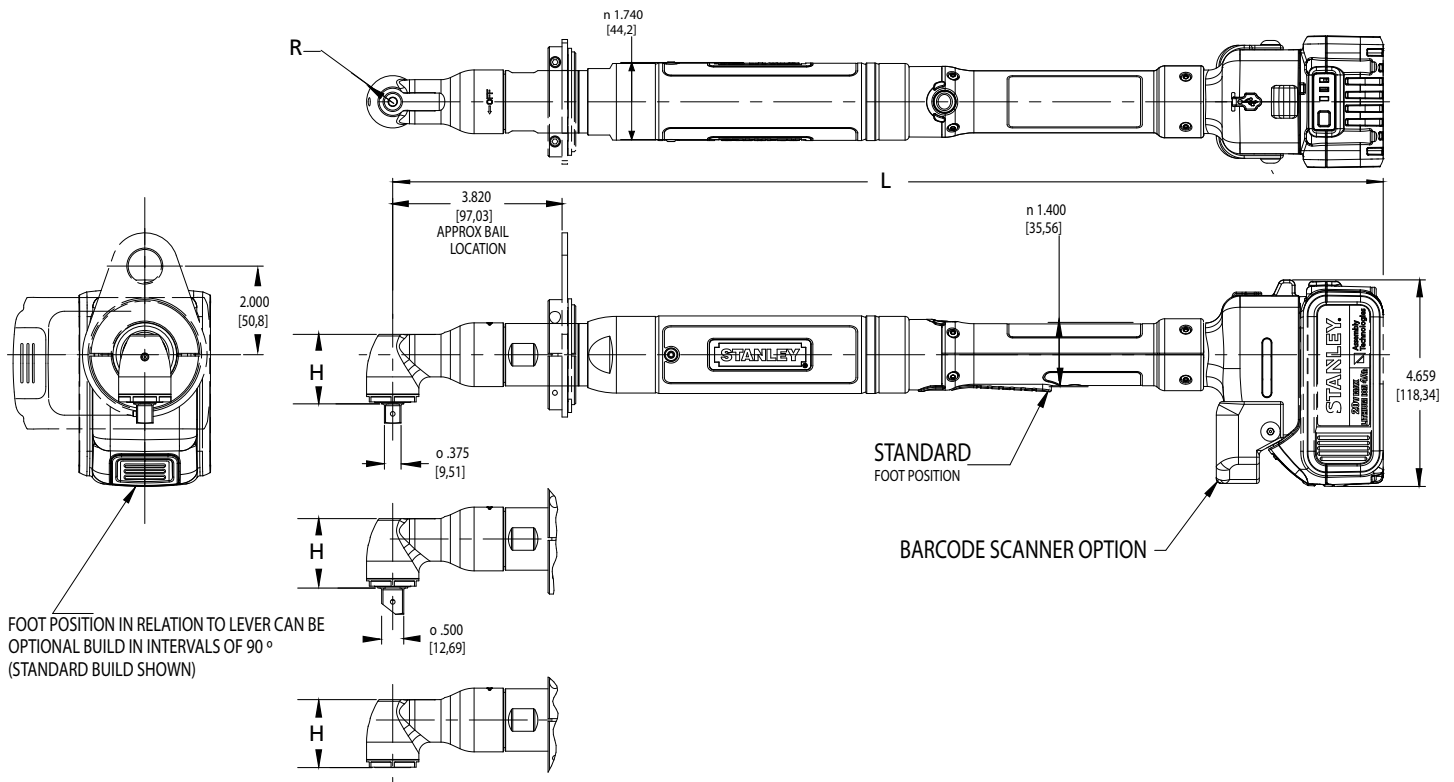

Model	Rated Speed		Torque		"R" Side to Center		"H" Head Height		"L" Length		Weight w/ Battery		Weight w/o Battery		Output	
	RPM		Nm	lb ft	mm	in	mm	in	mm	in	kg	lb	kg	lb	Standard	Options
B23LA13-12	665		12	8.8	13	0.5	33.2	1.3	537	21.2	2.41	5.3	1.74	3.8	3/8" SD	1/4" QC
B23LA13-17	460		17	12.5	13	0.5	33.2	1.3	537	21.2	2.41	5.3	1.74	3.8	3/8" SD	1/4" QC
B23LA15-23	370		23	17	15	0.59	39.9	1.57	552	21.8	2.58	5.7	1.95	4.3	3/8" SD	1/2" SD
B23LA15-35	230		35	25.8	15	0.59	39.9	1.57	567	22.4	2.65	5.8	1.98	4.4	3/8" SD	1/2" SD
B23LA18-42	180		42	31	18	0.71	39.9	1.57	563	22.2	2.83	6.2	2.11	4.6	3/8" SD	1/2" SD
B23LA19-52	155		52	38.3	19	0.75	47.8	1.9	592	23.4	2.99	6.6	2.32	5.1	1/2" SD	
B23LA19-70	140		70	51.6	19	0.75	47.8	1.9	653	25.7	3.61	7.9	2.95	6.5	1/2" SD	
B23LA22-95	105		95	70	22	0.87	47.9	1.9	660	26.0	3.61	7.9	2.95	6.5	1/2" SD	

Total vibration emission value: <2.5 m/sec² (ISO 28927-2:2009); Sound pressure level at work station LpA (ref 20µPa) is <70dB(A) (ISO 15744-2002).

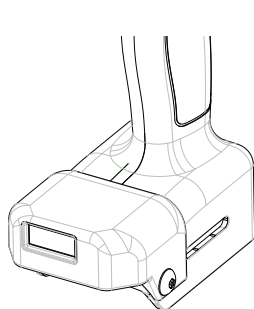

Barcode Scanner Option
B23L - 20H106200

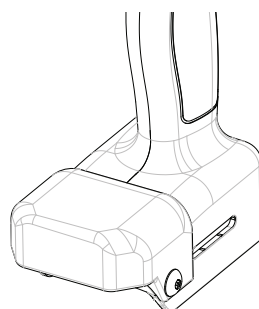

IEEE 802.15.4 Radio Option
B23L - 20H106202

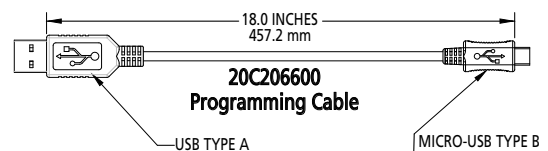

Battery Pack and Charger included with tool in U.S. and Canada only.



Charger - 21R209500



Battery Pack - 21R209300

B Series Cordless Lever Tools

QPM Cordless Tubenut/ Crowfoot Tools (2.6 to 38 Nm)

Tubenut

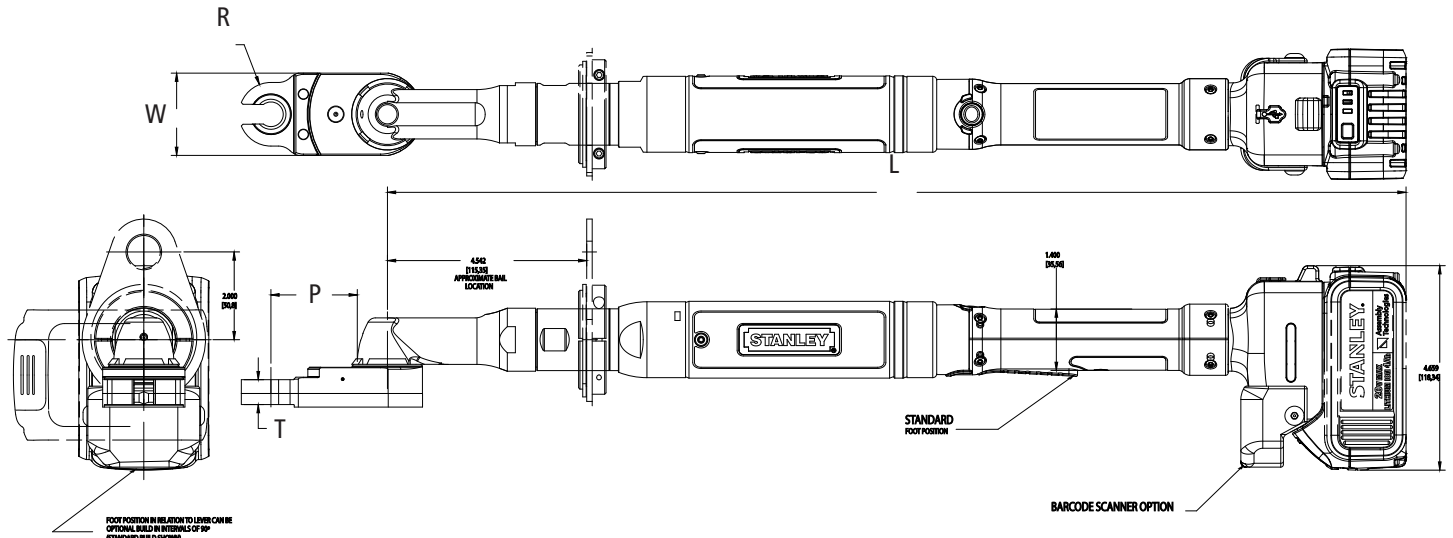

Model	Rated Speed		Torque		"R" Nose Radius		"T" Thickness		"W" Width		"P" Length		"L" Length		Weight		Maximum Hex Size		Maximum Tube Size	
	RPM		Nm	lb ft	mm	in	mm	in	mm	in	mm	in	mm	in	kg	lb	mm	in	mm	in
B23LT252-21	260	21	15.5	13	0.52	13	14	0.54	42	1.66	56	2.20	525	20.7	2.5	5.6	13	1/2	9.3	0.37
B23LT346-23	250	23	16.9	13	0.52	13	14	0.56	42	1.66	34	1.34	644	25.4	2.4	5.3	13	0.5	9.4	0.37
B23LT74-30	305	30	22.1	18	0.73	18	14	0.56	48	1.88	44	1.72	657	25.9	2.5	5.6	18	11/16	11.6	0.46
B23LT473-31	195	31	22.9	18	0.73	18	14	0.56	48	1.88	39	1.53	593	23.3	2.4	5.3	18	11/16	11.6	0.46
B23LT264-38	150	38	28.0	21	0.84	21	18	0.70	54	2.13	77	3.03	665	26.2	2.5	5.6	24	15/16	18.2	0.72

Total vibration emission value: <2.5 m/sec² (ISO 28927-2:2009); Sound pressure level at work station LpA (ref 20µPa) is < 70dB(A) (ISO 15744-2002).

Crowfoot

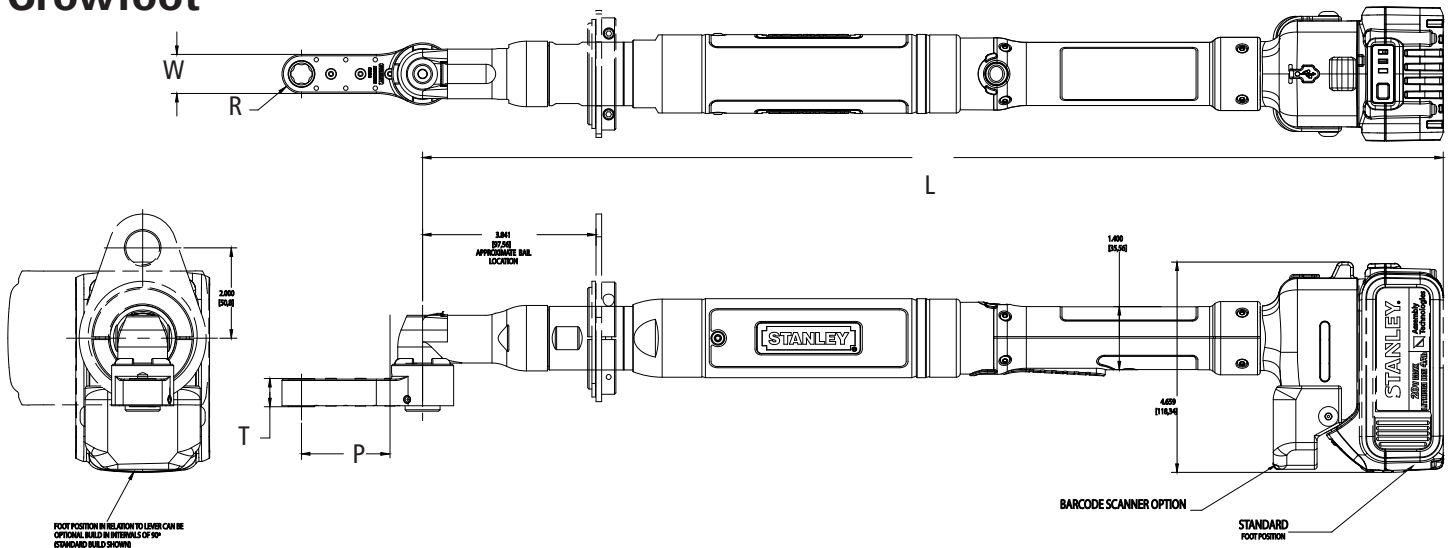

Model	Rated Speed		Torque		"R" Nose Radius		"T" Thickness		"W" Width		"P" Length		"L" Length		Weight		Maximum Hex Size	
	RPM		Nm	lb ft	mm	in	mm	in	mm	in	mm	in	mm	in	kg	lb	mm	in
B23LC550-13	460	13	9.6	9.6	13	0.5	9	0.37	25	1.00	77	3.05	629	24.8	2.5	5.6	13	0.5
B23LC390-15	335	15	11	11	11	0.43	16	0.63	22	0.87	51	1.99	642	25.3	2.4	5.3	13	0.5
B23LC29-37	160	37	27.3	27.3	21	0.81	14	0.55	38	1.50	43	1.70	590	23.2	2.4	5.3	19	0.75
B23LC566-38	155	38	28.0	28.0	21	0.81	21	0.81	38	1.50	43	1.70	593	23.3	2.4	5.3	19	0.75

Total vibration emission value: <2.5 m/sec² (ISO 28927-2:2009); Sound pressure level at work station LpA (ref 20µPa) is < 70dB(A) (ISO 15744-2002).

QPM Cordless Hold and Drive Tools (8.4 to 42 Nm)

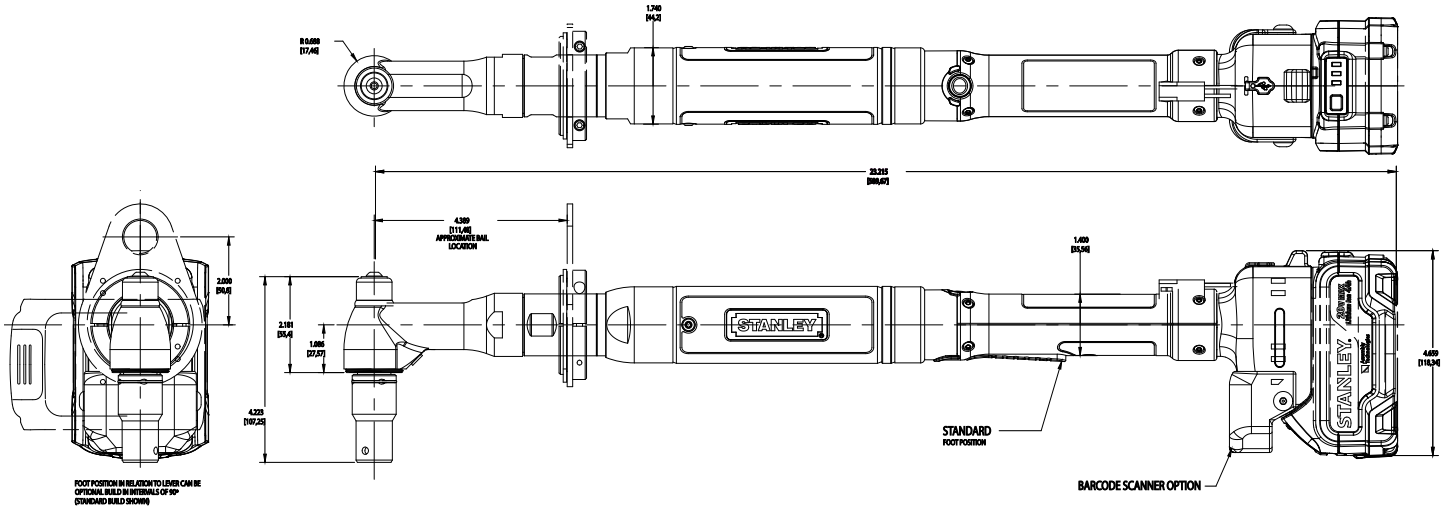

Model	Rated Speed	Torque		"R" Side to Center		"H" Head Height		"L" Length		Weight		Travel
	RPM	Nm	lb ft	mm	in	mm	in	mm	in	kg	lb	Standard
B23LH18V1-42	200	42	31	18	0.69	109	4.28	590	23.2	2	4.5	1" Tang
B23LH18V2-42	200	42	31	18	0.69	109	4.28	590	23.2	2.2	4.9	2" Tang

Total vibration emission value: <math><2.5 \text{ m/sec}^2</math> (ISO 28927-2:2009); Sound pressure level at work station LpA (ref 20 μ Pa) is <math><70\text{dB(A)}</math> (ISO 15744-2002).

Hold & Drive Options

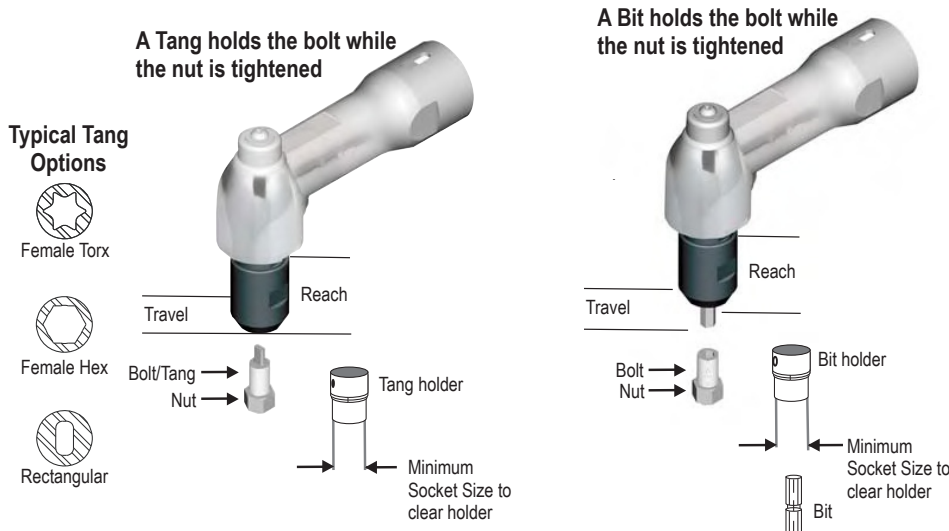

NOTE: The bolt can extend beyond the nut no more than the specified Travel distance when tightened.



E & EA Tools

This line of STANLEY DC tools has been engineered to combine the latest technologies with STANLEY's best design features resulting in best-in-class tools.

Features and Benefits:

- Full Line of Handheld Tools - Lever, Pistols, and Push-to-Start styles
- Full Line of Fixtured Tools - 0.6 Nm to 2005 Nm with geometries to fit any application
- Field Proven - Highest MTBF (Mean Time Between Failure) in the industry
- Modular Construction - For low MTTR (Mean Time To Repair).
 - » Common components reduce complexity.
 - » Handle/ Lever assembly common to all handheld tools.
 - » Entire tool line has
 - » 6 motor sizes
 - » 4 modular gear sets
 - » 7 angle heads that
 - » are field repairable
 - » have matched replacement gear sets
 - » Grease fittings on all angle, tubenut and crowfoot outputs for ease of preventive maintenance.



DC Electric Tool Model Number Scheme

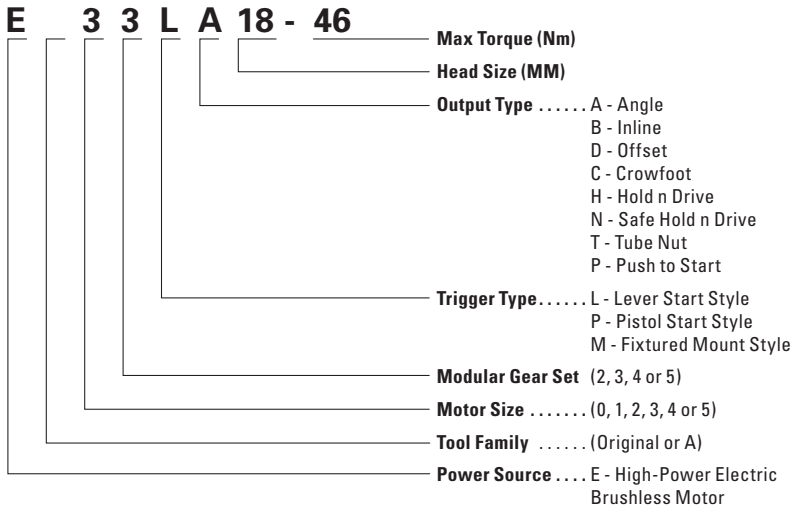

Angle tools can have gear case extensions to extend the reach of the tool. Simply add E# to the end of the tool model number to add the extended option to the tool when ordering. Where # is the length of the extension in 2 inch increments from 2 inches to 12 inches. See page 174.



Angle Lever Tools (0.8 to 21 Nm)

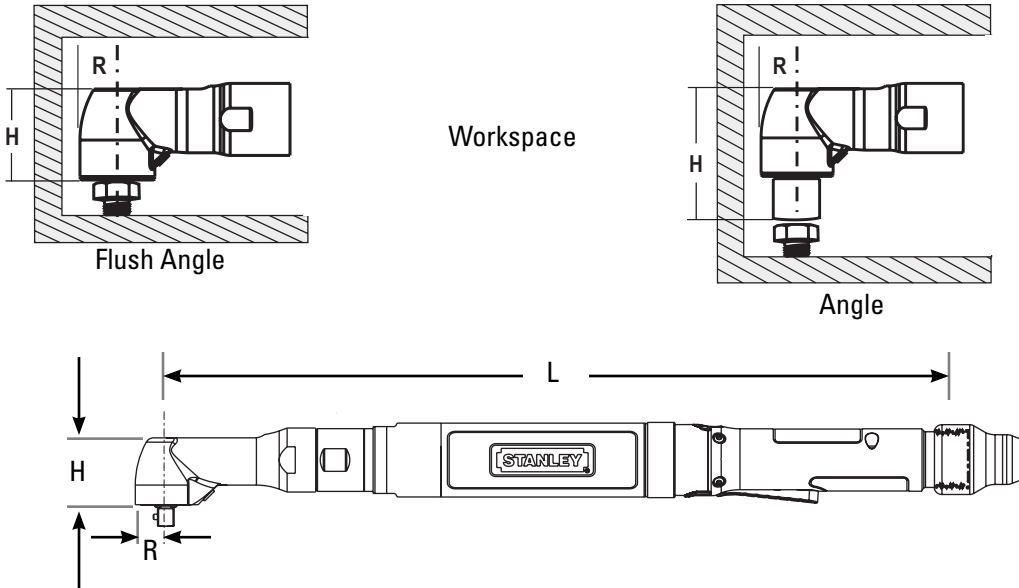

Model	Rated Speed		Torque		"R" Side to Center		"H" Head Height		"L" Length		Weight		Output
	RPM	Nm	lb ft	mm	in	mm	in	mm	in	kg	lb	Standard	
E12LA10-4	2325	4	2.95	10	0.39	31.9	1.26	271	10.7	0.7	1.6	1/4" SD	
EA23LA10-6	2875	6	4.42	10	0.39	31.9	1.26	376	14.8	1	2.2	1/4" SD	
E12LA10-6	1490	6	4.42	10	0.39	31.9	1.26	285	11.2	0.8	1.7	1/4" SD	
E12LA13-6	1690	6	4.42	13	0.51	32.7	1.29	287	11.3	0.8	1.7	3/8" SD	
EA23LA13-10	2090	10	7.4	13	0.51	32.7	1.29	379	14.9	1.1	2.4	3/8" SD	
E12LA13-10	1080	10	7.4	13	0.51	32.7	1.29	287	11.3	0.8	1.7	3/8" SD	
E23LA13-11	1500	11	8	13	0.51	32.7	1.29	435	17.1	1.5	3.3	3/8" SD	
E12LA13-14	850	14	10.3	13	0.51	32.7	1.29	287	11.3	0.8	1.7	3/8" SD	
E12LA14-17	565	17	12.5	14	0.55	36.5	1.44	297	11.7	0.9	1.9	3/8" SD	
EA23LA13-18	925	18	13.3	13	0.51	32.7	1.29	393	15.5	1.2	2.6	3/8" SD	
E12LA13-18	590	18	13.3	13	0.51	32.7	1.29	287	11.3	0.8	1.7	3/8" SD	
E12LA14-20	715	20	14.7	14	0.55	36.5	1.44	297	11.7	0.9	1.9	3/8" SD	
E12LA14-21	600	21	15.5	14	0.55	36.5	1.44	297	11.7	0.9	1.9	3/8" SD	

Angle Tool Output Options

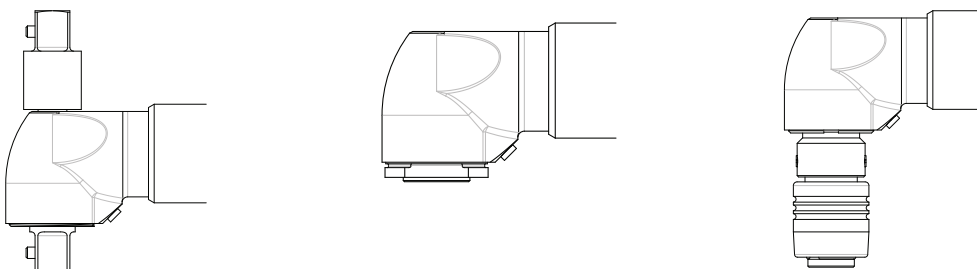

Double Ended

Flush

Quick Change

Angle Tool Options

A10 Output	Part No.
1/4" Square Drive	20D122900
3/8" Square Drive	20D122901
1/4" Quick Change	20D122902
A13 Short Output (E12 Models)	Part No.
3/8" Double-Ended, LH Thread	20D121912
3/8" Double-Ended, RH Thread	20D121917
Flush Socket 12mm Max*	20D121918
1/4" Square Drive	20D121919
1/4" Quick Change	20D121916
1/4" Magnetic Internal Hex	20D121920
A13 Long Output (E23 Models)	Part No.
3/8" Double-Ended, RH Thread	B3117
Rivnut Attachment	F3376
1/4" Square Drive	A3156
1/4" Magnetic Internal Hex	A3157
1/4" - 28 Threaded Female	A3351
3/8" - 24 Threaded Magnetic	A3158
5/16" - 24 Threaded Female	A3441
A14 Output	Part No.
1/4" Internal Hex	20D112110
Suspension Bails ***	Part No.
Standard Wire Bail	A3061
Swivel (E12 only)	20K101402
Swivel (E or EA 23/33 only)	20K101400
Vinyl Covers	Part No.
A10 Output	20D250711
A13 Output	20D250705
A14 Output	20D250701
2-Hand Anti-Tiedown	Part No.
E23 Tools	20G100104
EA Tools	Add TH
Socket Lock Pin 3/8" or 1/2" SD	Part No.
Standard	20D227800
Rounded (Ball Detent)	20D227801
Handle Options	Part No.
E12 / EA2/3 Rubber Grip	20H207910
E2/3/4/5 Rubber Grip	20H207207
E12 Extended Lever Assembly	20H102201
EA2/3 Front Facing Lever	20H100008
E2/3 Front Facing Lever	20H100005
E12 Heavy Duty Cable Adapter	20H103100
Other Options	Part No.
E12 LED Flexible Light Kit	20K101804
E12 LED Stationary Light Kit	20S113202

Guided Collar selection on page 175

*Flush socket selection starts on page 161

*** Suspension bails on page 174

E/ EA Series Angle Lever

Angle Tool Options

A15 Output	Part No.
3/8" Square Drive	20D138900
Flush Socket *	20D283200
1/2" Square Drive	20D138901
A18 Output	Part No.
3/8" Square Drive	F3825
3/8" Double-Ended, RH	A6466
3/8" Double-Ended, LH	F3828
1/2" Double-Ended, RH	A6473
1/2" Double-Ended, LH	F3830
Flush Socket 16mm Max*	F3834
1/4" Magnetic Internal Hex	F3832
5/16" Magnetic Internal Hex	F3833
3/8" - 24 Thread Female	F3831
3/8" Square Drive Paint Marking	F3973
Retractable Spindle†	L3150
3/8" Square Drive Anti-Vibration	20D104600
A19 Output	Part No.
3/8" Square Drive (48 Nm Max)	20D100005
1/2" Square Drive	20D100000
1/2" Square Drive Anti-Vibration	20D100001
1/2" Double-Ended, RH	20D100003
Flush Socket 17mm Max*	20D100007
2-Hand Anti-Tiedown	Part No.
E23 Tools	20G100015
E33 Tools (48 Nm Max)	20G100012
E33 Tools (60 Nm)	20G100013
E34 Tools	20G100414
EA Tools	Add TH
Suspension Bails ***	Part No.
Swivel (Horizontal)	20K101400
Standard (Vertical)	A3061
Vinyl Covers	Part No.
A15 Output	20D250701
A18 Output	20D250702
A19 Output	20D250707
Extended Packing Cap	Part No.
A15 Output	20D140103
A18 Output	20D140100
A19 Output	20D140101
Socket Lock Pin 3/8" or 1/2" SD	Part No.
Standard	20D227800
Rounded (Ball Detent)	20D227801
Handle Options	Part No.
EA2/3 Rubber Grip	20H207910
E2/3/4/5 Rubber Grip	20H207207
EA2/3 Front Facing Lever	20H100008
E2/3 Front Facing Lever	20H100005

Angle Lever Tools (4 to 60 Nm)

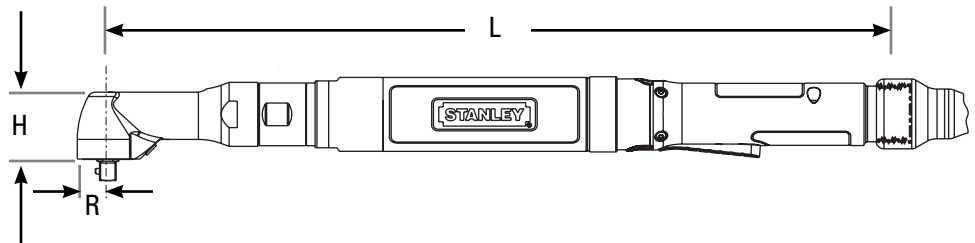

Model	Rated Speed		Torque		"R" Side to Center		"H" Head Height		"L" Length		Weight		Output
	RPM	Nm	lb ft	mm	in	mm	in	mm	in	kg	lb	Standard	
EA23LA15-20	1065	20	14.7	15	0.59	39.9	1.57	401	15.8	1.3	2.9	3/8" SD	
E23LA15-23	685	23	16.9	15	0.59	39.9	1.57	442	17.4	1.6	3.6	3/8" SD	
EA23LA15-29	740	29	21.4	15	0.59	39.9	1.57	401	15.8	1.3	2.9	3/8" SD	
E33LA15-35	865	35	25.8	15	0.59	39.9	1.57	468	18.4	1.8	4.0	3/8" SD	
E23LA15-35	415	35	25.8	15	0.59	39.9	1.57	442	17.4	1.6	3.6	3/8" SD	
EA33LA15-40	930	40	29.5	15	0.59	36.5	1.44	401	15.8	1.5	3.4	3/8" SD	
EA33LA18-40	930	40	29.5	18	0.71	39.3	1.55	426	16.8	1.7	3.8	3/8" SD	
EA33LA18-46	805	46	33.9	18	0.71	39.3	1.55	426	16.8	1.4	3.1	3/8" SD	
E33LA18-46	750	46	33.9	18	0.71	39.3	1.55	426	16.8	1.9	4.3	3/8" SD	
EA33LA19-48	780	48	35.4	19	0.75	49	1.9	492	19.4	1.9	4.1	3/8" SD	
E33LA19-48	730	48	35.4	19	0.75	49	1.9	492	19.4	2.2	4.8	3/8" SD	
E43LA19-60	700	60	44.3	19	0.75	49	1.9	517	20.3	2.6	5.8	1/2" SD	
EA33LA19-60	685	60	44.3	19	0.75	49	1.9	492	19.4	1.9	4.1	1/2" SD	
E33LA19-60	570	60	44.3	19	0.75	49	1.9	492	19.4	1.9	4.1	1/2" SD	

†Retractable Spindle Options

Square Drive	Extension	Travel	Part No.	Square Drive	Extension	Travel	Part No.
3/8"	Standard	1"	M4265	3/8"	6"	1"	20D118502
3/8"	1"	1"	20D118500	3/8"	7"	1"	20D118504
3/8"	2"	1"	M4266	1/2"	Standard	1"	M4289
3/8"	3"	1"	20D118501	1/2"	2"	1"	M4290
3/8"	4"	1"	20D118503				

Guided Collar selection on page 175
 *Flush socket selection starts on page 161
 *** Suspension bails on page 174

Angle Lever Tools (14 to 125 Nm)

Angle Tool Options

A19 Output	Part No.
1/2" Square Drive	20D100100
1/2" Square Drive Anti-Vibration	20D100101
1/2" Double-Ended, RH	20D100107
Flush Socket 17mm Max*	20D100106
A22(A) Output	Part No.
1/2" Square Drive	20D100305
Flush Socket 18mm Max*	20D100309
1/2" Double-Ended, RH	20D100326
2-Hand Anti-Tiedown Switch	Part No.
E34/44/54 Tools	20K400001
EA Tools	Add TH
Suspension Bails ***	Part No.
Swivel (Horizontal)	20K200000
Standard (Vertical)	A3061
Reaction Devices	Part No.
Reaction Bar	20K100000
Mounting Flange	20K100300
Base Mount Bracket	20K100500
Vinyl Covers	Part No.
A19 Output	20D250707
A22 Output	20D250708
Socket Lock Pin 3/8" or 1/2" SD	Part No.
Standard	20D227800
Rounded (Ball Detent)	20D227801
Handle Options	Part No.
EA3 Rubber Grip	20H207910
E2/3/4/5 Rubber Grip	20H207207
EA3 Front Facing Lever	20H100008
E3 Front Facing Lever	20H100005
E4/5 Front Facing Lever	20H100105
Motor Options	Part No.
E3 Tool Cooling Fan Kit	20M102600

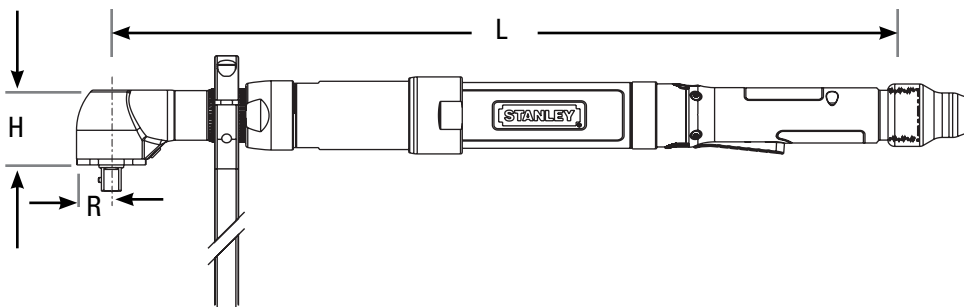

Model	Rated Speed		Torque		"R" Side to Center		"H" Head Height		"L" Length		Weight		Output
	RPM	Nm	lb ft	mm	in	mm	in	mm	in	kg	lb	Standard	
E34LA19-50	655	50	36.9	19	0.75	49	1.9	522	20.6	2.9	6.3	1/2" SD	
E44LA19-70	635	70	51.6	19	0.75	49	1.9	531	20.9	3.3	7.3	1/2" SD	
E34LA19-70	435	70	51.6	19	0.75	49	1.9	522	20.6	2.9	6.3	1/2" SD	
EA34LA19-80	530	80	59.0	19	0.75	49	1.9	506	19.9	2.4	5.3	1/2" SD	
EA34LA22A-100	410	100	73.8	22	0.88	50	2	514	20.2	2.7	5.9	1/2" SD	
E44LA22-101	545	101	74.5	22	0.88	50	2	539	21.2	3.5	7.6	1/2" SD	
E34LA22-101	335	101	74.5	22	0.88	50	2	530	20.9	3	6.6	1/2" SD	
E34LA22-115	300	115	84.8	22	0.88	50	2	530	20.9	3	6.6	1/2" SD	
E54LA22-120	470	120	88.5	22	0.88	50	2	742	29	4.75	10.5	1/2" SD	
E44LA22-120	360	120	88.5	22	0.88	50	2	539	21.2	3.5	7.6	1/2" SD	
EA34LA22A-120	340	120	88.5	22	0.88	50	2	514	20.2	2.7	5.9	1/2" SD	
E44LA22-125	405	125	92.2	22	0.88	50	2	539	21.2	3.5	7.6	1/2" SD	

Guided Collar selection on page 175
 *Flush socket selection starts on page 161
 *** Suspension bails on page 174

E Series Angle Lever

Angle Lever Tools (20 to 401 Nm)

Angle Tool Options

A26 Output (100 Nm Max)	Part No.
1/2" Square Drive	20D100401
5/8" Square Drive	20D100400
A26 Output	Part No.
3/4" Square Drive	20D1004010
Flush Socket *	20D100409
A32 Output	Part No.
3/4" Square Drive (Pin)	20D102200
3/4" Square Drive (Ball)	20D104300
Flush Socket *	20D102201
Hex Insert #	20D102204
2-Hand Anti-Tiedown Switch	Part No.
E34/44/54 Tools	20K400002
Reaction Bar (A26 & A32 Outputs)	Part No.
Reaction Bar, Steel (<300 Nm)	20K100200
Reaction Bar, Steel (>300 Nm)	20K100202
Base Mount Bracket	Part No.
Mounting Flange	20K100700
Suspension Bails ***	Part No.
Swivel (A26, A32 only)	20K200100
Vinyl Covers	Part No.
A26 Output	20D250709
A32 Output	20D250710
Socket Lock Pin 3/8" or 1/2" SD	Part No.
Standard	20D227800
Rounded (Ball Detent)	20D227801
Socket Lock PinLock Pin 3/4" SD	Part No.
Standard	20D227800
Rounded (Ball Detent)	20D227802
Handle Options	Part No.
E2/3/4/5 Rubber Grip	20H207207
E4/5 Front Facing Lever	20H100105

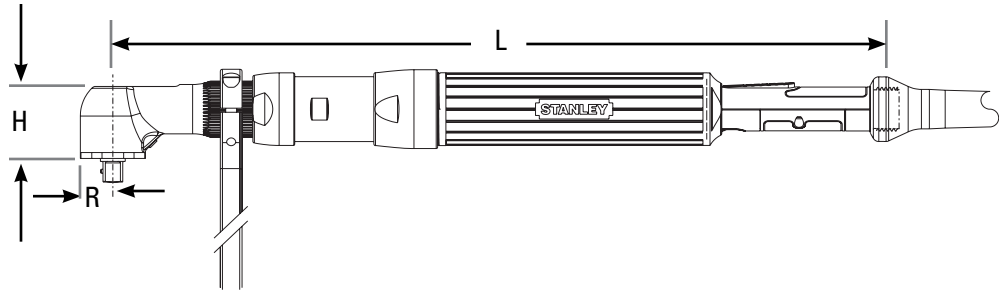

	Rated Speed	Torque		"R" Side to Center		"H" Head Height		"L" Length		Weight		Output
<i>Model</i>	<i>RPM</i>	<i>Nm</i>	<i>lb ft</i>	<i>mm</i>	<i>in</i>	<i>mm</i>	<i>in</i>	<i>mm</i>	<i>in</i>	<i>kg</i>	<i>lb</i>	<i>Standard</i>
E55LA26-100	880	100	74	26	1.02	60	2.4	632	24.9	5.8	12.8	1/2" SD
E55LA26-140	610	140	103	26	1.02	60	2.4	632	24.9	5.8	12.8	3/4" SD
E45LA26-150	330	150	110	26	1.02	60	2.4	582	22.9	5.2	11.5	3/4" SD
E55LA26-167	510	167	123	26	1.02	60	2.4	632	24.9	5.8	12.8	3/4" SD
E45LA26-201	265	201	148	26	1.02	60	2.4	582	22.9	5.2	11.5	3/4" SD
E55LA26-221	385	221	163	26	1.02	60	2.4	632	24.9	5.8	12.8	3/4" SD
E55LA32-337	255	337	248	32	1.26	73	2.9	639	25.1	6.5	14.2	3/4" SD
E55LA32-401	205	401	295	32	1.26	73	2.9	639	25.1	5.85	12.87	3/4" SD

#Inserts for 20D102204 A32 Hex Insert Output

Description	Part No.
1-1/8" Hex Socket Insert	A5172
30mm Hex Flush Socket Insert	20D222100
30mm with 3/4" Extension Flush Socket Insert	20D228900
1-1/16" Hex Socket Insert	20DS203600

The maximum hex size for the A32 Flush Socket Output is 27 mm (1-1/16").

Use the Hex Insert Output with these Inserts for larger hex sizes.

This will add 16.3 mm (0.64") to the "H" dimension of the tool.

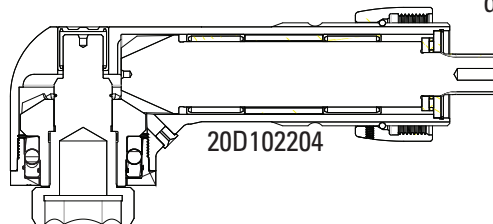

Mounting / Reaction Options

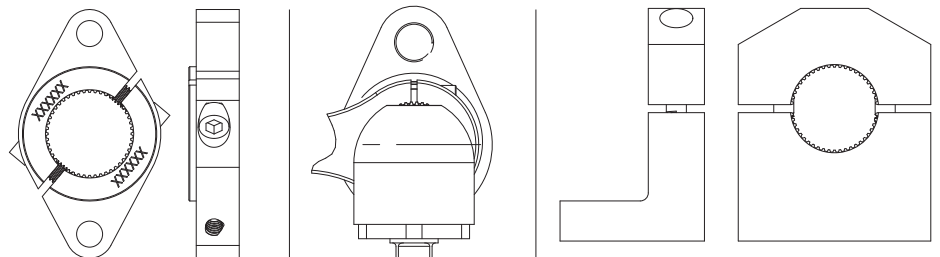

Optional Flange Mount Bracket

Reaction Bar or Bail

Optional Base Mount Bracket

Guided Collar selection on page 175
 *Flush socket selection starts on page 161
 *** Suspension bails on page 174

Pistol Grip Tools (0.3 to 100 Nm)

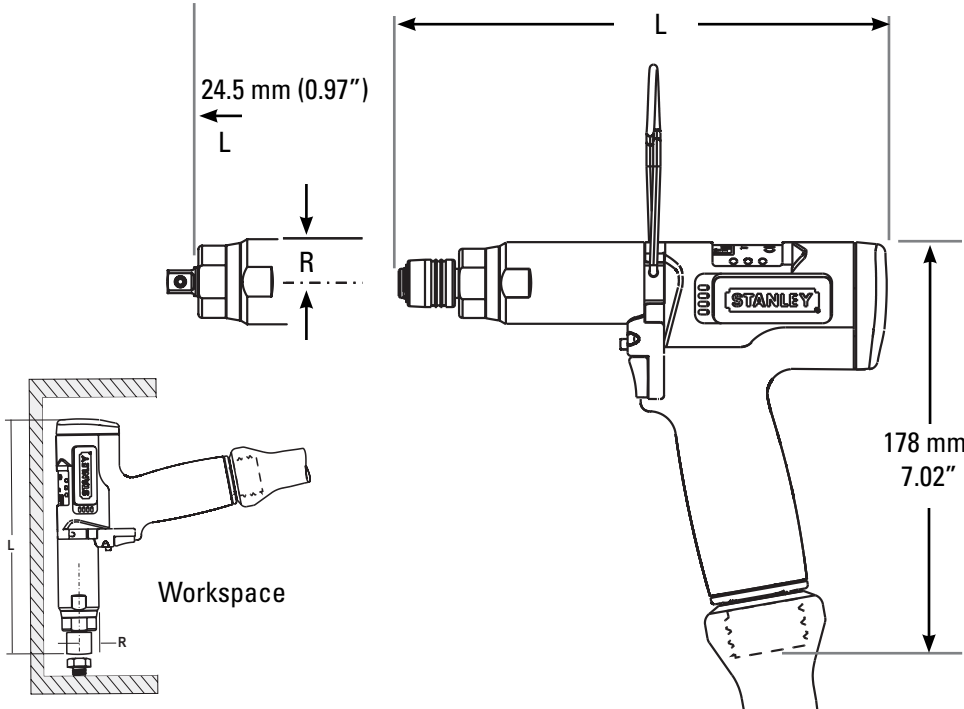

Model	Rated Speed		Torque		"R" Side to Center		"L" Length		Weight		Output
	RPM	Nm	lb ft	mm	in	mm	in	kg	lb	Standard	
E02PB-1.5	2040	1.5	1.1	18	0.7	211	8.3	0.74	1.6	1/4 QC	
E02PB-3	1620	3	2.2	18	0.7	211	8.3	0.74	1.6	1/4 QC	
E12PB-4	2535	4	2.9	20	0.8	222	8.7	0.8	1.8	1/4 QC	
E02PB-5	880	5	3.7	18	0.7	211	8.3	0.74	1.6	1/4 QC	
E12PB-10	1280	10	7.4	20	0.8	236	9.3	0.9	1.9	1/4 QC	
E12PB-13	880	13	9.5	20	0.8	212	8.3	0.9	1.9	1/4 QC	
E12PB-17	610	17	12.5	20	0.8	212	8.3	0.9	1.9	1/4 QC	

Model	Rated Speed		Torque		"R" Side to Center		"L" Length		Weight		Output
	RPM	Nm	lb ft	mm	in	mm	in	kg	lb	Standard	
E33PB-32	1125	32	23.6	26	1.04	288	11.3	1.6	3.5	3/8" SD	
E33PB-40	890	40	29.5	26	1.04	288	11.3	1.6	3.5	3/8" SD	
E34PB1-60	605	60	44.3	32	1.25	324	12.8	2.4	5.2	1/2" SD	
E34PB1-74	490	74	54.6	32	1.25	324	12.8	2.4	5.2	1/2" SD	
E34PB1-100	365	100	73.8	32	1.25	324	12.8	2.4	5.2	1/2" SD	

Pistol Tool Options

E0/E1 Output Options	Part No.
1/4" Square Drive	20D109007
1/4" Quick Change	20D109006
3/8" Square Drive	20D109008
E33 Output Options	Part No.
3/8" Square Drive Pin	20D100700
3/8" -24 Thread	20D100701
3/8" Square Drive Ball	20D100703
E34 Output Options	Part No.
1/2" Square Drive Pin	20D101001
1/2" Square Drive Ball	20D101004
1/2" Square Drive 6 Inch Extension	20D101003
Socket Lock Pin 3/8" or 1/2" SD	Part No.
Standard	20D227800
Rounded (Ball Detent)	20D227801
E0/E1 Reaction Components	Part No.
Spacer	20D217000
Reaction Bar, Aluminum 17"	20K100103
Reaction Bar, Steel 17"	20K100104
E33 Reaction Components	Part No.
Reaction Bar, Steel	20K100100
Base Mount Bracket	A8606
Mounting Flange	20K101000
E34 Reaction Components	Part No.
Reaction Bar, Steel	20K100000
Base Mount Bracket	20K100500
Mounting Flange	20K100300
Suspension Bail	Part No.
Wire Bail	A3061
Swivel E33 Tools	20K101400
Swivel E34 Tools	20K200000
Vertical Bail Kit E3 Pistol	20K200007
Cable Exit	Part No.
Bottom E0 Tools	20H206320
Bottom E1 Tools	20H206321
Bottom E3 Tools	20H207110
Top E0/E1 Tools	20H206319
Top E3 Tools	20H207114
Fan Parts	Part No.
E0/E1 Bottom Exit	20H206326
E3 Bottom Exit	20H207111
Handle Options	Part No.
Pistol Rubber Grip	20H207107
Motor Options	Part No.
E3 Tool Cooling Fan Kit	20M102600

Pistol Grip Tools (31 to 670 Nm)

Pistol Tool Options

B4 Output Options	Part No.
1" Square Drive Pin	20D208300
1" Square Drive Ball	20D208301
1" Square Drive x 1-1/2" Extension	20D208302
B2 Reaction Components	Part No.
Reaction Bar, Steel	20K100200
Reaction Bar, Steel Heavy Duty	20K100202
Base Mount Bracket	20K100600
Mounting Flange	20K100700
B4 Reaction Components	Part No.
Reaction Bar, Steel 10" Long	F4192
Reaction Bar, Steel 40" Long	N4500
Base Mount Bracket	F4201
Mounting Flange	20K101100
Reaction Bar with Adjustable 1" Square Drive Slave 4-1/2" ± 2-3/16" Radius	F4485
Reaction Bar with Adjustable 1" Square Drive Slave with Handle 4-1/2" ± 2-3/16" Radius	F4857
Reaction Bar with Adjustable 1" Square Drive Slave with Handle 17-3/4" ± 1-1/2" Radius	N4335
Reaction Bar with Adjustable 1" Square Drive Slave with Handle 18-3/4" ± 1-13/16" Radius	N4585
Reaction Bar with Adjustable 1" Square Drive Slave with Handle 7-1/2" ± 1-1/2" Radius	A6263
Suspension Bail	Part No.
Wire Bail	A3061
Swivel	20K200000
Vertical Bail Kit	20K200007
Cable Exit	Part No.
Bottom	20H207110
Top	20H207114
Fan Parts	Part No.
Bottom Exit	20H207111
Handle Options	Part No.
Pistol Rubber Grip	20H207107

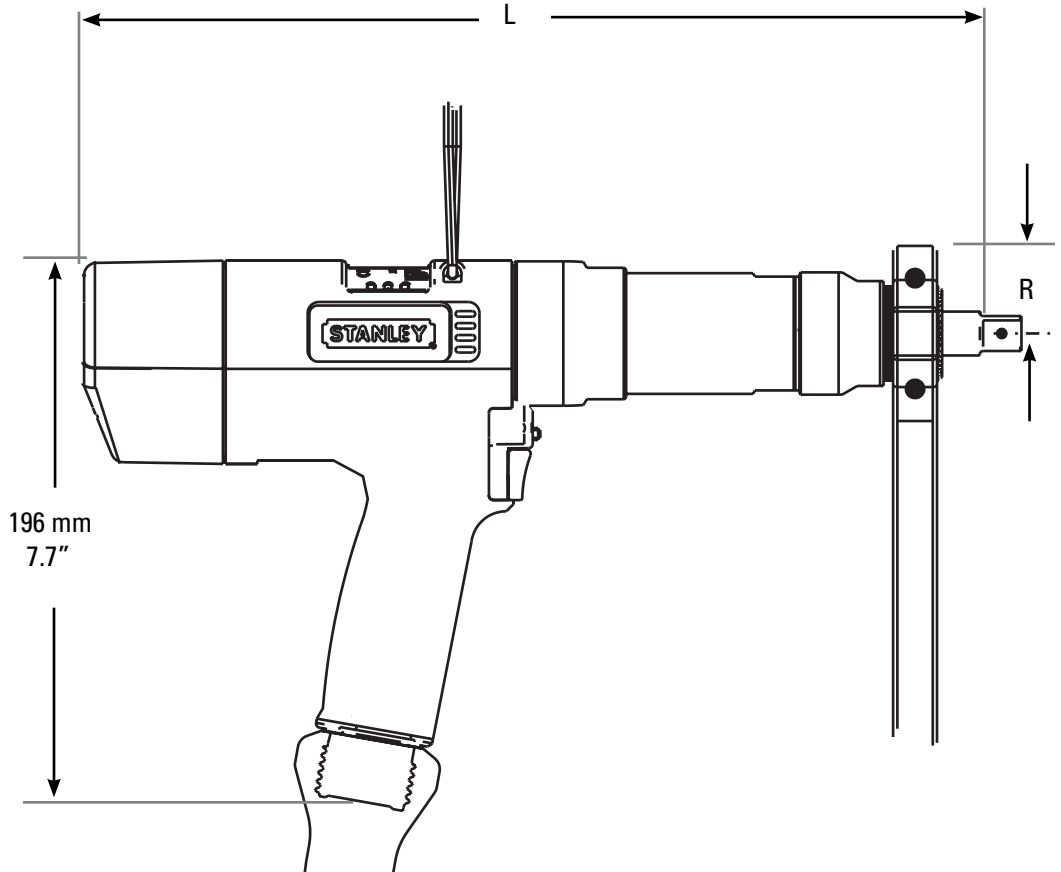

	Rated Speed	Torque		"R" Side to Center		"L" Length		Weight		Output
Model	RPM	Nm	lb ft	mm	in	mm	in	kg	lb	Standard
E35PB2-155	225	155	114	34	1.34	393	15.5	3.6	8	3/4" SD
E35PB4-271	100	271	200	44	1.72	431	17	6.8	15	1" SD
E35PB4-340	100	340	250	44	1.72	431	17	6.8	15	1" SD
E35PB4-670	40	670	494	44	1.72	431	17	6.8	15	1" SD

Mounting / Reaction Options

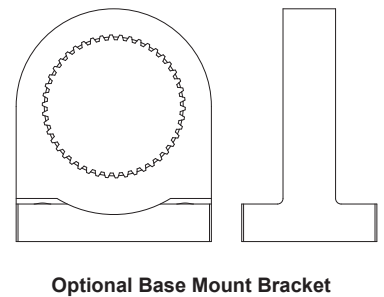
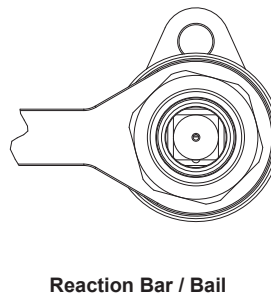
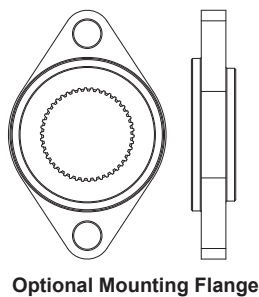
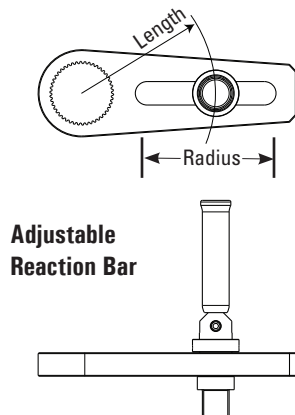

Swing Bar Pistol Grip Tools (9 to 1200 Nm)

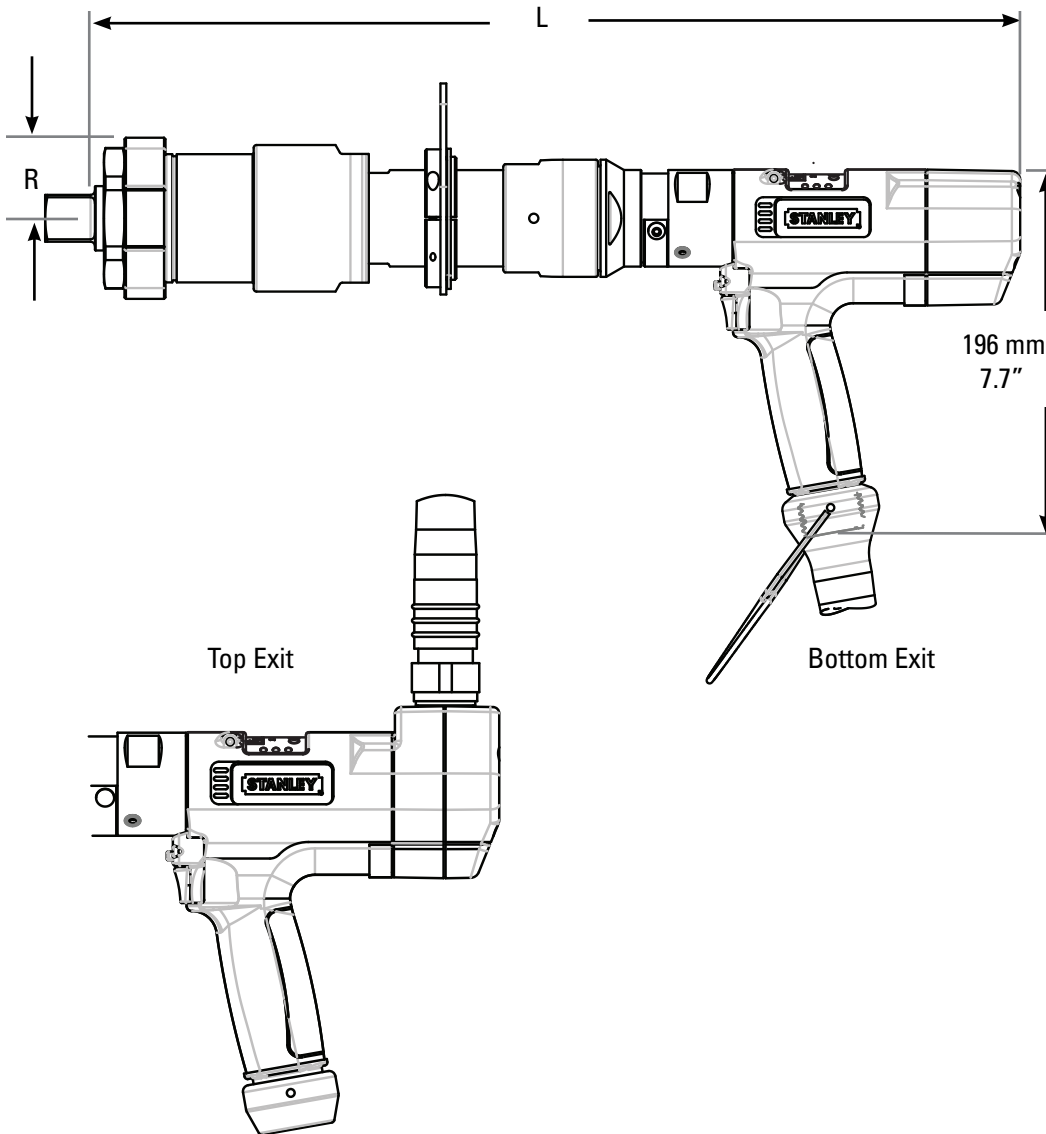

Pistol Tool Options

E33PB Output Options	Part No.
3/8" Square Drive Pin	20D100700
3/8" -24 Thread	20D100701
3/8" Square Drive Ball	20D100703
E34B1 Output Options <1200 Nm	Part No.
1/2" Square Drive Pin	20D101001
1/2" Square Drive Ball	20D101004
1/2" Square Drive 6 Inch Extension	20D101003
Socket Lock Pin 3/8" or 1/2" SD	Part No.
Standard	20D227800
Rounded (Ball Detent)	20D227801
E33 Reaction Components	Part No.
Reaction Bar, Steel	20K100100
Base Mount Bracket	A8606
Mounting Flange	20K101000
B1 Reaction Components <1200 Nm	Part No.
Reaction Bar, Steel	20K100000
B4 Reaction Components	Part No.
Reaction Bar, Steel 10" Long	F4192
Suspension Bail	Part No.
Wire Bail	A3061
Swivel E33 Tools	20K101400
Swivel E34 Tools	20K200000
Swivel E35 Tools	20K200001
Vertical Bail Kit	20K200007
Cable Exit	Part No.
Bottom	20H207110
Top	20H207114
Fan Parts	Part No.
Bottom Exit	20H207111
Handle Options	Part No.
Pistol Rubber Grip	20H207107

Model	Rated Speed		Torque		"R" Side to Center		"L" Length		Weight		Output
	RPM		Nm	lb ft	mm	in	mm	in	kg	lb	Standard
E33PBS0035-45	890		45	33	31.8	1.25	387	15.2	2.4	5.2	3/8" SD
E34PB1S0014-74	490		74	55	31.8	1.25	387	15.2	2.7	6	1/2" SD
E35PB4S0022-340	100		340	250	43.6	1.72	478	18.8	6.8	15	1" SD
E35PB4S0012-670	40		670	494	43.6	1.72	501	19.7	6.8	15	1" SD
E34PB1S0035-1200	6		1200	885	41.3	1.63	474	18.6	5.4	11.8	1" SD
E34PB1S0047-1200	6		1200	885	41.3	1.63	474	18.6	5.4	11.8	1" SD

E Series Inline PTS Lever

Inline Push-to-Start (PTS) Lever Tools (0.8 to 17 Nm)

PTS Tool Options

Output Options	Part No.
1/4" Square Drive	20D119305
3/8" Square Drive	20D109003
1/4" Quick Change	20D109004
3/8" SD Socket Lock Pin	Part No.
Standard	20D227800
Rounded (Ball Detent)	20D227801
Reaction Components	Part No.
Mounting Collar Kit	20K101700
Suspension Bail	Part No.
Wire Bail	A3061
Handle Options	Part No.
Rubber Grip	20H207915
Heavy Duty Cable Adapter	20H103100

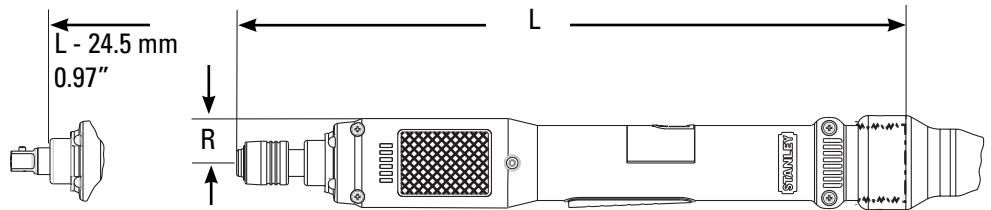

	Rated Speed	Torque		"R" Side to Center		"L" Length		Weight		Output
<i>Model</i>	<i>RPM</i>	<i>Nm</i>	<i>lb ft</i>	<i>mm</i>	<i>in</i>	<i>mm</i>	<i>in</i>	<i>kg</i>	<i>lb</i>	<i>Standard</i>
E12LP-4	2535	4	3	21	0.8	314	12.3	0.74	1.63	1/4" QC
E12LP-6	1620	6	4.4	21	0.8	314	12.3	0.74	1.63	1/4" QC
E12LP-10	1280	10	7.4	21	0.8	314	12.3	0.74	1.63	1/4" QC
E12LP-13	880	13	9.5	21	0.8	314	12.3	0.74	1.63	1/4" QC
E12LP-17	610	17	12.5	21	0.8	314	12.3	0.74	1.63	1/4" QC

Inline Tool Options

Output Options	Part No.
3/8" Square Drive	20D109008
1/4" Quick Change	20D109006
1/4" Square Drive	20D109007
3/8" SD Socket Lock Pin	Part No.
Standard	20D227800
Rounded (Ball Detent)	20D227801
Reaction Bar	Part No.
Reaction Bar, Aluminum	20K100103
Reaction Bar, Steel	20K100104
Spacer	20D217000
Suspension Bails ***	Part No.
Wire Bail	A3061
Swivel	20K101402
Handle Options	Part No.
Rubber Grip	20H207910
Extended Lever	20H102201
Heavy Duty Cable Adapter	20H103100
Light Option	Part No.
E12 LED Flexible Light Kit	20K101804
E12 LED Stationary Light Kit	20S113202

Inline Lever Tools (0.8 to 17 Nm)

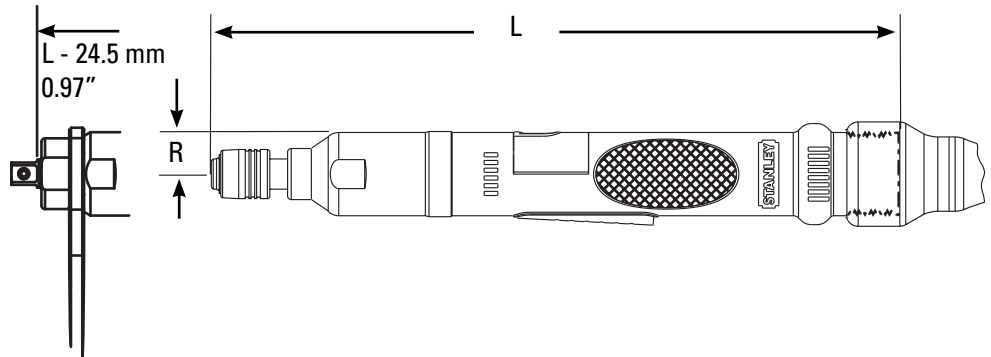

	Rated Speed	Torque		"R" Side to Center		"L" Length		Weight		Output
<i>Model</i>	<i>RPM</i>	<i>Nm</i>	<i>lb ft</i>	<i>mm</i>	<i>in</i>	<i>mm</i>	<i>in</i>	<i>kg</i>	<i>lb</i>	<i>Standard</i>
E12LB-4	2535	4	3	18	0.7	282	11.1	0.7	1.54	1/4" QC
E12LB-6	1620	6	4.4	18	0.7	282	11.1	0.7	1.54	1/4" QC
E12LB-10	1280	10	7.4	18	0.7	282	11.1	0.7	1.54	1/4" QC
E12LB-13	880	13	9.5	18	0.7	282	11.1	0.7	1.54	1/4" QC
E12LB-17	610	17	12.5	18	0.7	282	11.1	0.7	1.54	1/4" QC

*** Suspension bails on page 174

**Inline Lever Tools
(1.4 to 40 Nm)**

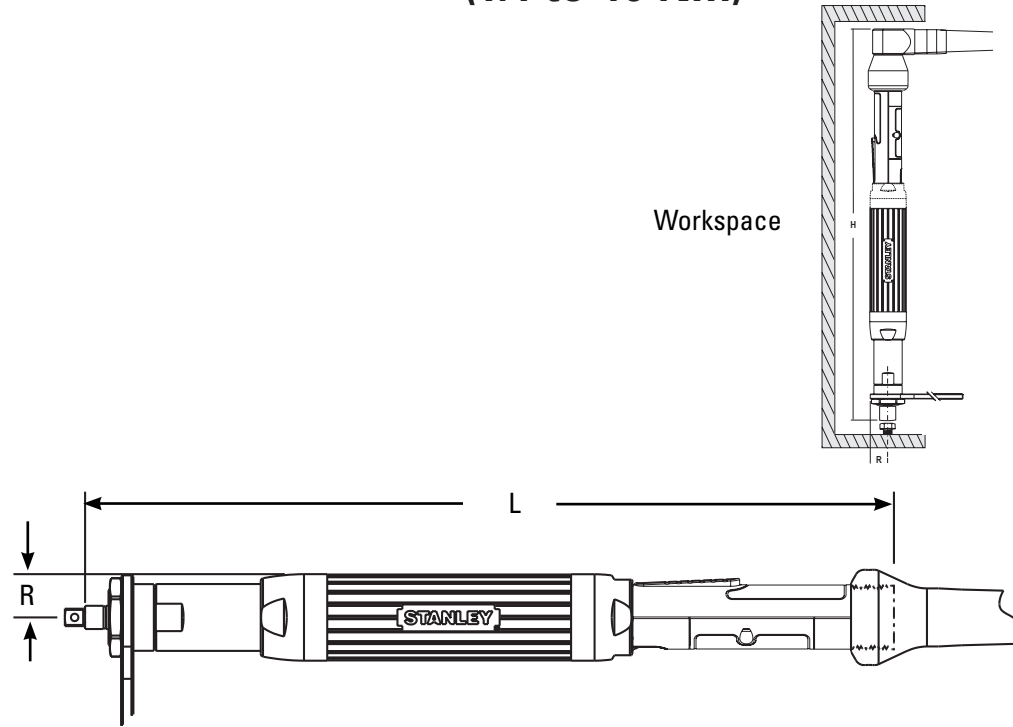

Inline Tool Options - LB

Output Options	Part No.
3/8" 24-Thread	20D100701
3/8" Square Drive	20D100600
3/8" Square Drive x 8" Extension	20D100702
1/4" Quick Change (17 Nm max)	20D101100
Lock Nut Options	Part No.
Lock Nut	F3697
Pinch Point	20D243501
Guided Collar	20D243502
Reaction Bar	Part No.
Reaction Bar, Aluminum	F3698
Reaction Bar, Steel	20K100100
Base Mount Bracket	A8606
Mounting Flange-B	20K101000
3/8" SD Socket Lock Pin	Part No.
Standard	20D227800
Rounded (Ball Detent)	20D227801
Suspension Bails***	Part No.
Wire Bail	A3061
Swivel	20K101400
Standard	B3432
Handle Options	Part No.
EA Tool Rubber Grip	20H207910
E Tool Rubber Grip	20H207207
EA Tool Front Facing Lever	20H100008
E Tool Front Facing Lever	20H100005
Motor Options	Part No.
E Tool Cooling Fan Kit	20M102600

Model	Rated Speed	Torque		"R" Side to Center		"L" Length		Weight		Output
	RPM	Nm	lb ft	mm	in	mm	in	kg	lb	Standard
EA23LB-7	3140	7	5.1	21	0.8	386	15.2	1.3	2.9	3/8" SD
E23LB-8	2245	8	5.9	24	0.9	402	15.8	1.4	3.1	3/8" SD
EA23LB-12	1390	12	8.9	21	0.8	401	15.8	1.3	2.9	3/8" SD
EA33LB-15	3465	15	11	21	0.8	412	16.2	1.4	3.1	3/8" SD
E23LB-16	1000	16	11.8	24	0.9	402	15.8	1.4	3.1	3/8" SD
EA23LB-21	965	21	15.5	21	0.8	401	15.8	1.3	2.9	3/8" SD
E23LB-21	785	21	15.5	24	0.9	417	16.4	1.6	3.5	3/8" SD
EA33LB-25	1530	25	18.4	21	0.8	427	16.8	1.4	3.1	3/8" SD
EA23LB-31	665	31	22.9	21	0.8	401	15.8	1.3	2.9	3/8" SD
E23LB-31	540	31	22.9	24	0.9	417	16.4	1.6	3.5	3/8" SD
EA33LB-32	1210	32	23.6	21	0.8	427	16.8	1.4	3.1	3/8" SD
E23LB-32	1125	32	23.6	24	0.9	442	17.4	1.7	3.8	3/8" SD
EA33LB-40	1065	40	29.5	21	0.8	427	16.8	1.4	3.1	3/8" SD
E33LB-40	890	40	29.5	24	0.9	442	17.4	1.7	3.8	3/8" SD

Mounting / Reaction Options

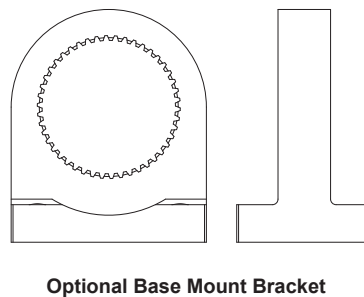
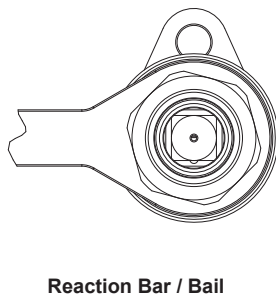
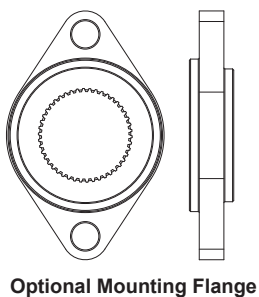

*** Suspension bails on page 174

E/ EA Series Inline Lever

Inline Lever Tools (12 to 100 Nm)

Inline Tool Options - LB1

Output Options	Part No.
1/2" Square Drive x 6" Extension	20D101003
1/2" SD Socket Lock Pin	Part No.
Standard	K4024
Rounded (Ball Detent)	K4050
2-Hand Anti-Tiedown Switch	Part No.
E34/44/54 Tools	20K400002
EA Tools	Add TH
Reaction Components	Part No.
Reaction Bar	20K100000
Mounting Flange	20K100300
Base Mount Bracket	20K100500
Suspension Bail***	Part No.
Wire Bail	A3061
Swivel Bail	20K200000
Handle Options	Part No.
E Tool Rubber Grip	20H207207
EA Tool Rubber Grip	20H207910
E Tool Front Facing Lever	20H100005
EA Tool Front Facing Lever	20H100008

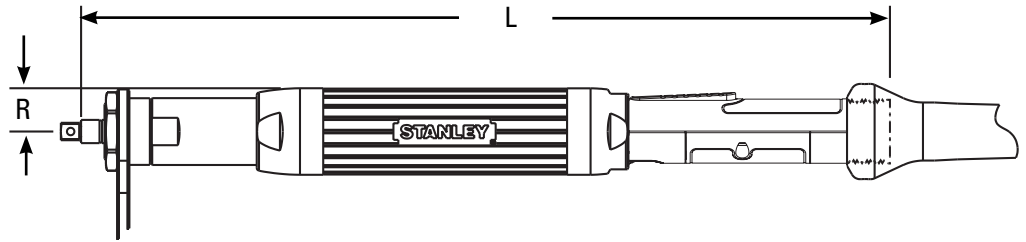

Model	Rated Speed	Torque		"R" Side to Center		"L" Length		Weight		Output
	RPM	Nm	lb ft	mm	in	mm	in	kg	lb	Standard
EA34LB1-60	745	60	44	25	1	463	18.2	1.9	4.2	1/2" SD
E34LB1-60	605	60	44	32	1.25	478	18.8	2.4	5.2	
E44LB1-66	885	66	49	32	1.25	487	19.2	2.9	6.4	
EA34LB1-74	490	74	55	25	1	463	18.2	1.9	4.2	
E34LB1-74	490	74	55	32	1.25	478	18.8	2.4	5.2	
E44LB1-100	590	100	74	32	1.25	487	19.2	2.9	6.4	
EA34LB1-100	365	100	74	25	1	463	18.2	1.9	4.2	
E34LB1-100	365	100	74	32	1.25	478	18.8	2.4	5.2	

Inline Lever Tools (32 to 250 Nm)

Inline Tool Options - LB2

Output Options	Part No.
5/8" Square Drive	20D102502
3/4" Square Drive x 8" Extension	20D102603
3/4" Square Drive x 12" Extension	20D102604
Socket Lock Pin	Part No.
Standard 3/4"	A5075
Standard 5/8"	A4026
Rounded (Ball Detent)	20R202300
2-Hand Anti-Tiedown Switch	Part No.
E55 Tools	20K400008
Reaction Components	Part No.
Reaction Bar	20K100200
Reaction Bar - Heavy Duty	20K100202
Mounting Flange	20K100700
Base Mount Bracket	20K100600
Suspension Bail***	Part No.
Wire Bail	A3061
Swivel Bail	20K200100
Handle Options	Part No.
Rubber Grip	20H207207
Front Facing Lever	20H100105

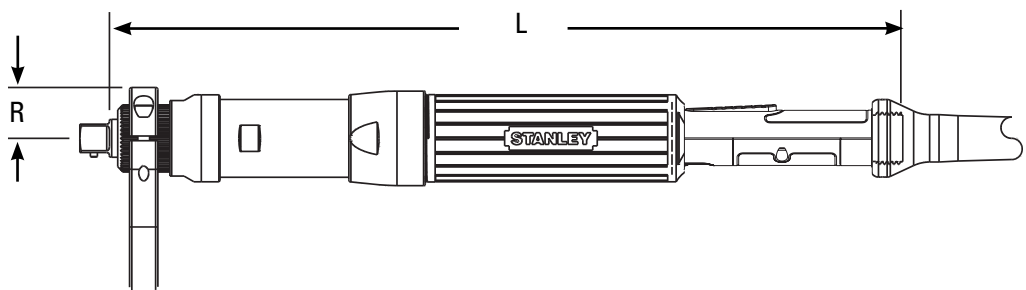

Model	Rated Speed	Torque		"R" Side to Center		"L" Length		Weight		Output
	RPM	Nm	lb ft	mm	in	mm	in	kg	lb	Standard
E55LB2-127	720	127	94	34	1.35	560	22.1	4.7	10.3	3/4" SD
E45LB2-160	345	160	118	34	1.35	533	21	4.4	9.6	
E55LB2-200	475	200	147	34	1.35	560	22.1	4.7	10.3	
E55LB2-250	380	250	184	34	1.35	560	22.1	4.7	10.3	
E45LB2-250	220	250	184	34	1.35	533	21	4.4	9.6	

*** Suspension bails on page 174

**Inline Lever Tools
(64 to 2005 Nm)**

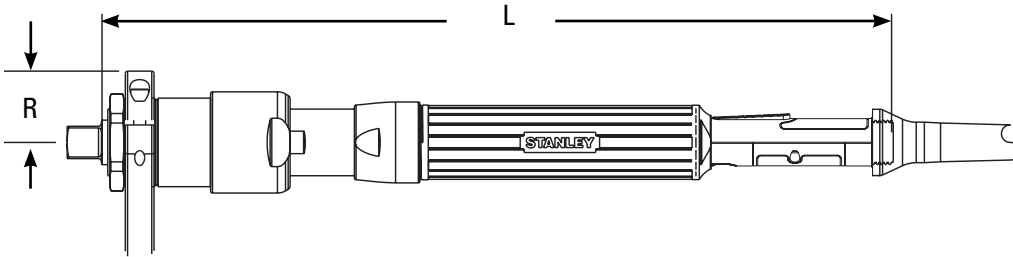

Model	Rated Speed		Torque		"R" Side to Center		"L" Length		Weight		Output
	RPM	Nm	lb ft	mm	in	mm	in	kg	lb	Standard	
E55LB3-322	230	322	237	32	1.25	573	22.5	5.3	11.5	3/4" SD	
E55LB4-471	185	471	347	44	1.7	621	24.4	7.4	16.3	1" SD	
E55LB4-623	140	623	459	44	1.7	621	24.4	7.4	16.3		
E55LB5-1023	75	1023	754	48	1.9	651	25.6	9.6	21.1		
E55LB5-1637	45	1637	1207	48	1.9	683	26.9	12	26.4		
E55LB5-2005	35	2005	1479	48	1.9	683	26.9	12	26.4		

Inline Tool Options - LB3/4/5

Output Options	Part No.
B3 3/4" SD with Ball Retainer	20D104502
B4 1" SD with 1 1/2" Extension	20D208302
Lock Nut Options	Part No.
Lock Nut - B3	B4484
2-Hand Anti-Tiedown Switch	Part No.
E55 Tools	20K400008
Reaction Components	Part No.
Reaction Bar - B3	B4487
Reaction Bar - B4, B5 <1500 Nm	F4192
Reaction Bar - B5 >1500 Nm	J4228
Base Mount Bracket - B3	H1140
Mounting Flange - B3	M4329
Mounting Flange - B4	20K101100
Mounting Flange - B5	20K100900
Socket Lock Pin	Part No.
Standard - B3	A5075
Rounded (Ball Detent) - 3/4", 1" SD	20R202300
Suspension Bails***	Part No.
Wire Bail	A3061
Swivel	20K200100
Handle Options	Part No.
E Tool Rubber Grip	20H207207
E Tool Front Facing Lever	20H100105

Mounting / Reaction Options

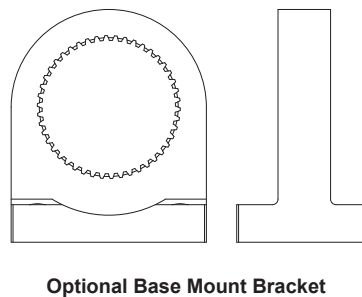
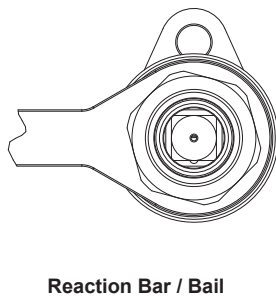
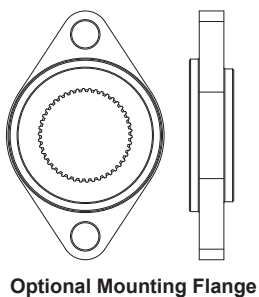

Guided Collar selection on page 175
 *** Suspension bails on page 174

E/ EA Series Crowfoot Lever

Angle Crowfoot Lever Tools (1.2 to 18 Nm)

Angle Crowfoot Tool Options

Suspension Bails	Part No.
Optional Wire Bail	A3061
Swivel Bail	20K101400
Standard Wire Bail	B3432
2-Hand Anti-Tiedown	Part No.
E23 Tools	20G100104
EA Tools	Add TH
Handle Options	Part No.
E12 / EA2/3 Rubber Grip	20H207910
E2/3/4/5 Rubber Grip	20H207207
E12 Extended Lever Assembly	20H102201
EA2/3 Front Facing Lever	20H100008
E2/3 Front Facing Lever	20H100005
E12 Heavy Duty Cable Adapter	20H103100
Other Options	Part No.
E12 LED Flexible Light Kit	20K101804
E12 LED Stationary Light Kit	20S113202
See Page 176 for Crowfoot Vinyl Cover Options	
See Page 151 for Crowfoot Socket Selection	

CROWFOOT CAN BE WELDED AT VARIOUS ANGLES. CONTACT STANLEY ASSEMBLY TECHNOLOGIES FOR MORE INFORMATION

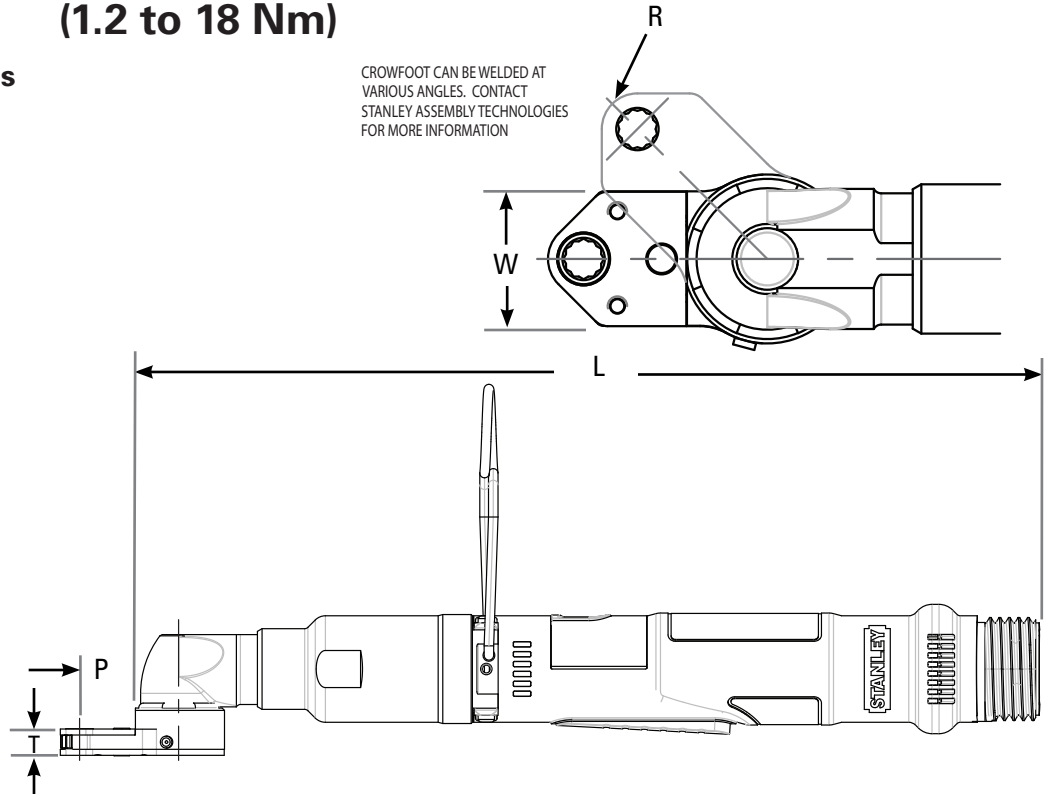

Model	Rated Speed	Torque		"R" Nose Radius		"T" Thickness		"W" Width		"P" Length		"L" Length		Weight		Maximum Hex Size	
	RPM	Nm	lb ft	mm	in	mm	in	mm	in	mm	in	mm	in	kg	lb	mm	in
E12LC44-6	1140	6	4.4	6	0.25	9	0.35	24	0.96	19	0.74	347	13.7	1.0	2.2	6	1/4"
E23LC8-8	1495	8	5.9	13	0.52	16.2	0.64	25.4	1	44.6	1.76	495	19.5	1.0	2.2	13	1/2"
E23LC64-8	790	8	5.9	10	0.39	9	0.35	24	0.96	55	2.16	447	17.6	1.0	2.2	13	1/2"
E12LC294-8	760	8	5.9	9	0.36	9	0.35	24	0.96	119	4.67	421	16.6	1.0	2.2	11	3/8"
E12LC8-13	585	13	9.6	13	0.52	16.2	0.64	25.4	1	44.6	1.76	347	13.7	1.0	2.2	13	1/2"
E12LC247-13	730	13	9.6	10	0.38	16	0.63	25	1	42	1.64	355	14.0	1.0	2.2	11	7/16"
E12LC445-13	585	13	9.6	13	0.52	16	0.63	25	1	45	1.76	347	13.7	1.0	2.2	13	1/2"
E12LC504-13	730	13	9.6	11	0.41	16	0.63	25	1	42	1.64	355	14.0	1.0	2.2	11	7/16"
E12LC106-14	585	14	10	13	0.52	16.2	0.64	25.4	1	64.6	2.54	367	14.5	1.1	2.3	13	1/2"
E23LC160-14	660	14	10	13	0.52	9	0.37	25	1	45	1.76	523	20.6	1.1	2.4	13	1/2"
E12LC420-14	585	14	10	13	0.52	16	0.63	25	1	65	2.54	367	14.5	1.1	2.4	13	1/2"
E23LC278-15	785	15	11	21	0.81	14	0.55	38	1.5	170	6.70	701	27.6	1.1	2.4	19	3/4"
EA23LC69-15	820	15	11	13.5	0.53	16.2	0.64	32	1.25	47	1.86	498	17.8	1.5	3.4	13	1/2"
E23LC69-15	745	15	11	13.5	0.53	16.2	0.64	32	1.25	47	1.86	532	20.9	2.3	5	13	1/2"
EA23LC8-16	730	16	11.8	13	0.52	16.2	0.64	25.4	1	44.6	1.76	453	17.8	1.4	3.1	13	1/2"
E23LC8-16	660	16	11.8	13	0.52	16.2	0.64	25.4	1	44.6	1.76	510	20.0	1.7	3.8	13	1/2"
E12LC8-16	430	16	11.8	13	0.52	16.2	0.64	25.4	1	44.6	1.76	453	17.8	1.21	2.66	13	1/2"
E23LC35-16	660	16	11.8	21	0.81	14	0.55	38	1.5	75	2.95	559	22	2.7	6	19	3/4"
E12LC69-16	485	16	11.8	13.5	0.53	16.2	0.64	32	1.25	47	1.86	449	17.7	2.7	6	13	1/2"
E23LC106-16	660	16	11.8	13	0.52	16.2	0.64	25	1	65	2.54	530	20.8	1.8	4	13	1/2"
E23LC246-16	660	16	11.8	16	0.63	21	0.81	32	1.25	48	1.9	535	21.1	1.8	4	14	9/16"
E23LC247-16	610	16	11.8	10	0.38	16	0.63	25	1	42	1.64	514	20.2	1.8	4	11	7/16"
EA23LC13-18	720	18	13.3	13.5	0.53	20.5	0.81	32	1.25	47	1.86	498	19.6	2.2	5	13	1/2"
E23LC13-18	590	18	13.3	13.5	0.53	20.5	0.81	32	1.25	47	1.86	533	21	2.4	5.2	13	1/2"
E23LC390-18	590	18	13.3	11	0.43	16	0.63	22	0.87	51	1.99	585	23.0	2.4	5.2	13	1/2"

Angle Crowfoot Lever Tools (5.4 to 42 Nm)

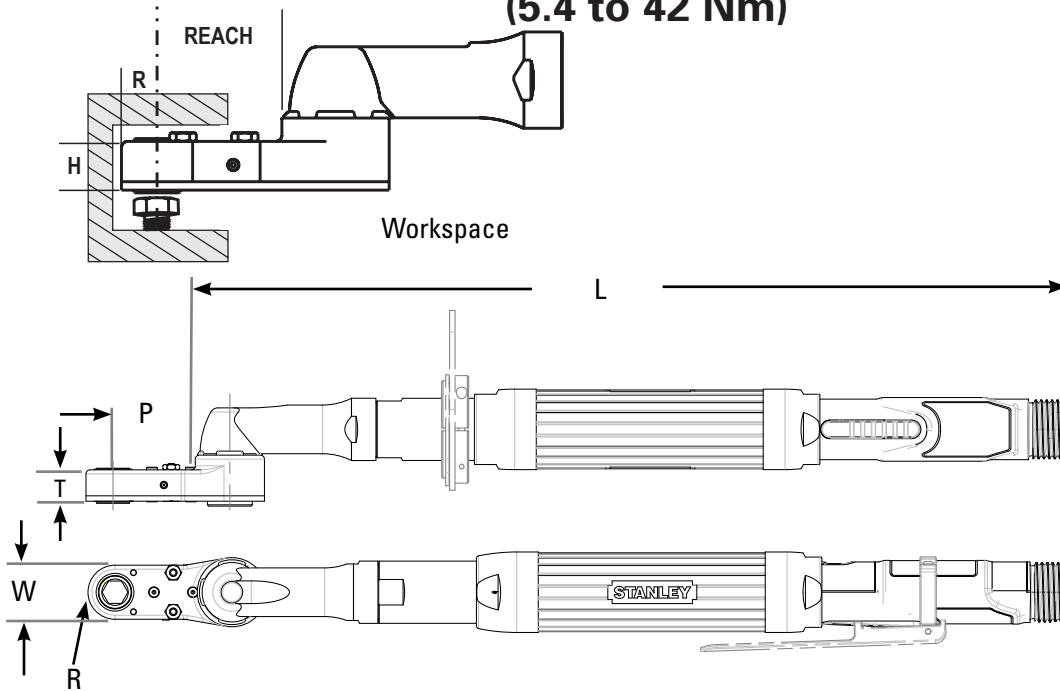

Angle Crowfoot Tool Options

2-Hand Anti-Tiedown	Part No.
E23 Tools	20G100015
E33 Tools (48 Nm Max)	20G100012
E33 Tools (60 Nm)	20G100013
E34 Tools	20G100414
EA Tools	Add TH
Suspension Bails	Part No.
Optional Wire Bail	A3061
Swivel Bail	20K101400
Handle Options	Part No.
EA2/3 Rubber Grip	20H207910
E2/3/4/5 Rubber Grip	20H207207
EA2/3 Front Facing Lever	20H100008
E2/3 Front Facing Lever	20H100005
See Page 176 for Crowfoot Vinyl Cover Options	
See Page 151 for Crowfoot Socket Selection	

Model	Rated Speed	Torque		"R" Nose Radius		"T" Thickness		"W" Width		"P" Length		"L" Length		Weight		Maximum Hex Size	
	RPM	Nm	lb ft	mm	in	mm	in	mm	in	mm	in	mm	in	kg	lb	mm	in
E33LC173-27	845	27	19.9	13	0.53	16	0.63	32	1.25	93	3.66	603	23.7	2.4	5.2	13	1/2"
E33LC69-27	845	27	19.9	13	0.53	16	0.63	32	1.25	47	1.86	557	21.9	2.4	5.3	13	1/2"
EA33LC69-27	905	27	19.9	13	0.53	16	0.63	32	1.25	47	1.86	523	20.6	2.4	5.3	13	1/2"
E33LC216-27	845	27	19.9	13	0.50	14	0.56	30	1.19	47	1.86	557	21.9	2.4	5.3	13	1/2"
E33LC13-30	760	30	22	13	0.53	21	0.81	32	1.25	47	1.86	557	21.9	2.5	5.5	13	1/2"
EA33LC13-30	795	30	22	13	0.53	21	0.81	32	1.25	47	1.86	523	20.6	2.5	5.5	13	1/2"
E33LC279-30	760	30	22	12	0.47	16	0.63	32	1.25	47	1.86	557	21.9	2.5	5.5	13	1/2"
E33LC308-30	760	30	22	13	0.53	21	0.81	32	1.25	70	2.76	580	22.8	2.5	5.5	13	1/2"
E33LC327-30	810	30	22	12	0.47	16	0.63	32	1.25	46	1.83	557	21.9	2.5	5.5	13	1/2"
E33LC333-30	760	30	22	13	0.53	21	0.81	32	1.25	93	3.66	603	23.7	2.5	5.5	13	1/2"
E33LC385-30	810	30	22	12	0.47	16	0.63	32	1.25	69	2.73	579	22.8	2.5	5.5	13	1/2"
EA33LC394-30	635	30	22	13	0.53	21	0.81	32	1.25	55	2.18	505	19.9	2.5	5.5	13	1/2"
EA33LC423-30	560	30	22	16	0.63	21	0.83	32	1.25	136	5.36	583	23.0	2.5	5.5	16	5/8"
EA33LC535-30	780	30	22	13	0.53	21	0.81	32	1.25	48	1.90	527	20.8	2.5	5.5	14	9/16"
E33LC35-31	750	31	22.9	21	0.81	14	0.55	38	1.50	75	2.95	585	23.0	2.9	6.3	19	3/4"
E33LC496-31	570	31	22.9	21	0.81	14	0.55	38	1.50	170	6.70	682	26.9	2.9	6.3	19	3/4"
E33LC16-35	750	35	25.8	21	0.81	21	0.81	38	1.50	75	2.95	585	23.0	2.6	5.7	19	3/4"
E33LC121-35	650	35	25.8	21	0.81	14	0.55	38	1.50	138	5.45	652	25.7	2.9	6.3	19	3/4"
E33LC29-35	675	35	25.8	21	0.81	14	0.55	38	1.50	43	1.70	548	21.6	2.9	6.3	19	3/4"
EA33LC29-35	685	35	25.8	21	0.81	14	0.55	38	1.50	43	1.70	527	20.7	2.9	6.3	19	3/4"
E33LC246-38	675	38	28	16	0.63	21	0.81	32	1.25	48	1.90	574	22.6	2.9	6.3	14	9/16"
EA33LC246-38	710	38	28	16	0.63	21	0.81	32	1.25	48	1.90	524	20.6	2.9	6.3	14	9/16"
E33LC297-38	590	38	28	16	0.63	21	0.81	32	1.25	71	2.80	581	22.8	2.9	6.3	14	9/16"
E33LC39-42	590	42	30.9	21	0.81	21	0.84	38	1.50	43	1.70	556	21.9	2.9	6.3	19	3/4"

E/ EA Series Crowfoot Lever

Angle Crowfoot Tool Options

2-Hand Anti-Tiedown Switch	Part No.
E34/44/54 Tools	20K400001
EA Tools	Add TH
Suspension Bails ***	Part No.
Swivel (Horizontal)	20K200000
Standard (Vertical)	A3061
Reaction Components	Part No.
Reaction Bar	20K100000
Mounting Flange	20K100300
Base Mount Bracket	20K100500
Handle Options	Part No.
EA3 Rubber Grip	20H207910
E2/3/4/5 Rubber Grip	20H207207
EA3 Front Facing Lever	20H100008
E3 Front Facing Lever	20H100005

Angle Crowfoot Lever Tools (8 to 132 Nm)

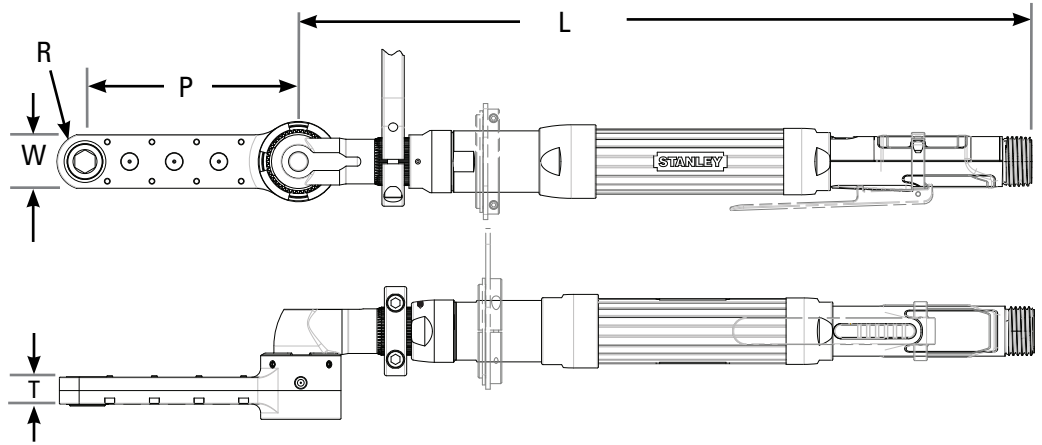

Model	Rated Speed RPM	Torque		"R" Nose Radius		"T" Thickness		"W" Width		"P" Length		"L" Length		Weight		Maximum Hex Size	
		Nm	lb ft	mm	in	mm	in	mm	in	mm	in	mm	in	kg	lb	mm	in
E34LC402-40	435	40	29.5	16	0.63	19	0.74	32	1.25	53	2.08	596	23.4	3.36	7.4	14	9/16"
E34LC29-45	435	45	33.2	21	0.81	14	0.55	38	1.50	43	1.70	586	23.1	3.36	7.4	19	3/4"
EA34LC29-45	530	45	33.2	21	0.81	14	0.55	38	1.50	43	1.70	570	22.5	3.36	7.4	19	3/4"
E34LC7-47	435	47	34.7	21	0.81	21	0.84	38	1.50	43	1.70	584	23.0	3.68	8.1	19	3/4"
E34LC10-49	385	49	36.1	21	0.81	28	1.10	38	1.50	71	2.78	625	24.6	3.68	8.1	19	3/4"
EA34LC10-49	445	49	36.1	21	0.81	28	1.10	38	1.50	71	2.78	610	24.0	3.63	8.0	19	3/4"
E34LC355-55	415	55	40.6	16	0.63	26	1.01	32	1.25	29	1.15	599	23.6	3.63	8.0	16	5/8"
E34LC66-55	435	55	40.6	16	0.63	21	0.84	32	1.25	28	1.12	548	21.6	3.63	8.0	14	9/16"
E34LC162-56	385	56	41.3	13	0.52	21	0.82	38	1.50	97	3.82	652	25.7	3.63	8.0	13	1/2"
E34LC226-59	410	59	43.5	17	0.66	17	0.66	38	1.50	68	2.69	619	24.4	3.63	8.0	16	5/8"
EA34LC456-60	470	60	44.3	20	0.79	17	0.65	38	1.48	123	4.85	658	25.9	3.91	8.6	19	3/4"
E34LC187-60	335	60	44.3	21	0.81	15	0.58	38	1.50	102	4.03	657	25.9	3.91	8.6	19	3/4"
E34LC272-60	370	60	44.3	16	0.63	26	1.01	32	1.25	131	5.15	685	27.0	3.91	8.6	16	5/8"
E34LC321-60	385	60	44.3	13	0.52	21	0.82	38	1.50	34	1.32	588	23.2	3.41	7.5	13	1/2"
E34LC515-60	310	60	44.3	12	0.48	25	0.99	38	1.50	125	4.94	585	23.0	3.95	8.7	12	7/16"
E34LC162-61	385	61	45	13	0.52	21	0.82	38	1.50	97	3.82	652	25.7	3.77	8.3	13	1/2"
E34LC316-61	375	61	45	17	0.66	21	0.82	38	1.50	100	3.94	655	25.8	3.77	8.3	16	5/8"
E34LC481-61	325	61	45	13	0.52	21	0.82	38	1.50	65	2.57	620	24.4	3.77	8.3	13	1/2"
E34LC523-61	385	61	45	17	0.66	21	0.82	38	1.50	97	3.82	652	25.7	3.77	8.3	13	1/2"
E34LC100-62	385	62	45.7	13	0.52	28	1.12	38	1.50	97	3.82	652	25.7	3.77	8.3	13	1/2"
E34LC200-70	325	70	51.6	21	0.81	20	0.78	38	1.50	134	5.28	689	27.1	3.77	8.3	19	3/4"
E34LC316-70	375	70	51.6	17	0.66	21	0.82	38	1.50	100	3.94	655	25.8	3.77	8.3	16	5/8"
E34LC324-70	325	70	51.6	21	0.81	20	0.78	38	1.50	71	2.78	625	24.6	3.77	8.3	19	3/4"
E34LC203-73	295	73	53.8	21	0.81	17	0.66	38	1.50	71	2.78	625	24.6	3.55	7.8	19	3/4"
EA34LC531-80	340	80	59	20	0.81	15	0.60	73	2.89	18	0.71	601	23.7	3.55	7.8	18	11/16"
EA34LC10-88	360	88	64.9	21	0.81	28	1.10	38	1.50	71	2.78	610	24.0	3.63	8.0	19	3/4"
EA34LC520-90	245	90	66.4	27	1.08	19	0.75	55	2.16	56	2.22	596	23.5	3.63	8.0	24	15/16"
E34LC396-95	205	95	70	20	0.79	20	0.78	38	1.48	123	4.85	673	26.5	3.63	8.0	19	3/4"
E34LC464-95	230	95	70	17	0.66	20	0.78	38	1.48	121	4.76	673	26.5	3.63	8.0	16	5/8"
E34LC256-132	180	132	97.3	27	1.08	19	0.75	55	2.16	56	2.22	610	24.0	3.63	8.0	24	15/16"

Angle Crowfoot Lever Tools (7 to 600 Nm)

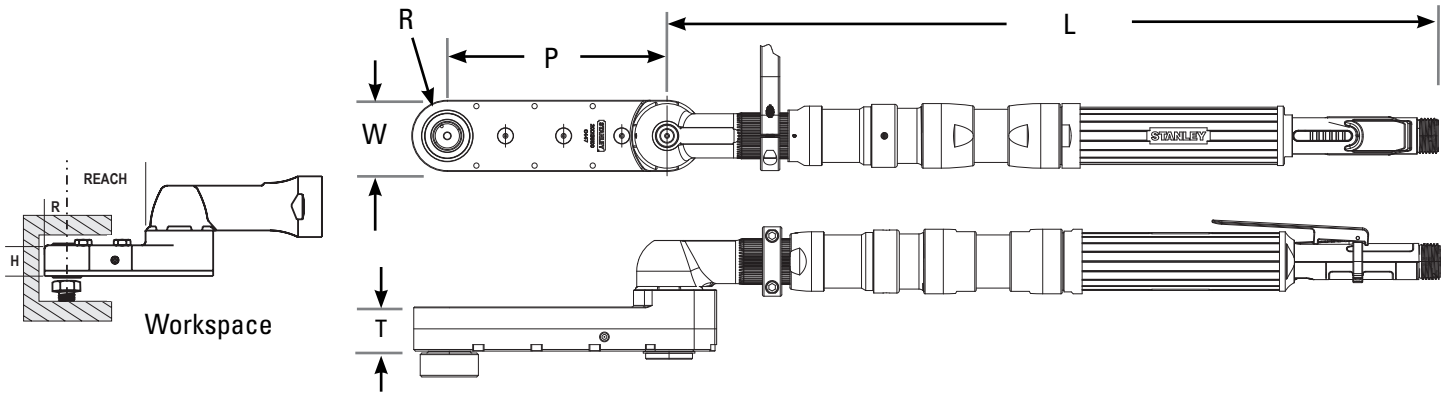

Model	Rated Speed	Torque		"R" Nose Radius		"T" Thickness		"W" Width		"P" Length		"L" Length		Weight		Maximum Hex Size	
	RPM	Nm	lb ft	mm	in	mm	in	mm	in	mm	in	mm	in	kg	lb	mm	in
E44LC508-35	715	35	25.8	13	0.53	14	0.57	32	1.25	47	1.86	596	23.5	4.9	10.9	13	1/2"
E44LC536-35	890	35	25.8	13	0.53	14	0.57	32	1.25	76	3.00	639	25.2	4.9	10.9	13	1/2"
E44LC226-54	595	54	39.8	17	0.66	17	0.66	38	1.50	68	2.69	635	25.0	4.9	10.9	16	5/8"
E44LC491-54	525	54	39.8	13	0.52	17	0.66	38	1.50	68	2.69	627	24.7	4.9	10.9	13	1/2"
E44LC100-62	530	62	45.7	13	0.52	28	1.12	38	1.50	97	3.82	661	26.0	4.9	10.9	13	1/2"
E44LC316-71	405	71	52.4	17	0.66	21	0.82	38	1.50	100	3.94	663	26.1	4.9	10.9	16	5/8"
E44LC404-75	355	75	55.3	17	0.66	26	1.03	38	1.50	68	2.69	633	24.9	4.9	10.9	16	5/8"
E45LC365-80	445	80	59	13	0.52	28	1.12	38	1.50	97	3.82	713	28.1	4.9	10.9	13	1/2"
E44LC172-80	360	80	59	21	0.81	28	1.12	38	1.50	166	6.54	730	28.7	4.9	10.9	19	3/4"
E44LC10-88	355	88	64.9	21	0.81	28	1.12	38	1.50	71	2.78	633	24.9	3.8	8.4	19	3/4"
E44LC31-88	355	88	64.9	21	0.81	28	1.10	38	1.50	39	1.53	602	23.7	3.6	8.0	19	3/4"
E44LC201-90	415	90	66.4	21	0.81	25	0.99	49	1.94	86	3.40	650	25.6	4.9	10.9	19	3/4"
E44LC329-90	415	90	66.4	21	0.81	23	0.91	49	1.94	86	3.40	650	25.6	4.9	10.9	19	3/4"
E44LC10-102	355	102	75.2	21	0.81	28	1.12	38	1.50	71	2.78	631	24.9	4.9	10.9	19	3/4"
E44LC31-102	355	102	75.2	21	0.81	28	1.10	38	1.50	39	1.53	602	23.7	3.6	8.0	19	3/4"
E44LC260-110	360	110	81.1	17	0.69	15	0.60	73	2.89	18	0.71	582	22.9	4.9	10.9	18	11/16"
E45LC284-125	280	125	92.2	29	1.16	31	1.22	59	2.31	147	5.79	758	29.8	4.9	10.9	27	1-1/8"
E45LC21-125	280	125	92.2	29	1.16	31	1.22	59	2.31	58	2.27	669	26.3	4.9	10.9	27	1-1/8"
E45LC85-131	285	131	96.6	29	1.13	22	0.87	59	2.31	58	2.27	698	27.5	4.9	10.9	27	1-1/8"
E45LC238-140	265	140	103	25	1.00	31	1.22	59	2.31	54	2.13	666	26.2	4.9	10.9	21	13/16"
E55LC364-145	385	145	107	20	0.80	35	1.37	39	1.53	46	1.81	708	27.9	4.9	10.9	19	3/4"
E55LC98-147	325	147	108	29	1.16	31	1.22	59	2.31	103	4.06	765	30.1	4.9	10.9	27	1-1/8"
E55LC323-150	385	150	111	25	1.00	22	0.87	59	2.31	99	3.92	761	30.0	4.9	10.9	24	15/16"
E45LC323-150	185	150	111	25	1.00	22	0.87	59	2.31	99	3.92	733	28.9	4.9	10.9	24	15/16"
E55LC98-184	215	184	136	29	1.16	31	1.22	59	2.31	103	4.06	794	31.3	4.9	10.9	27	1-1/8"
E45LC238-196	185	196	145	25	1.00	31	1.22	59	2.31	54	2.13	688	27.1	4.9	10.9	21	13/16"
E45LC21-216	155	216	159	29	1.16	31	1.22	59	2.31	58	2.27	692	27.2	4.5	10	27	1-1/8"
E55LC409-350	90	350	258	44	1.74	47	1.85	95	3.75	89	3.51	766	30.2	4.9	10.9	44	1-3/4"
E55LC446-350	230	350	258	29	1.16	49	1.92	59	2.31	101	3.96	893	35.2	4.9	10.9	27	1-1/8"
E55LC451-350	155	350	258	25	0.99	47	1.87	95	3.75	147	5.78	824	32.4	4.9	10.9	24	15/16"
E55LC458-350	90	350	258	44	1.74	38	1.50	95	3.75	89	3.51	766	30.2	4.9	10.9	44	1-3/4"
E55LC293-540	110	540	398	44	1.74	47	1.87	95	3.75	238	9.36	915	36.0	4.9	10.9	44	1-3/4"
E55LC447-550	70	550	406	35	1.38	42	1.67	70	2.76	152	6.00	974	38.3	4.9	10.9	41	1-5/8"
E55LC293-600	85	600	443	44	1.74	47	1.85	95	3.75	238	9.36	915	36.0	4.9	10.9	44	1-3/4"
E55LC447-600	70	600	443	35	1.38	42	1.67	70	2.76	152	6.00	974	38.3	4.9	10.9	41	1-5/8"

E/ EA Series Crowfoot Lever

Vertical Crowfoot Tool Options

Suspension Bails	Part No.
Swivel Bail	20K101400
Standard Wire Bail	B3432
2-Hand Anti-Tiedown	Part No.
E23 Tools	20G100104
EA Tools	Add TH
Handle Options	Part No.
E2/3/4/5 Rubber Grip	20H207207
EA2/3 Front Facing Lever	20H100008
E2/3 Front Facing Lever	20H100005
Reaction Devices	Part No.
Reaction Bar	20K100000
Mounting Flange	20K100300
Base Mount Bracket	20K100500
Other Options	Part No.
See Page 176 for Crowfoot Vinyl Cover Options	
See Page 151 for Crowfoot Socket Selection	

Vertical Crowfoot Lever Tools (2.2 to 690 Nm)

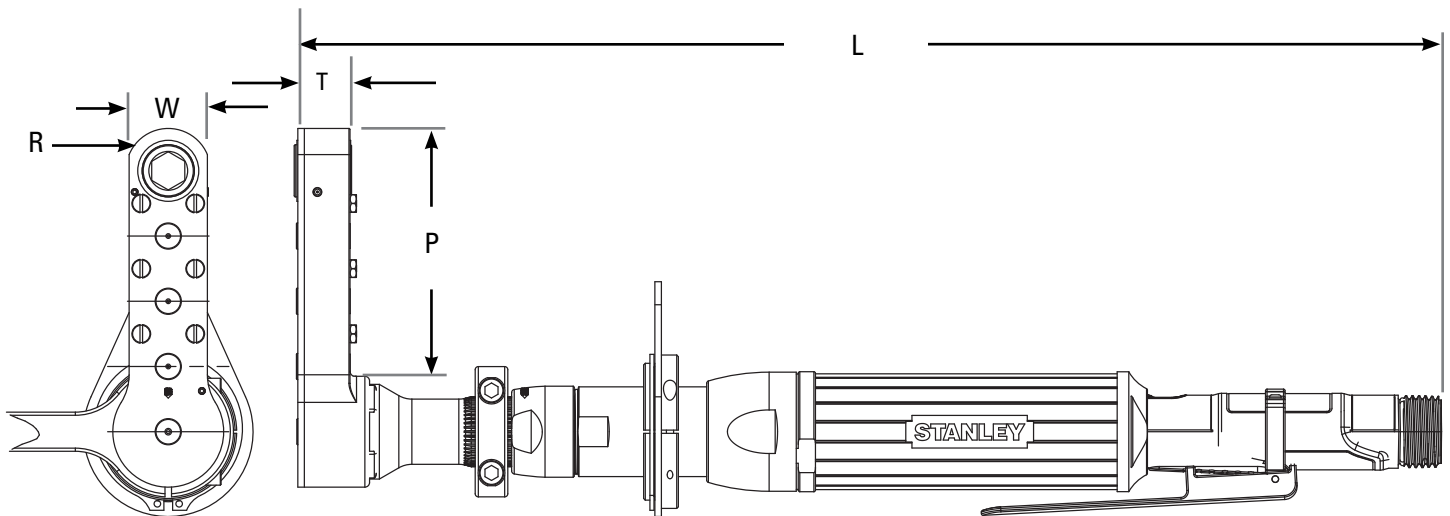
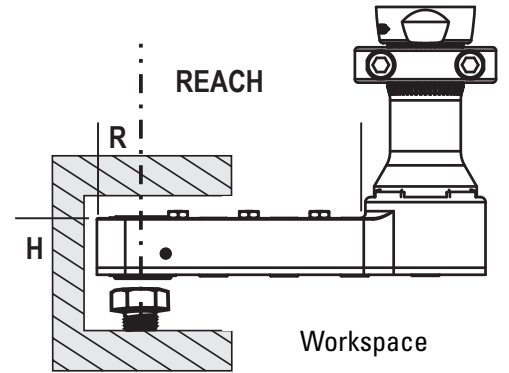

Model	Rated Speed	Torque		"R" Nose Radius		"T" Thickness		"W" Width		"P" Length		"L" Length		Weight		Maximum Hex Size	
	RPM	Nm	lb ft	mm	in	mm	in	mm	in	mm	in	mm	in	kg	lb	mm	in
E23LC278-15	785	15	11	21	0.81	14	0.55	38	1.50	170	6.70	533	21.0	4.9	10.9	19	3/4"
E33LC82-24	995	24	17.7	13	0.53	14	0.57	32	1.25	47	1.86	454	17.9	4.9	10.9	13	1/2"
E33LC152-28	890	28	20.7	21	0.81	14	0.55	38	1.50	75	2.95	489	19.3	4.9	10.9	19	3/4"
E34LC299-42	605	42	31.0	21	0.81	21	0.84	38	1.50	64	2.51	531	20.9	4.9	10.9	19	3/4"
E34LC552-42	605	42	31.0	21	0.81	21	0.84	38	1.50	64	2.51	685	27.0	3.4	7.5	19	3/4"
E34LC298-48	530	48	35.4	13	0.52	21	0.82	38	1.50	97	3.82	543	21.4	4.9	10.9	13	1/2"
E34LC353-50	490	50	36.9	21	0.81	21	0.84	38	1.50	43	1.70	535	21.1	4.9	10.9	19	3/4"
E45LC298-62	500	62	45.7	13	0.52	21	0.82	38	1.50	97	3.82	596	23.5	4.9	10.9	13	1/2"
E44LC83-70	585	70	51.6	21	0.81	28	1.10	38	1.50	102	4.03	558	22.0	4.9	10.9	19	3/4"
E45LC416-210	180	210	155	29	1.16	31	1.22	59	2.31	102	4.03	593	23.3	4.9	10.9	27	1-1/8"
E55LC468-350	140	350	258	25	0.98	47	1.87	95	3.75	147	5.78	911	35.9	4.9	10.9	24	15/16"
E55LC447-600	70	600	443	35	1.38	42	1.67	70	2.76	152	6.00	974	38.3	4.9	10.9	41	1-5/8"
E55LC345-615	90	615	454	41	1.63	42	1.67	78	3.06	88	3.45	909	35.8	4.9	10.9	41	1-5/8"
E55LC428-690	50	690	509	41	1.63	42	1.67	78	3.06	152	6.00	909	35.8	4.9	10.9	41	1-5/8"

Pistol Crowfoot Tools (6 to 30 Nm)

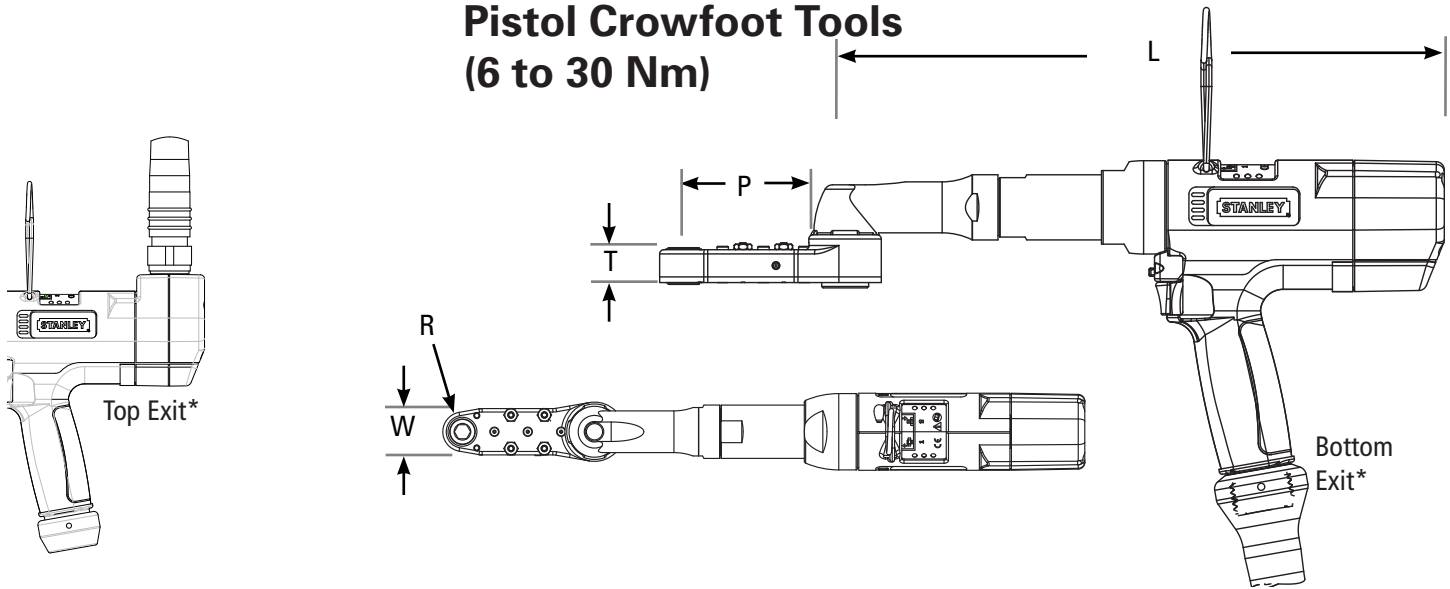

Model	Rated Speed		Torque		"R" Nose Radius		"T" Thickness		"W" Width		"P" Length		"L" Length		Weight		Maximum Hex Size	
	RPM	Nm	lb ft	mm	in	mm	in	mm	in	mm	in	mm	in	kg	lb	mm	in	
E33PC13-30	760	30	22.1	13	0.53	21	0.81	32	1.25	47	1.86	357	14	2.1	4.6	13	1/2"	
E33PC308-30	760	30	22.1	13	0.53	21	0.81	32	1.25	70	2.76	430	16.9	2.1	4.6	13	1/2"	
E33PC313-30	420	30	22.1	13	0.53	16	0.63	32	1.25	73	2.87	350	13.8	2.1	4.6	13	1/2"	
E33PC359-30	570	30	22.1	13	0.53	25	1.00	32	1.25	45	1.76	351	13.8	2.1	4.6	13	1/2"	
E33PC379-30	420	30	22.1	13	0.53	16	0.63	32	1.25	45	1.76	352	13.8	2.1	4.6	13	1/2"	

* Top Exit requires the use of a Fixtured tool whip cable while the Bottom Exit requires the use of a Handheld tool whip cable.

Inline Crowfoot Lever Tools (6 to 40 Nm)

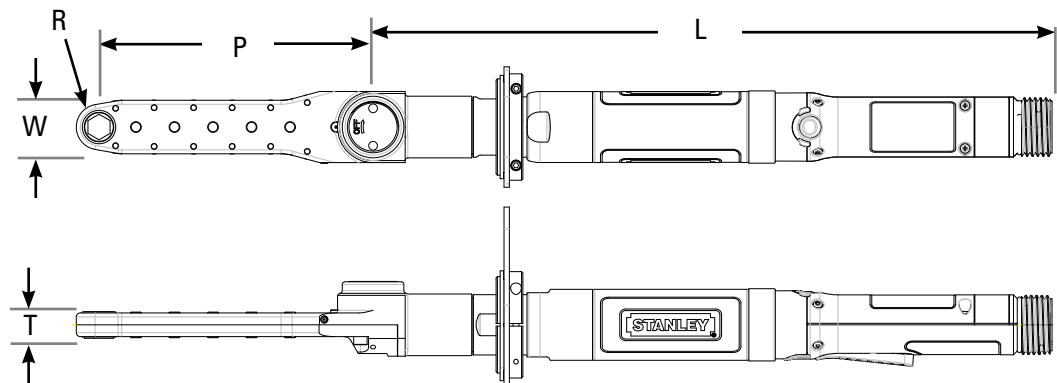

Model	Rated Speed		Torque		"R" Nose Radius		"T" Thickness		"W" Width		"P" Length		"L" Length		Weight		Maximum Hex Size	
	RPM	Nm	lb ft	mm	in	mm	in	mm	in	mm	in	mm	in	kg	lb	mm	in	
E12LC359-30	240	30	22.1	13	0.53	25	1.00	32	1.25	45	1.76	352	13.9	2.1	4.6	13	1/2"	
E12LC379-30	240	30	22.1	13	0.53	16	0.63	32	1.25	45	1.76	352	13.9	2.1	4.6	13	1/2"	
EA23LC379-30	410	30	22.1	13	0.53	16	0.63	32	1.25	45	1.76	461	18.1	2.1	4.6	13	1/2"	
EA33LC379-30	455	30	22.1	13	0.53	16	0.63	32	1.25	45	1.76	486	19.1	2.1	4.6	13	1/2"	
EA23LC487-30	410	30	22.1	13	0.53	16	0.63	32	1.25	136	5.36	566	22.3	2.1	4.6	13	1/2"	
EA33LC359-40	575	40	29.5	13	0.53	25	1.00	32	1.25	45	1.76	486	19.1	2.1	4.6	13	1/2"	

Angle Tubenut Lever Tools (2.8 to 22 Nm)

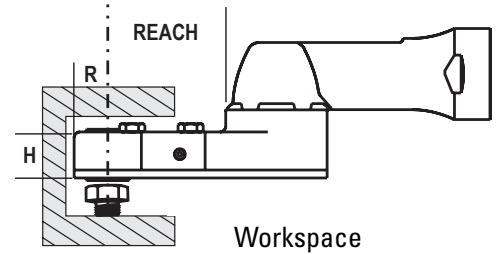

Angle Tubenut Options

Suspension Bails	Part No.
E12 Wire Bail	A3061
E12 Swivel Bail Assembly	20K101402
E23 Swivel Bail	20K101400
E23 Standard Wire Bail	B3432
2-Hand Anti-Tiedown	Part No.
E23 Tools	20G100104
Handle Options	Part No.
E12 Rubber Grip	20H207910
E12 Extended Lever Assembly	20H102201
E12 Heavy Duty Cable Adapter	20H103100
E2/3/4/5 Rubber Grip	20H207207
E2/3 Front Facing Lever	20H100005
Other Options	Part No.
E12 LED Flexible Light Kit	20K101804
E12 LED Stationary Light Kit	20S113202
See Page 176 for Tubenut Vinyl Cover Options	
See Page 151 for Tubenut Socket Selection	

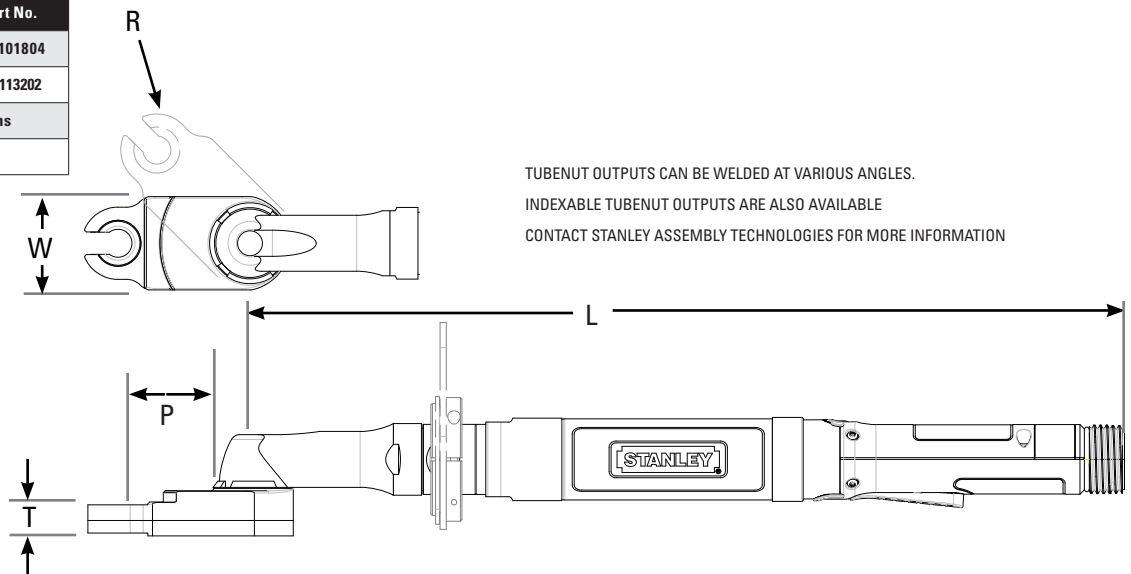

Model	Rated Speed		Torque		"R" Nose Radius		"T" Thickness		"W" Width		"P" Length		"L" Length		Weight		Maximum Hex Size		Maximum Tube Size	
	RPM	Nm	lb ft	mm	in	mm	in	mm	in	mm	in	mm	in	kg	lb	mm	in	mm	in	
E23LT74-14	750	14	10.3	18	0.73	14	0.56	48	1.88	44	1.72	532	20.9	2.5	5.4	18	11/16"	11.6	0.455	
E12LT224-15	595	15	11	13	0.51	13	0.52	32	1.26	50	1.97	364	14.3	2.5	5.4	11	7/16"	7.4	0.29	
E23LT280-15	500	15	11	13	0.51	13	0.52	32	1.26	50	1.97	560	22.0	2.5	5.4	11	7/16"	7.4	0.29	
E23LT224-20	500	20	14.8	13	0.51	13	0.52	32	1.26	50	1.97	517	20.3	2.5	5.4	11	7/16"	7.4	0.29	
E23LT282-20*	500	20	14.8	13	0.51	13	0.52	32	1.26	50	1.97	516	20.3	2.5	5.4	11	7/16"	7.4	0.29	
E23LT346-21	490	21	15.5	13	0.52	14	0.54	42	1.66	34	1.34	520	20.5	2.5	5.4	13	1/2"	9.3	0.365	
E23LT74-22	410	22	16.2	18	0.73	14	0.56	48	1.88	44	1.72	532	20.9	2.5	5.4	18	11/16"	11.6	0.455	

* Reverse Rotation

‡ Socket on Top

Check the symbols to ensure the correct tool is chosen for the application. Tubenuts are designed to be used with the socket on the bottom (base plate side) or on the top (angle head side) and in Clockwise or Counter-clockwise (Reverse) rotation. Tools without symbols have the socket on the bottom and run clockwise.

STANLEY Assembly Technologies has designed Tubenut and Crowfoot outputs for over 50 years. Contact STANLEY Assembly Technologies if you would like one designed for your specific application.

Angle Tubenut Lever Tools (5 to 102 Nm)

Angle Tubenut Options

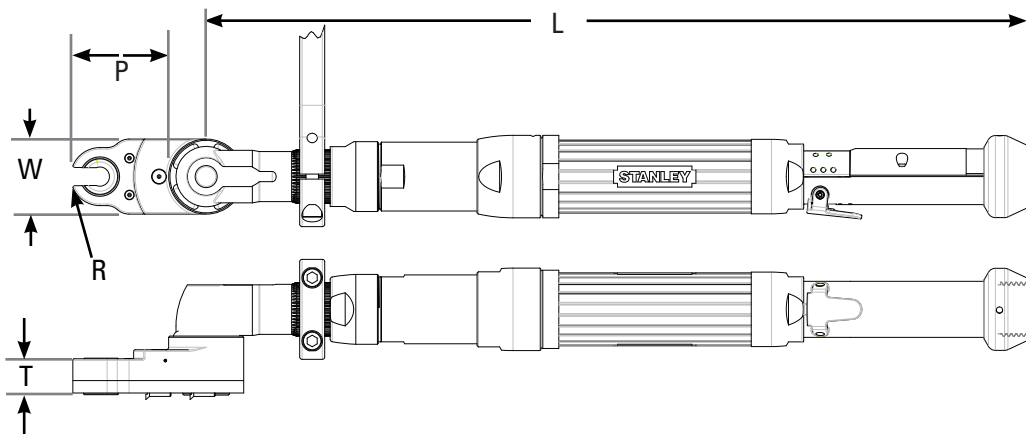

2-Hand Anti-Tiedown Switch		Part No.
E34/44/54 Tools		20K400001
EA Tools		Add TH
Suspension Bails ***		Part No.
Swivel (Horizontal)		20K200000
Standard (Vertical)		A3061
Reaction Devices		Part No.
Reaction Bar		20K100000
Mounting Flange		20K100300
Base Mount Bracket		20K100500
Handle Options		Part No.
EA3 Rubber Grip		20H207910
E2/3/4/5 Rubber Grip		20H207207
EA3 Front Facing Lever		20H100008
E3 Front Facing Lever		20H100005
E4/5 Front Facing Lever		20H100105
Motor Options		Part No.
E3 Tool Cooling Fan Kit		20M102600

Model	Rated Speed		Torque		"R" Nose Radius		"T" Thickness		"W" Width		"P" Length		"L" Length		Weight		Maximum Hex Size		Maximum Tube Size	
	RPM	Nm	lb ft	mm	in	mm	in	mm	in	mm	in	mm	in	kg	lb	mm	in	mm	in	
E33LT346-25	1050	25	18.4	13	0.52	14	0.54	42	1.66	34	1.34	545	21.5	2.3	5.1	13	1/2"	9.3	0.365	
EA33LT346-25	1105	25	18.4	13	0.52	14	0.54	42	1.66	34	1.34	511	20.1	4.8	10.6	13	1/2"	9.3	0.365	
E33LT349-25	1050	25	18.4	13	0.52	14	0.54	42	1.66	56	2.19	565	22.3	4.8	10.6	13	1/2"	9.3	0.365	
E33LT358-25*†	1050	25	18.4	13	0.52	14	0.54	42	1.66	34	1.34	545	21.5	2.3	5.1	13	1/2"	9.3	0.365	
EA33LT408-25 ^x	885	25	18.4	13	0.52	14	0.54	42	1.66	25	0.97	473	18.6	1.9	4.2	13	1/2"	9.3	0.365	
E33LT513-25	1050	25	18.4	13	0.52	14	0.54	42	1.66	56	2.19	565	22.3	4.8	10.6	13	1/2"	9.3	0.365	
E33LT74-30	765	30	22.1	18	0.73	14	0.56	48	1.88	44	1.72	557	21.9	2.6	5.7	18	11/16"	11.6	0.455	
EA33LT74-30	805	30	22.1	18	0.73	14	0.56	48	1.88	44	1.72	517	20.4	4.8	10.6	18	11/16"	11.6	0.455	
E33LT164-30*	765	30	22.1	18	0.73	14	0.56	48	1.88	47	1.86	557	21.9	4.8	10.6	18	11/16"	11.6	0.455	
E33LT527-30	750	30	22.1	18	0.73	16	0.63	48	1.88	16	0.64	528	21.1	4.8	10.6	19	3/4"	11.6	0.455	
E33LT368-41‡	365	41	30.2	13	0.52	21	0.85	44	1.72	59	2.33	574	22.6	4.8	10.6	13	1/2"	9.3	0.365	
E33LT375-41	365	41	30.2	13	0.52	21	0.85	44	1.72	59	2.33	573	22.5	4.8	10.6	13	1/2"	9.3	0.365	
E33LT549-41 ^x	365	41	30.2	13	0.52	21	0.85	44	1.72	59	2.33	574	22.6	4.8	10.6	13	1/2"	9.3	0.365	
E34LT23-41	495	41	30.2	18	0.73	23	0.91	48	1.88	44	1.72	590	23.3	3.6	7.9	18	11/16"	11.6	0.455	
EA34LT23-41	605	41	30.2	18	0.73	23	0.91	48	1.88	44	1.72	575	22.7	4.8	10.6	18	11/16"	11.6	0.455	
E34LT253-46*	515	46	33.9	26	1.04	16	0.64	75	2.94	65	2.55	598	23.6	4.8	10.6	27	1-1/16"	19.4	0.765	
E34LT99-46	430	46	33.9	26	1.04	19	0.77	75	2.94	65	2.55	598	23.6	3.9	8.6	27	1-1/16"	19.4	0.765	
E34LT99-62	385	62	45.7	26	1.04	19	0.77	75	2.94	65	2.55	620	24.4	3.9	8.6	27	1-1/16"	19.4	0.765	
EA34LT99A-62	400	62	45.7	26	1.04	19	0.77	75	2.94	65	2.55	604	24.8	4.8	10.6	27	1-1/16"	19.4	0.765	
E34LT116-62* †	385	62	45.7	26	1.04	19	0.77	75	2.94	65	2.55	598	23.6	4.8	10.6	27	1-1/16"	19.4	0.765	
EA34LT116A-62* †	400	62	45.7	26	1.04	19	0.77	75	2.94	65	2.55	604	23.8	4.8	10.6	27	1-1/16"	19.4	0.765	
E34LT99-67	285	67	49.4	26	1.04	19	0.77	75	2.94	65	2.55	620	24.4	4.8	10.6	27	1-1/16"	19.4	0.765	
E44LT20-102	375	102	75.2	26	1.04	32	1.25	75	2.94	65	2.55	604	24.8	4.8	10.6	27	1-1/16"	19.4	0.765	

* Reverse Rotation

† Socket on Top

^x Indexable Foot

Check the symbols to ensure the correct tool is chosen for the application. Tubenuts are designed to be used with the socket on the bottom (base plate side) or on the top (angle head side) and in Clockwise or Counter-clockwise (Reverse) rotation. Tools without symbols have the socket on the bottom and run clockwise.

STANLEY Assembly Technologies has designed Tubenut and Crowfoot outputs for over 50 years. Contact STANLEY Assembly Technologies if you would like one designed for your specific application.

Angle Extended Tubenut Lever Tools (5 to 62 Nm)

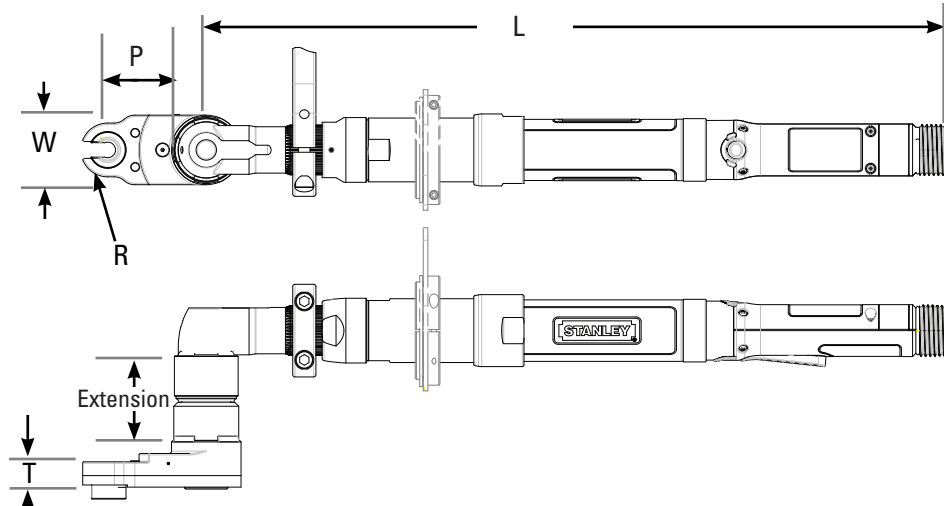

Model	Rated Speed		Torque		"R" Nose Radius		"T" Thickness		"W" Width		"P" Length		"L" Length		Weight		Maximum Hex Size		Maximum Tube Size	
	RPM	Nm	lb ft	mm	in	mm	in	mm	in	mm	in	mm	in	kg	lb	mm	in	mm	in	
E33LT288-25	670	25	18.4	13	0.52	9	0.34	42	1.66	16	0.63	508	20	2.5	5.4	13	1/2"	9.3	0.365	
E33LT387-25	1050	25	18.4	13	0.52	14	0.54	42	1.66	34	1.34	490	19.3	2.5	5.4	13	1/2"	9.3	0.365	
E33LT312-30	765	30	22.1	18	0.73	14	0.56	48	1.88	47	1.86	539	21.2	2.5	5.4	18	11/16"	11.6	0.455	
EA34LT361-41	605	41	30.2	19	0.73	16	0.63	48	1.88	44	1.72	574	24.4	2.5	5.4	19	3/4"	11.6	0.455	
E34LT283-62	385	62	45.7	26	1.04	19	0.77	75	2.94	65	2.55	557	21.9	2.5	5.4	27	1-1/16"	19.4	0.765	
E34LT296-62	385	62	45.7	26	1.04	19	0.77	75	2.94	65	2.55	620	24.4	2.5	5.4	27	1-1/16"	19.4	0.765	

Vertical Tubenut Lever Tools (5 to 30 Nm)

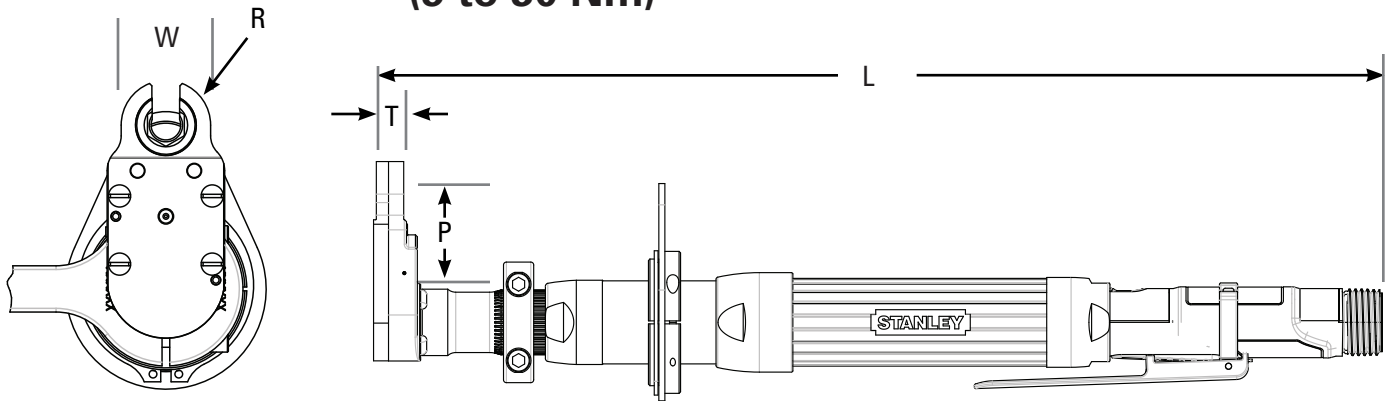

Model	Rated Speed		Torque		"R" Nose Radius		"T" Thickness		"W" Width		"P" Length		"L" Length		Weight		Maximum Hex Size		Maximum Tube Size	
	RPM	Nm	lb ft	mm	in	mm	in	mm	in	mm	in	mm	in	kg	lb	mm	in	mm	in	
E33LT540-25*†	1010	25	18.4	18	0.73	14	0.56	48	1.88	76	3.01	456	18	2.5	5.4	18	11/16"	11.6	0.455	
EA34LT150-30	940	30	22.1	18	0.73	14	0.56	48	1.88	47	1.86	515	20.3	2.5	5.4	19	3/4"	11.6	0.455	

* Reverse Rotation

† Socket on Top

× Indexable Foot

Check the symbols to ensure the correct tool is chosen for the application. Tubenuts are designed to be used with the socket on the bottom (base plate side) or on the top (angle head side) and in Clockwise or Counter-clockwise (Reverse) rotation. Tools without symbols have the socket on the bottom and run clockwise.

STANLEY Assembly Technologies has designed Tubenut and Crowfoot outputs for over 50 years. Contact STANLEY Assembly Technologies if you would like one designed for your specific application.

**Inline Tubenut Lever Tools
(4.4 to 45 Nm)**

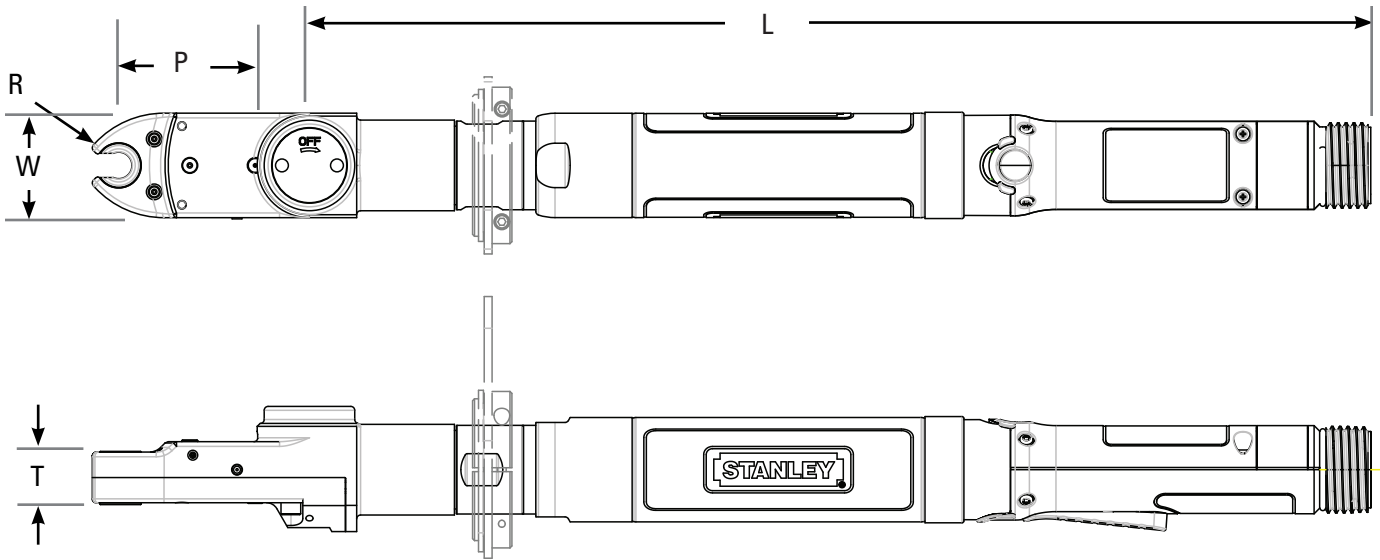

Model	Rated Speed		Torque		"R" Nose Radius		"T" Thickness		"W" Width		"P" Length		"L" Length		Weight		Maximum Hex Size		Maximum Tube Size	
	RPM	Nm	lb ft	mm	in	mm	in	mm	in	mm	in	mm	in	kg	lb	mm	in	mm	in	
E23LT264-22	480	22	16.2	21	0.84	18	0.70	54	2.13	77	3.03	502	19.8	2.0	4.4	24	15/16	18.2	0.718	
EA23LT264-22	675	22	16.2	21	0.84	18	0.70	54	2.13	77	3.03	507	20.0	1.8	4.0	24	15/16	18.2	0.718	
E33LT252-22	955	22	16.2	13	0.52	14	0.54	42	1.66	56	2.20	525	20.7	2.3	5.0	13	1/2	9.3	0.365	
EA33LT252-22	1300	22	16.2	13	0.52	14	0.54	42	1.66	56	2.20	510	20.1	2.1	4.6	13	1/2	9.3	0.365	
E12LT252-25	245	25	18.4	13	0.52	14	0.54	42	1.66	56	2.20	431	17.0	1.7	3.7	13	1/2	9.3	0.365	
E33LT252-25	955	25	18.4	13	0.52	14	0.54	42	1.66	56	2.20	525	20.7	2.4	5.3	13	1/2	9.3	0.365	
E33LT326-25	420	25	18.4	13	0.52	14	0.56	42	1.66	77	3.05	561	22.1	2.4	5.3	13	1/2	8.1	0.32	
EA33LT413-40	570	40	29.5	13	0.52	21	0.85	44	1.72	56	2.20	505	19.9	2.4	5.3	13	1/2	9.3	0.366	
E33LT264-44	545	44	32.5	21	0.84	18	0.70	54	2.13	77	3.03	548	21.6	2.1	4.7	24	15/16	18.2	0.718	
EA33LT264-44	740	44	32.5	21	0.84	18	0.70	54	2.13	77	3.03	533	21.0	2.4	5.3	24	15/16	18.2	0.718	
E23LT304-45*	215	45	33.2	21	0.84	18	0.70	54	2.13	77	3.03	538	21.2	2.4	5.3	24	15/16	18.2	0.718	

* Reverse Rotation

† Socket on Top

× Indexable Foot

Check the symbols to ensure the correct tool is chosen for the application. Tubenuts are designed to be used with the socket on the bottom (base plate side) or on the top (angle head side) and in Clockwise or Counter-clockwise (Reverse) rotation. Tools without symbols have the socket on the bottom and run clockwise.

STANLEY Assembly Technologies has designed Tubenut and Crowfoot outputs for over 50 years. Contact STANLEY Assembly Technologies if you would like one designed for your specific application.

E/ EA Series Hold and Drive Lever

Hold and Drive Lever Tools 1" Travel (7 to 380 Nm)

H&D Lever Tool Options

H18 Output	Part No.
Socket Options*	20D905700
1" Travel Bit Holder Output	20D124600
1" Travel Tang Holder Output	20D124602
2" Travel Bit Holder Output	20D124601
2" Travel Tang Holder Output	20D124603
H18 Tang Holder	Part No.
6mm x 8mm Rectangle	20D261700
5mm x 7.5mm Rectangle	20D261701
6mm x 10mm Rectangle	20D261702
6mm Hex *	20D261703
H18 Bit Holder	Part No.
1/4" Hex*	20D254200
5/16" Hex*	20D253400
H22 Output	Part No.
Socket Options*	~N4617
1" Travel Tang Holder Output	20D103211
1" Travel Bit Holder Output	20D103212
2" Travel Tang Holder Output	20D103213
2" Travel Bit Holder Output	20D103214
H22 Tang Holder	Part No.
Female Tang Holder Options	~F4287
H22 Bit Holder	Part No.
Bit Holder Options *	~F4288
H22 Reaction Bar	Part No.
Reaction Bar Assembly	20K100000
Mounting Flange Assembly	20K100300
Base Mount Bracket Assembly	20K100500
H26 Output	Part No.
Socket Options *	~F4285
1" Travel Tang Holder Output	20D103601
1" Travel Bit Holder Output	20D103602
2" Travel Tang Holder Output	20D103603
2" Travel Bit Holder Output	20D103604
H26 Tang Holder	Part No.
Female Tang Holder Options *	~H4948
H26 Bit Holder	Part No.
Bit Holder Options *	~H4947
H26 Reaction Bar	Part No.
Reaction Bar Assembly	20K100200
Mounting Flange Assembly	20K100700
Base Mount Bracket Assembly	20K100600
Reaction Bar Assembly, HD	20K100202

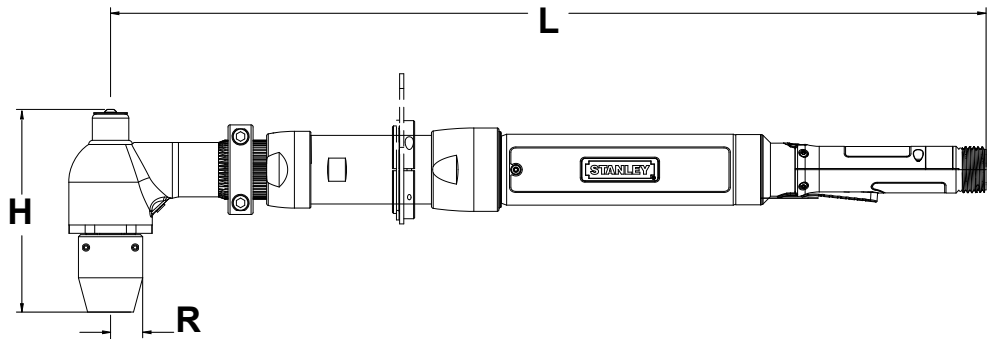

Model	Rated Speed	Torque		"R" Side to Center		"H" Head Height		"L" Length		Weight		Travel
	RPM	Nm	lb ft	mm	in	mm	in	mm	in	kg	lb	Standard
E23LH18V1-35	345	35	26	18	0.69	109	4.28	464	18.3	2	4.5	1" Tang
E33LH18V1-46	750	46	34	18	0.69	109	4.28	464	18.3	2.2	4.9	
EA33LH18V1-46	805	46	34	18	0.69	109	4.28	464	18.3	2	4.5	
E34LH22V1-66	535	66	49	22	0.88	118	4.65	530	20.9	3.4	7.5	
E34LN22V1-66	535	66	49	22	0.88	99	3.89	530	20.9	3.4	7.5	
E44LH22V1-66	535	66	49	22	0.88	118	4.65	539	21.2	3.8	8.4	
EA34LH22AV1-77	510	77	57	22	0.88	118	4.65	361	14.2	3.2	6.8	
EA34LN22AV1-77	510	77	57	22	0.88	99	3.89	361	14.2	3.2	6.8	
E55LH26V1-95	880	95	70	26	1.02	114	4.62	632	24.9	5.4	11.9	
E55LN26V1-95	880	95	70	26	1.02	96	3.8	632	24.9	5.4	11.9	
E34LH22AV1-110	300	110	81	22	0.88	118	4.65	361	14.2	3.4	7.5	
E34LN22AV1-110	300	110	81	22	0.88	99	3.89	361	14.2	3.4	7.5	
EA34LH22AV1-110	340	110	81	22	0.88	118	4.65	361	14.2	3.2	6.8	
EA34LN22AV1-110	340	110	81	22	0.88	99	3.89	361	14.2	3.2	6.8	
E44LH22AV1-110	480	110	81	22	0.88	118	4.65	539	21.2	3.8	8.4	
E44LN22AV1-110	480	110	81	22	0.88	99	3.89	539	21.2	3.8	8.4	
E45LH26V1-143	330	143	105	26	1.02	114	4.62	582	22.9	4.8	10.6	
E45LN26V1-143	330	143	105	26	1.02	96	3.8	582	22.9	4.8	10.6	
E45LH26V1-191	265	191	141	26	1.02	114	4.62	582	22.9	4.8	10.6	
E45LN26V1-191	265	191	141	26	1.02	96	3.8	582	22.9	4.8	10.6	
E55LH26V1-210	385	210	155	26	1.02	114	4.62	632	24.9	5.4	11.9	
E55LN26V1-210	385	210	155	26	1.02	96	3.8	632	24.9	5.4	11.9	
E55LH32V1-320	250	320	236	32	1.25	180	7.1	639	25.1	6.2	13.6	
E55LH32V1-380	200	380	280	32	1.25	180	7.1	639	25.1	6.2	13.6	

* Socket, Bit and Tang selections start on page 165

Hold and Drive Lever Tools 2" Travel
(7 to 380 Nm)

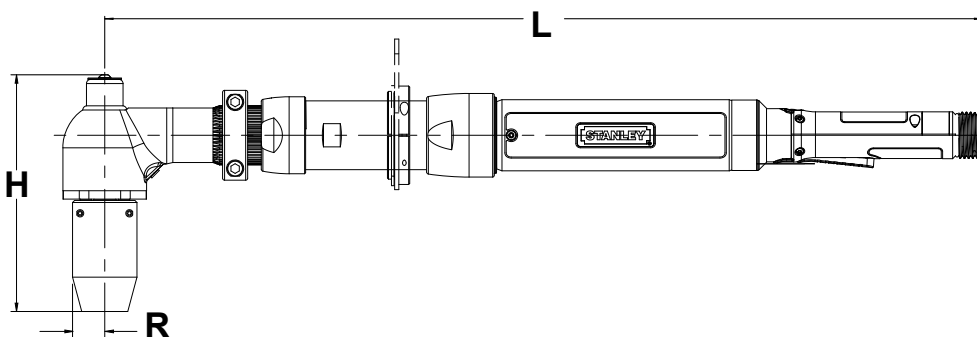

Model	Rated Speed		Torque		"R" Side to Center		"H" Head Height		"L" Length		Weight		Travel
	RPM	Nm	lb ft	mm	in	mm	in	mm	in	kg	lb	Standard	
E23LH18V2-35	345	35	26	18	0.69	109	4.28	464	18.3	2	4.5	2" Tang	
E33LH18V2-46	750	46	34	18	0.69	109	4.28	464	18.3	2.2	4.9		
EA33LH18V2-46	805	46	34	18	0.69	109	4.28	464	18.3	2	4.5		
E34LH22V2-66	535	66	49	22	0.88	118	4.65	530	20.9	3.4	7.5		
E44LH22V2-66	535	66	49	22	0.88	118	4.65	539	21.2	3.8	8.4		
EA34LH22AV2-77	510	77	57	22	0.88	118	4.65	361	14.2	3.2	6.8		
E55LH26V2-95	880	95	70	26	1.02	114	4.62	632	24.9	5.4	11.9		
E34LH22AV2-110	300	110	81	22	0.88	118	4.65	361	14.2	3.4	7.5		
EA34LH22AV2-110	340	110	81	22	0.88	118	4.65	361	14.2	3.2	6.8		
E44LH22AV2-110	480	110	81	22	0.88	118	4.65	539	21.2	3.8	8.4		
E45LH26V2-143	330	143	105	26	1.02	114	4.62	582	22.9	4.8	10.6		
E45LH26V2-191	265	191	141	26	1.02	114	4.62	582	22.9	4.8	10.6		
E55LH26V2-210	385	210	155	26	1.02	114	4.62	632	24.9	5.4	11.9		
E55LN26V2-210	385	210	155	26	1.02	96	3.8	632	24.9	5.4	11.9		
E55LH32V2-320	250	320	236	32	1.25	180	7.1	639	25.1	6.2	13.6		
E55LH32V2-380	200	380	280	32	1.25	180	7.1	639	25.1	6.2	13.6		

H&D Lever Tool Options continued

H32 Output	Part No.
Socket Options *	~A5302
1" Travel Tang Holder Output	20D103701
1" Travel Bit Holder Output	20D103702
2" Travel Tang Holder Output	20D103703
2" Travel Bit Holder Output	20D103704
H32 Tang Holder	Part No.
Female Tang Holder Options*	20D900601
H32 Bit Holder	Part No.
Bit Holder Options *	20D900602
H32 Reaction Bar	Part No.
Reaction Bar Assembly	20K100200
Mounting Flange Assembly	20K100700
Base Mount Bracket Assembly	20K100600
Reaction Bar Assembly, HD	20K100202

Hold & Drive Options

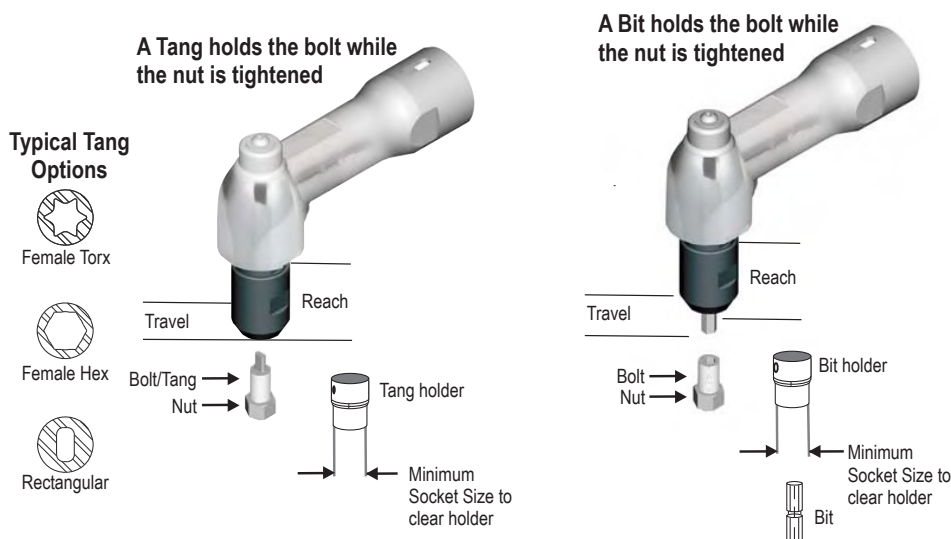

NOTE: The bolt can extend beyond the nut no more than the specified Travel distance when tightened.

E Series Fixtured Tools

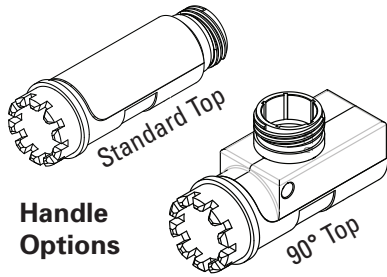

Handle Options

The E series Fixtured tool handle has been designed to include an optional cable connection that is perpendicular to the tool instead of at the end of the tool handle. This allows the tool to fit into tighter spaces. The handle itself can be rotated every 36°. With straight or 90° cables and this adjustable E series fixtured tool handle, optimal cable placement in the system is a snap.

All fixtured tools require a reaction device which can also be used as the mount to connect the tool to an arm or fixture. Choose one of the three types shown below when ordering the tool.

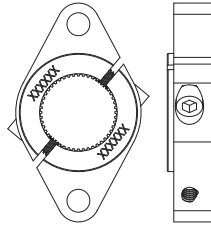

Optional Flange Mount Bracket

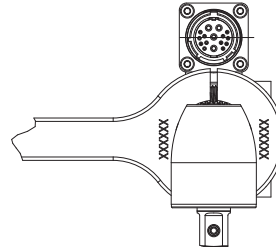

Standard Reaction Bar

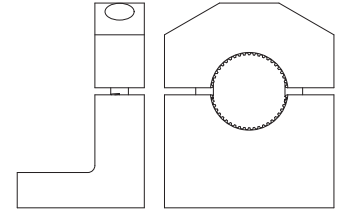

Optional Base Mount Bracket

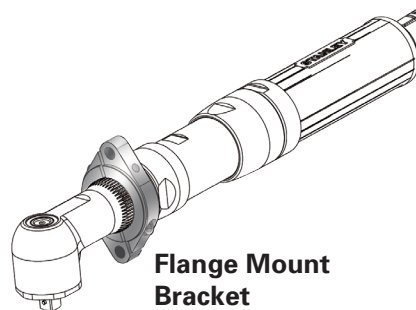

Flange Mount Bracket

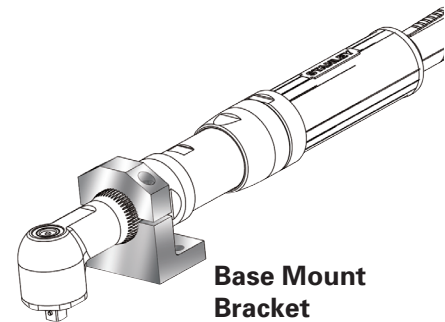

Base Mount Bracket

Steel reaction bars can be heated and bent or cut and welded to create a unique reaction device to fit specific applications.

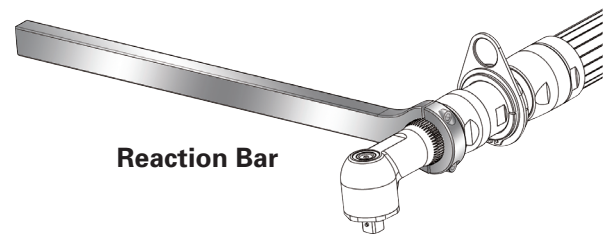

Reaction Bar

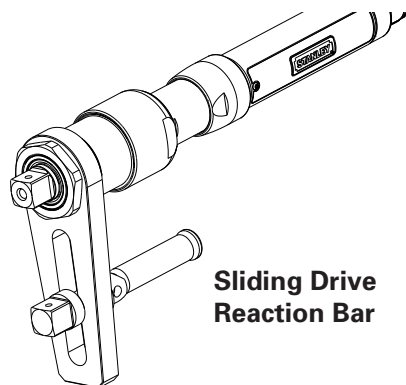

Sliding Drive Reaction Bar

Special sliding drive reaction bars can utilize a second fastener as the reaction absorber rather than the side of the product or a fixture or arm. This provides easy access to a reaction point without requiring a fixture or arm to absorb the reaction.

Angle Retractable Fixtured Tools (4.6 to 46 Nm)

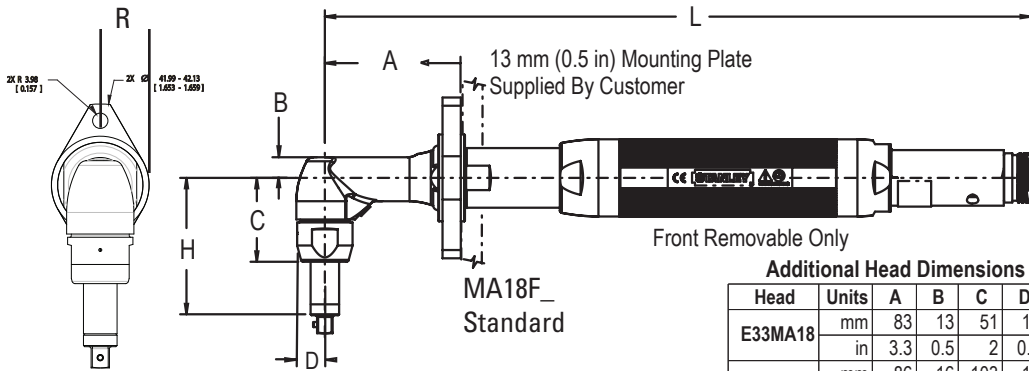

Additional Head Dimensions

Head	Units	A	B	C	D
E33MA18	mm	83	13	51	18
	in	3.3	0.5	2	0.7
E33MA19	mm	86	16	103	19
	in	3.4	0.6	4	0.8
E34MA19	mm	74	16	103	19
E44MA19	in	2.9	0.6	4	0.8
E34MA22	mm	82	16	130	22
E44MA22	in	3.2	0.6	5.1	0.9

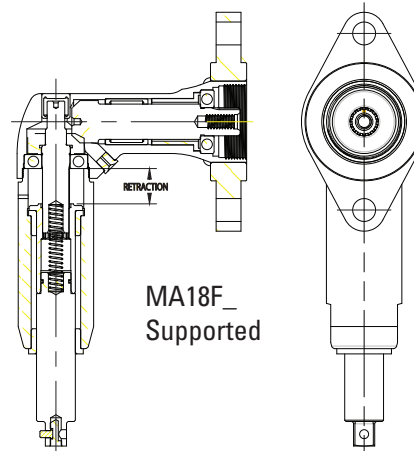
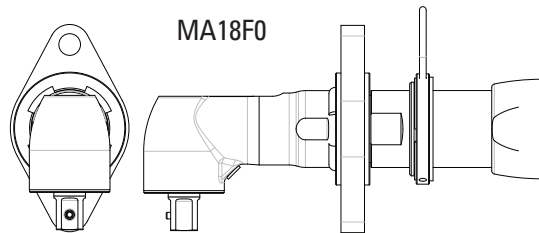

Options continued

Fixtured Handle	Part No.
Standard Top	20H202300
90° Top	20S105100
Socket Lock Pin 3/8" or 1/2" SD	Part No.
Standard	20D227800
Rounded (Ball Detent)	20D227801

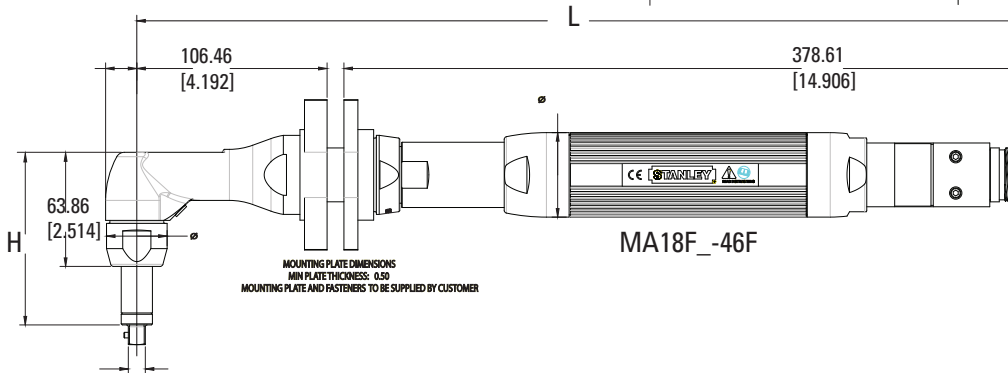

Model	Rated Speed	Torque		"R" Side to Center		"H" Head Height		"L" Length		Weight		Standard Output	
	RPM	Nm	lb ft	mm	in	mm	in	mm	in	kg	lb	Retraction	SD
E23MA18F0-23	660	23	17	28	1.1	39	1.6	408	16	2.2	4.9	N/A	3/8" SD
E33MA18F0-46	750	46	40	28	1.1	39	1.6	429	16.9	2.1	4.7		
E23MA18F1-23	660	23	17	28	1.1	97	3.8	408	16	2.6	5.7	16mm (5/8")	3/8" SD
E33MA18F1-46	750	46	40	28	1.1	97	3.8	433	17	2.5	5.6		
E33MA18F2-46	750	46	40	28	1.1	138	5.4	433	17	2.6	5.7	50mm (2")	3/8" SD
E33MA18F1-46F	750	46	40	28	1.1	97	3.8	495	19.5	2.8	6.1	25mm (1")	3/8" SD
E33MA18F2-46F	750	46	40	28	1.1	138	5.4	495	19.5	2.9	6.2	50mm (2")	3/8" SD

Angle Retractable Tool Options

MA18F0 Output	Part No.
3/8" Square Drive (SD)	20D104601
Flush Socket 16mm Max*	20D104608
3/8" - 24 Thread Female	20D104607
3/8" SD Flange 90° Rotated	20D104618
MA18F1 Output Standard	Part No.
3/8" Square Drive (SD)	20D104602 [‡]
3/8" SD Flange 90° Rotated	20D104611 [‡]
1/2" Square Drive (SD)	20D104604 [‡]
[‡] Pick one of these options for 20D104602, 20D104611	
3/8" Square Drive (SD)	M4265
3/8" SD X 1" Extension	20D118500
3/8" SD X 2" Extension	M4266
3/8" SD X 3" Extension	20D118501
3/8" SD X 4" Extension	20D118503
3/8" SD X 6" Extension	20D118502
3/8" SD X 7" Extension	20D118504
[‡] Pick one of these options for 20D104604	
1/2" Square Drive (SD)	M4289
1/2" SD X 2" Extension	M4290
MA18F1 Output Supported	Part No.
3/8" SD X 2" Extension	20D104603
1/2" SD X 2" Extension	20D104605
MA18F2 Output	Part No.
3/8" Square Drive (SD)	20D104609 [†]
3/8" SD Flange 90° Rotated	20D104622 [†]
[†] Pick one of these options for 20D104609, 20D104622	
3/8" Square Drive (SD)	20D111000
3/8" SD X 1/2" Extension	20D111002
3/8" SD X 55 mm Extension	20D111006
3/8" SD X 1" Extension	20D111003
3/8" SD X 2" Extension	20D111005
3/8" SD X 3 1/2" Extension	20S114200
3/8" SD X 4" Extension	20D111008
3/8" SD X 130 mm Extension	20D111010
3/8" SD X 6" Extension	20D111004
3/8" SD X 7" Extension	20D111001
MA18F1 Spring	Part No.
Standard (5.3 lbs)	M4270
Medium Duty (7.1 lbs)	M4886
Heavy Duty (12.3 lbs)	20R201429
MA18F2 Spring	Part No.
Standard (7.4 lbs)	20R201420
Medium Duty (10.2 lbs)	20R201421
Heavy Duty (36.7 lbs)	20R201430
E2 Motor	Part No.
Standard	20M200000
Without Wave Washer	20MS200000

*Flush socket selection starts on page 161

E Series Angle Retractable Fixtured

Angle Retractable Fixtured Tools (12 to 120 Nm)

Angle Retractable Tool Options

MA19F0 Threaded Output	Part No.
1/2" Square Drive (SD)	20D100002†
†Pick one of these options for 20D100002	
1/2" SD Lock Pin	20D227800
1/2" SD Ball Detent	20D227801
MA19F0 Splined Output	Part No.
1/2" Square Drive	20D100100*
*Pick one of these options for 20D100100	
1/2" SD Lock Pin	20D227800
1/2" SD Ball Detent	20D227801
1/2" Square Drive Anti-Vibration	20D100101
1/2" Double-Ended, Right Hand	20D100107
Flush Socket 17mm Max*	20D100106
MA19F1 Output	Part No.
1/2" Square Drive	20D115901
1/2" SD X 2" Extension	20D115901
MA19F2 Output	Part No.
1/2" Square Drive	20D112300
1/2" SD X 2" Extension	20D112301
MA22F1 Output	Part No.
1/2" SD	M4282
1/2" X 2" Extension	M4306
1/2" X 2-5/8" Extension	20D117700
1/2" X 8" Extension	M4466
MA19F1 Spring	Part No.
Standard (7.4 lbs)	A5313
Medium Duty (8.7 lbs)	20R201407
MA19F2 Spring	Part No.
Standard (7.4 lbs)	20R201420
Medium Duty (10.2 lbs)	20R201421
Heavy Duty (36.7 lbs)	20R201430
MA22F1 Spring	Part No.
Standard (3.1 lbs)	M4282
Medium Duty (5.8 lbs)	M4003
Heavy Duty (8.6 lbs)	M4800
MA22F2 Spring	Part No.
Standard (7.4 lbs)	20R201420
Medium Duty (10.2 lbs)	20R201421
Heavy Duty (36.7 lbs)	20R201430
Mounting Flange	Part No.
E34M	20K100300
E44M	20K100400
Fixtured Handle	Part No.
Standard Top	20H202300
90° Top	20S105100

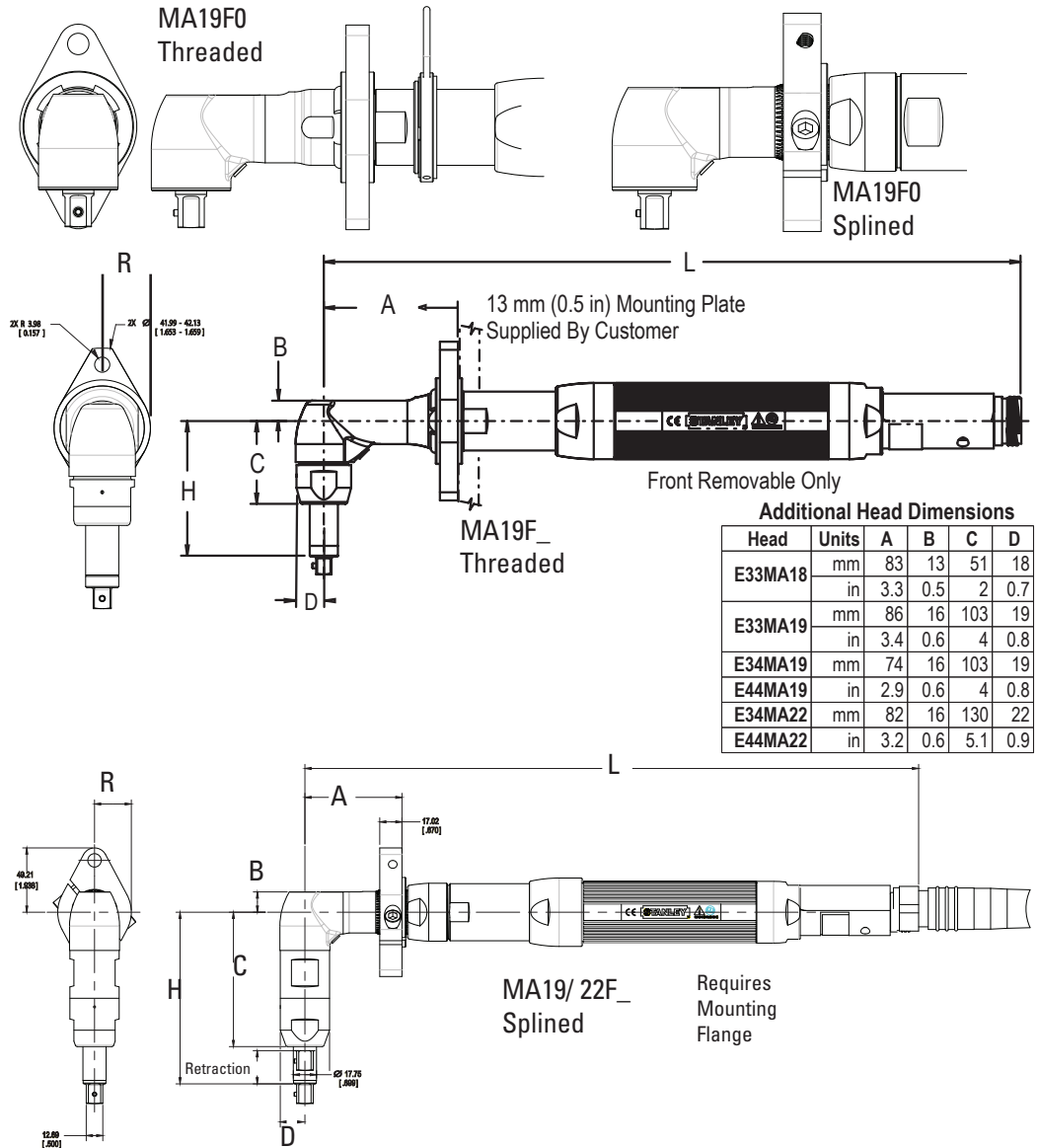

Model	Rated Speed		Torque		"R" Side to Center		"H" Head Height		"L" Length		Weight		Standard Output	
	RPM	Nm	lb ft	mm	in	mm	in	mm	in	kg	lb	Retraction	SD	
E33MA19F0-60	570	60	44.3	28	1.1	48	1.9	435	17.1	2.4	5.2	N/A	1/2" SD	
E34MA19F0-70	435	70	51.6	28	1.1	48	1.9	465	18.3	3	6.6			
E33MA19F1-60	570	60	44.3	28	1.1	147	5.8	440	17.3	2.7	6	25mm (1")	1/2" SD	
E44MA19F1-70	635	70	51.6	28	1.1	147	5.8	479	18.9	3.8	8			
E34MA19F1-70	435	70	51.6	28	1.1	147	5.8	470	18.5	3.4	7.6			
E44MA22F1-115	475	115	84.8	28	1.1	114	4.5	482	19	4.1	9			
E34MA22F1-115	295	115	84.8	28	1.1	114	4.5	473	18.6	3.7	8.2			
E44MA22F1-120	475	120	88.5	31	1.2	114	4.5	482	19	4.1	9			
E33MA19F2-60	570	60	44.3	28	1.1	194	7.6	440	17.3	2.8	6.1	50mm (2")	1/2" SD	
E44MA19F2-70	635	70	51.6	28	1.1	194	7.6	479	18.9	4.2	9.2			
E34MA19F2-70	435	70	51.6	28	1.1	194	7.6	470	18.5	3.5	7.8			
E34MA22F2-115	295	115	84.8	28	1.1	146	5.8	473	18.6	4.2	9.2			
E44MA22F2-120	475	120	88.5	31	1.2	146	5.8	482	19	4.2	9.3			

*Flush socket selection starts on page 161

Angle Retractable Fixtured Tools (20 to 401 Nm)

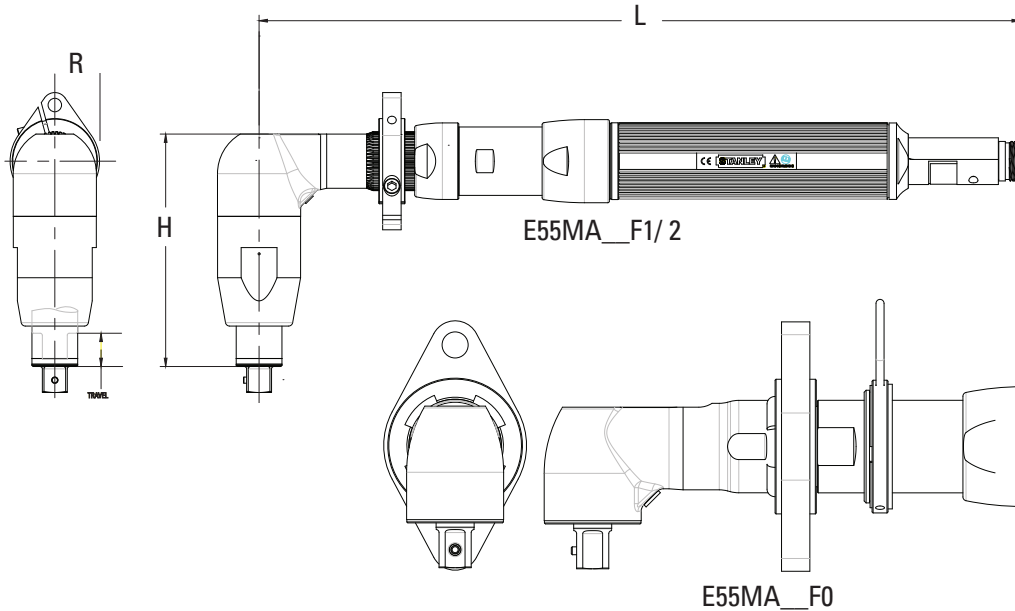

Angle Retractable Tool Options

MA26F0 Output >100 Nm	Part No.
5/8" Square Drive (SD)	20D100400
3/4" SD	20D100410
Flush Socket	20D100409
MA32F0 Output	Part No.
3/4" SD	20D102200
3/4" SD Ball Detent	20D104300
Hex Insert #	20D102204
Flush Socket 23mm Min	20D102201
MA26F1 Output	Part No.
5/8" SD	20D100402
1/2" SD 100 (NM Max)	20D100413
3/4" SD	20D100407
MA32F1 Output	Part No.
5/8" SD	M4600
5/8" X 4" Extension	M4610
3/4" SD	M4677
3/4" X 2-1/2" Extension	20D114800
3/4" X 4" Extension	M4740
MA26F2 Output	Part No.
5/8" SD	20D100405
1/2" SD 100 (NM Max)	20D100406
3/4" SD	20D100408
MA26F1 Spring	Part No.
Standard (5 lbs)	20R201414
Heavy Duty (11.5 lbs)	20R201417
MA26F2 Spring	Part No.
Standard (6.2 lbs)	20R201415
Heavy Duty (7.9 lbs)	20R201416
MA32F1 Spring	Part No.
Standard (9.7 lbs)	M4606
Heavy Duty (15 lbs)	M4331
MA32F2 Spring	Part No.
Standard (17.2 lbs)	20R201434
Heavy Duty (27 lbs)	20R201435
Mounting Flange	Part No.
MA26F / MA32F	20K100700
Fixtured Handle	Part No.
Standard Top	20H202300
90° Top	20S105100

#Inserts for 20D102204 A32 Hex Insert Output

Description	Part No.
1-1/8" Hex Socket Insert	A5172
30mm Hex Flush Socket Insert	20D222100
30mm with 3/4" Extension Flush Socket Insert	20D228900
1-1/16" Hex Socket Insert	20DS203600

The maximum hex size for the A32 Flush Socket Output is 27 mm (1-1/16").

Use the Hex Insert Output with these Inserts for larger hex sizes.

This will add 16.3 mm (0.64") to the "H" dimension of the tool.

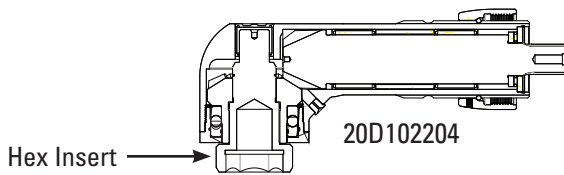

Model	Rated Speed		Torque		"R" Side to Center		"H" Head Height		"L" Length		Weight		Standard Output	
	RPM	Nm	lb ft	mm	in	mm	in	mm	in	kg	lb	Retraction	SD	
E55MA26F0-221	385	221	163	34	1.34	61	2.38	576	22.7	5.9	13	N/A	3/4" SD	
E55MA32F0-337	255	337	248	34	1.34	72.5	2.85	582	22.9	7.5	16.3			
E55MA32F0-401	205	401	295	34	1.34	72.5	2.85	582	22.9	7.5	16.3			
E55MA26F1-100	880	100	74	34	1.34	166	6.5	576	22.7	6.3	13.8	25mm (1")	3/4" SD	
E45MA26F1-150	330	150	110	34	1.34	166	6.5	525	20.7	5.7	12.5			
E55MA26F1-167	510	167	123	34	1.34	166	6.5	576	22.7	6.3	13.8			
E45MA26F1-201	265	201	148	34	1.34	166	6.5	525	20.7	5.7	12.5			
E55MA26F1-221	385	221	163	34	1.34	166	6.5	576	22.7	6.3	13.8			
E55MA32F1-337	255	337	248	34	1.34	178	7	582	22.9	7.7	16.8			
E55MA32F1-401	205	401	295	34	1.34	178	7	582	22.9	7.7	16.8			
E55MA26F2-100	880	100	74	34	1.34	166	6.5	576	22.7	6.4	14.1			50mm (2")
E45MA26F2-150	330	150	110	34	1.34	146	5.8	525	20.7	5.8	12.8			
E45MA26F2-201	265	201	148	34	1.34	146	5.8	576	22.7	6.4	14.1			
E55MA26F2-221	385	221	163	34	1.34	166	1.66	576	22.7	6.4	14.1			
E55MA32F2-337	255	337	248	34	1.34	268	10.6	582	22.9	7.8	17.1			

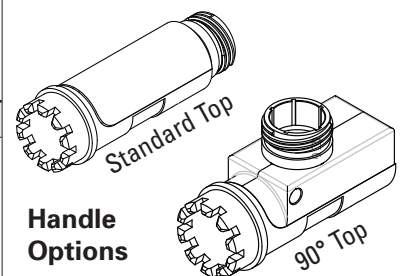

Handle Options

*Flush socket selection starts on page 161

E Series Inline Fixtured

Inline Tool Options - B

Output Options	Part No.
3/8" 24-Thread	20D100701
3/8" Square Drive	20D100600
3/8" Square Drive x 8" Extension	20D100702
1/4" Quick Change (17 Nm max)	20D101100
Lock Nut Options	Part No.
Lock Nut	F3697
Pinch Point	20D243501
Guided Collar	20D243502
Reaction Bar	Part No.
Reaction Bar, Aluminum (E23 only)	F3698
Reaction Bar, Steel	20K100100
Base Mount Bracket	A8606
Mounting Flange-B	20K101000
3/8" SD Socket Lock Pin	Part No.
Standard	20D227800
Rounded (Ball Detent)	20D227801
Suspension Bails***	Part No.
Wire Bail	A3061
Swivel	20K101400
Standard	B3432

*** Suspension bails on page 174

Inline Fixtured Tools (1.6 to 40 Nm)

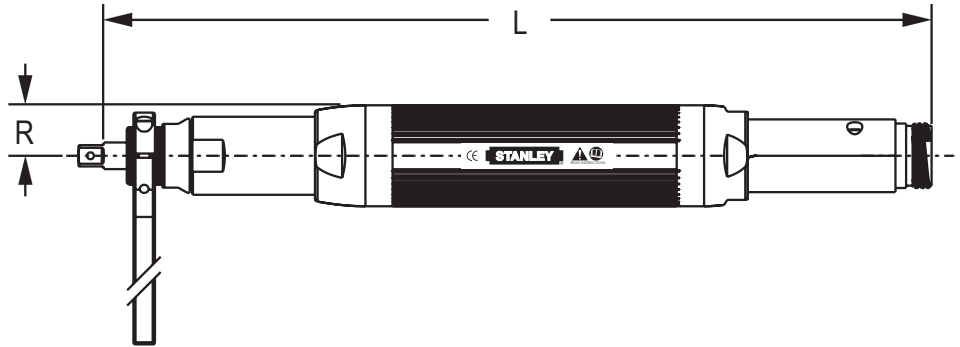

Model	Rated Speed		Torque		"R" Side to Center		"L" Length		Weight		Output	
	RPM	Nm	lb ft	mm	in	mm	in	kg	lb	Standard	Options	
E23MB-8	2245	8	6	24	0.93	344	13.6	1.4	3.1	3/8"	1/4" QC	
E23MB-16	2245	16	11.8	24	0.93	344	13.6	1.4	3.1			
E23MB-21	785	21	15.5	24	0.93	359	14.1	1.6	3.5		N/A	
E23MB-31	540	31	23	24	0.93	359	14.1	1.6	3.5			
E33MB-32	1125	32	24	24	0.93	385	15.1	1.7	3.8			
E33MB-40	890	40	30	24	0.93	385	15.1	1.7	3.8			

Inline Tool Options - B1

Output Options	Part No.
1/2" Square Drive x 6" Extension	20D101003
1/2" SD Socket Lock Pin	Part No.
Standard	K4024
Rounded (Ball Detent)	K4050
Reaction Components	Part No.
Reaction Bar	20K100000
Mounting Flange	20K100300
Base Mount Bracket	20K100500
Suspension Bail***	Part No.
Wire Bail	A3061
Swivel Bail	20K200000

*** Suspension bails on page 174

Inline Fixtured Tools (12 to 100 Nm)

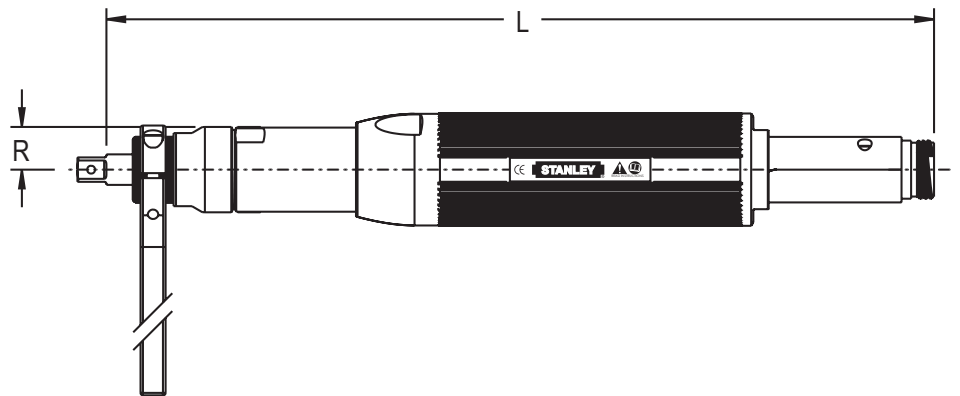

Model	Rated Speed		Torque		"R" Side to Center		"L" Length		Weight		Output
	RPM	Nm	lb ft	mm	in	mm	in	kg	lb	Standard	
E34MB1-60	605	60	44	32	1.25	421	16.6	2.6	5.7	1/2" SD	
E44MB1-66	885	66	49	32	1.25	430	16.9	2.9	6.4		
E34MB1-74	490	74	55	32	1.25	421	16.6	2.6	5.7		
E44MB1-100	590	100	74	32	1.25	430	16.9	2.9	6.4		
E34MB1-100	365	100	74	32	1.25	421	16.6	2.6	5.7		

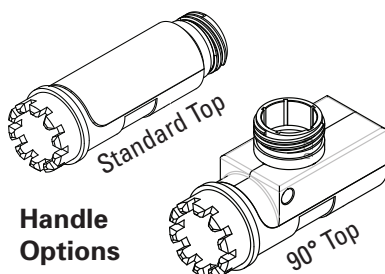

Inline Fixtured Tools
(25 to 250 Nm)

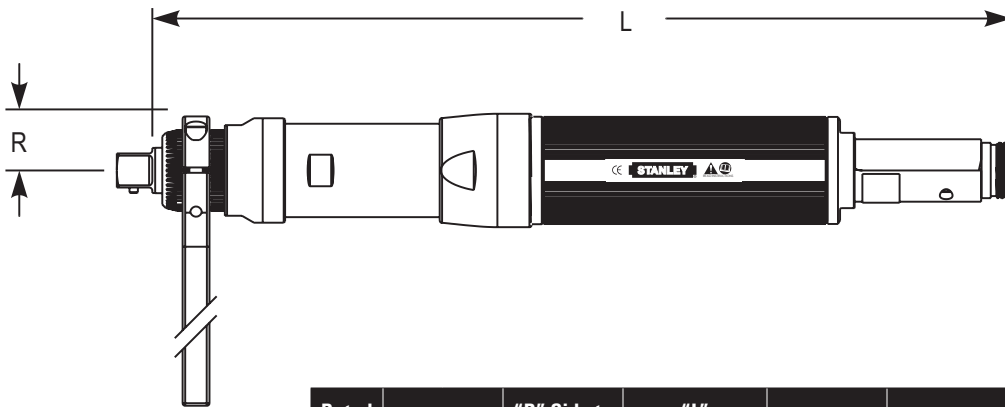

Model	Rated Speed		Torque		"R" Side to Center		"L" Length		Weight		Output
	RPM	Nm	lb ft	mm	in	mm	in	kg	lb	Standard	
E55MB2-127	720	127	94	34	1.35	503	19.8	4.7	10.3	3/4" SD	
E45MB2-160	345	160	118	34	1.35	475	18.7	4.4	9.6		
E55MB2-200	475	200	147	34	1.35	503	19.8	4.7	10.3		
E55MB2-250	380	250	184	34	1.35	503	19.8	4.7	10.3		
E45MB2-250	220	250	184	34	1.35	475	18.7	4.4	9.6		

Inline Tool Options - B2

Output Options	Part No.
5/8" Square Drive	20D102502
3/4" Square Drive x 8" Extension	20D102603
3/4" Square Drive x 12" Extension	20D102604
Socket Lock Pin	Part No.
Standard 3/4"	A5075
Standard 5/8"	A4026
Rounded (Ball Detent)	20R202300
Reaction Components	Part No.
Reaction Bar	20K100200
Reaction Bar - Heavy Duty	20K100202
Mounting Flange	20K100700
Base Mount Bracket	20K100600
Suspension Bail***	Part No.
Wire Bail	A3061
Swivel Bail	20K200100

*** Suspension bails on page 174

Inline Fixtured Tools
(64 to 2005 Nm)

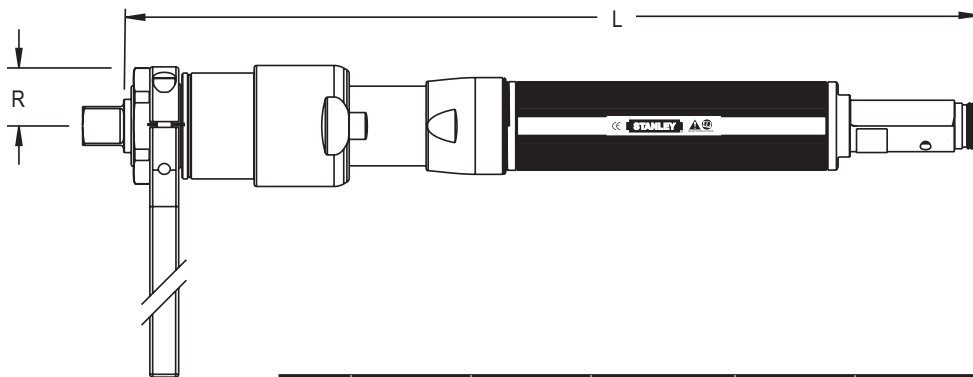

Model	Rated Speed		Torque		"R" Side to Center		"L" Length		Weight		Output
	RPM	Nm	lb ft	mm	in	mm	in	kg	lb	Standard	
E55MB3-322	230	322	237	32	1.25	573	22.5	5.3	11.5	3/4" SD	
E55MB4-471	185	471	347	44	1.7	621	24.4	7.4	16.3	1" SD	
E55MB4-623	140	623	459	44	1.7	621	24.4	7.4	16.3		
E55MB5-1023	75	1023	754	48	1.9	651	25.6	9.6	21.1		
E55MB5-1637	45	1637	1207	48	1.9	683	26.9	12	26.4		
E55MB5-2005	35	2005	1479	48	1.9	683	26.9	12	26.4		

Inline Tool Options - B3/ 4/ 5

Output Options	Part No.
B3 3/4" SD with Ball Retainer	20D104502
B4 1" SD with 1 1/2" Extension	20D208302
Lock Nut Options	Part No.
Lock Nut - B3	B4484
Reaction Components	Part No.
Reaction Bar - B3	B4487
Reaction Bar - B4, B5 <1500 Nm	F4192
Reaction Bar - B5 >1500 Nm	J4228
Base Mount Bracket - B3	H1140
Mounting Flange - B3	M4329
Mounting Flange - B4	20K101100
Mounting Flange - B5	20K100900
Socket Lock Pin	Part No.
Standard - B3	A5075
Rounded (Ball Detent) - 3/4", 1" SD	20R202300
Suspension Bails***	Part No.
Wire Bail	A3061
Swivel	20K200100

*** Suspension bails on page 174

E Series Crowfoot Fixtured

Angle Crowfoot Fixtured Tools (3.2 to 125 Nm)

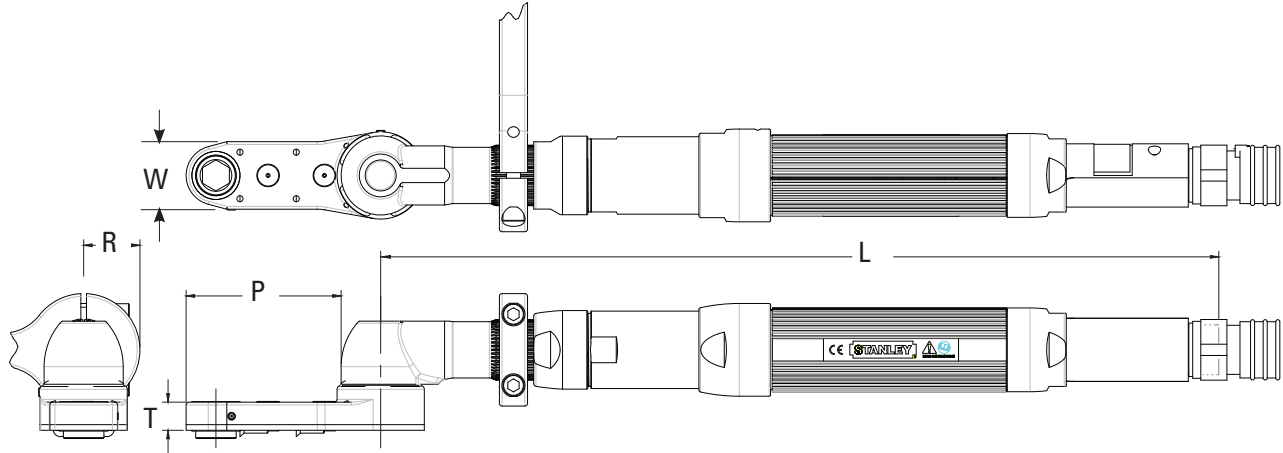

Model	Rated Speed		Torque		"R" Nose Radius		"T" Thickness		"W" Width		"P" Length		"L" Length		Weight		Maximum Hex Size	
	RPM	Nm	lb ft	mm	in	mm	in	mm	in	mm	in	mm	in	kg	lb	mm	in	
E23MC8-16	660	16	11.8	13	0.50	16	0.64	25	1	45	1.76	393	15.5	2.4	5.3	13	1/2"	
E34MC29-45	435	45	33.2	21	0.81	14	0.55	38	1.5	43	1.70	465	18.3	4.8	10.6	19	3/4"	
E34MC203-49	490	49	36.1	21	0.81	17	0.66	38	1.5	71	2.78	573	22.6	4.8	10.6	19	3/4"	
E34MC515-60	310	60	44.3	12	0.48	25	0.99	38	1.5	125	4.94	573	22.6	4.8	10.6	12	7/16"	
E34MC226-73	330	73	53.8	17	0.66	17	0.66	38	1.5	68	2.69	473	18.6	4.8	10.6	16	5/8"	
E45MC360-80	445	80	59	13	0.52	28	1.12	49	1.94	34	1.32	531	20.9	4.8	10.6	13	1/2"	
E45MC365-80	445	80	59	13	0.52	28	1.12	38	1.5	97	3.82	531	20.9	4.8	10.6	13	1/2"	
E44MC31-102	355	102	75.2	21	0.81	28	1.10	38	1.5	39	1.53	482	19	4.8	10.6	19	3/4"	
E45MC573-125	265	125	92.2	20	0.81	20	0.80	73	2.89	18	0.71	611	24	4.8	10.6	18	11/16"	

Vertical Crowfoot Fixtured Tools (12.4 to 77 Nm)

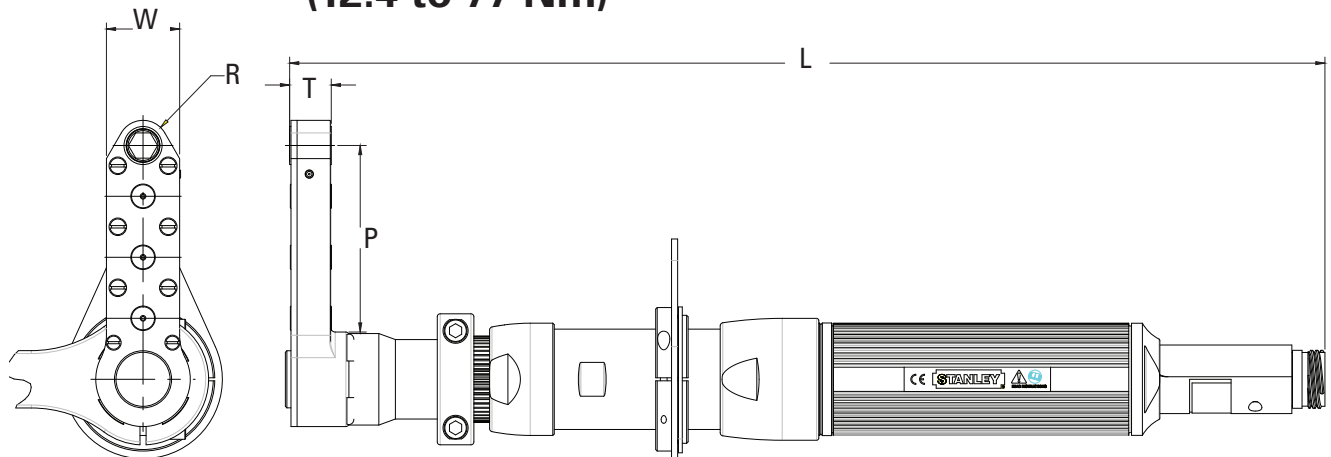

Model	Rated Speed		Torque		"R" Nose Radius		"T" Thickness		"W" Width		"P" Length		"L" Length		Weight		Maximum Hex Size	
	RPM	Nm	lb ft	mm	in	mm	in	mm	in	mm	in	mm	in	kg	lb	mm	in	
E45MC298-62	500	62	45.7	13	0.52	21	0.82	38	1.5	97	3.82	539	21.2	5.4	11.9	13	1/2"	
E45MC225-77	515	77	56.8	29	1.16	31	1.22	59	2.31	58	2.27	534	21	5.4	11.9	27	1-1/8"	

STANLEY Assembly Technologies has designed Tubenut and Crowfoot outputs for over 50 years. Contact STANLEY Assembly Technologies if you would like one designed for your specific application.

Hold and Drive Fixtured Tools (22 to 380 Nm)

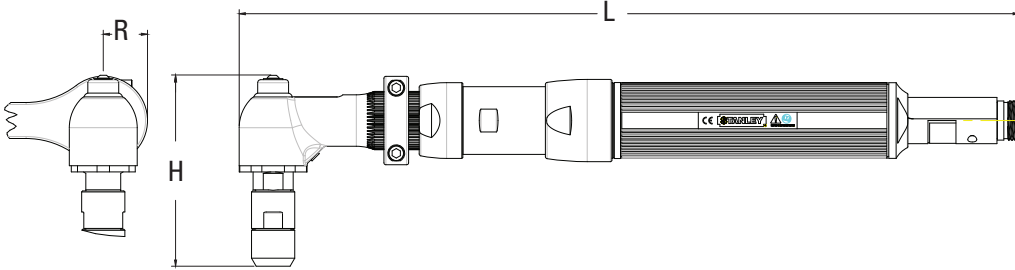

Model	Rated Speed		Torque		"R" Side to Center		"H" Head Height		"L" Length		Weight		Travel
	RPM	Nm	lb ft	mm	in	mm	in	mm	in	kg	lb	Standard	
E44MH22V1-110	300	110	81	22	0.88	118	4.65	361	14.2	3.4	7.5	1"	
E45MH26V2-143	330	143	105	26	1.02	114	4.62	582	22.9	4.8	10.6	2"	
E55MH26V2-210	385	210	155	26	1.02	114	4.62	632	24.9	5.4	11.9		
E55MH32V2-320	250	320	236	32	1.25	180	7.1	639	25.1	6.2	13.6		
E55MH32V2-380	200	380	280	32	1.25	180	7.1	639	25.1	6.2	13.6		

Hold & Drive Options

A Tang holds the bolt while the nut is tightened

Typical Tang Options

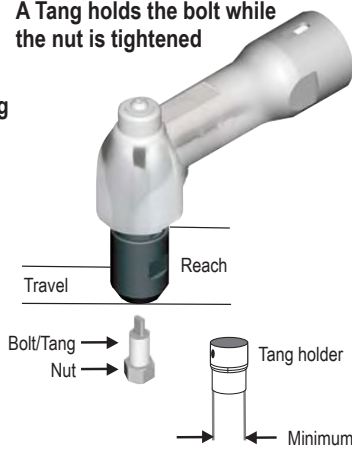

A Bit holds the bolt while the nut is tightened

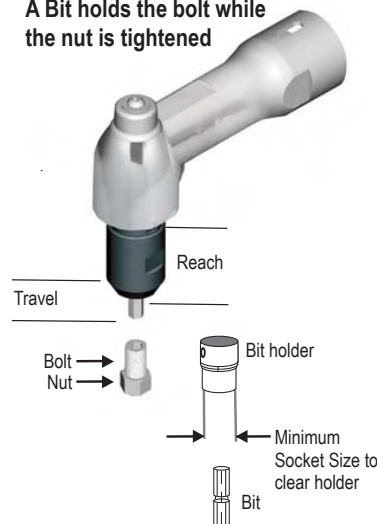

Typical Bit Options



Hold and Drive Options

H22 Output	Part No.
Socket Options*	~N4617
1" Travel Tang Holder Output	20D103211
1" Travel Bit Holder Output	20D103212
2" Travel Tang Holder Output	20D103213
2" Travel Bit Holder Output	20D103214
H22 Tang Holder	Part No.
Female Tang Holder Options	~F4287
H22 Bit Holder	Part No.
Bit Holder Options *	~F4288
H22 Reaction Bar	Part No.
Reaction Bar Assembly	20K100000
Mounting Flange Assembly	20K100300
Base Mount Bracket Assembly	20K100500
H26 Output	Part No.
Socket Options *	~F4285
1" Travel Tang Holder Output	20D103601
1" Travel Bit Holder Output	20D103602
2" Travel Tang Holder Output	20D103603
2" Travel Bit Holder Output	20D103604
H26 Tang Holder	Part No.
Female Tang Holder Options *	~H4948
H26 Bit Holder	Part No.
Bit Holder Options *	~H4947
H26 Reaction Bar	Part No.
Reaction Bar Assembly	20K100200
Mounting Flange Assembly	20K100700
Base Mount Bracket Assembly	20K100600
Reaction Bar Assembly, HD	20K100202
H32 Output	Part No.
Socket Options *	~A5302
2" Travel Tang Holder Output	20D103703
2" Travel Bit Holder Output	20D103704
H32 Tang Holder	Part No.
Female Tang Holder Options*	20D900601
H32 Bit Holder	Part No.
Bit Holder Options *	20D900602
H32 Reaction Bar	Part No.
Reaction Bar Assembly	20K100200
Mounting Flange Assembly	20K100700
Base Mount Bracket Assembly	20K100600
Reaction Bar Assembly, HD	20K100202

* Socket, Bit and Tang selections start on page 165

E Series Inline Retractable Fixtured

Inline Retractable Tool Options

MBF1 Output	Part No.
3/8" Square Drive (SD)	M3050
3/8" SD X 15/32" Extension	S3326
3/8" SD X 1.478" Extension	M3243
3/8" SD X 2" Extension	M3090
3/8" SD X 2 3/8" Extension	S3363
3/8" SD X 3" Extension	M3239
3/8" SD X 4" Extension	M3223
3/8" SD X 4 1/16" Extension	S3486
3/8" SD X 6" Extension	M3224
3/8" SD X 7 3/8" Extension	S3626
3/8" SD X 8" Extension	M3216
3/8" SD X 8" Extension, Thin	20S104600
3/8" - 24 Threaded	M3118
3/8" - 24 Threaded X 3/4" Long	M3227
MBF2 Output	Part No.
3/8" SD	M3282
3/8" SD X 1" Extension	20D209805
3/8" SD X 2" Extension	20D209807
3/8" SD X 3" Extension	20D209801
3/8" SD X 6" Extension	M3283
MBF1 Spring	Part No.
Standard	M4096
Medium Duty	M4126
Heavy Duty	M3184
Extra Heavy Duty	20R201428
MBF2 Spring	Part No.
Standard	M3289
Heavy Duty	M3306
Extra Heavy Duty	20D126900
Fixtured Handle	Part No.
Standard Top	20H202300
90° Top	20S105100
E2 Motor	Part No.
Standard	20M200000
Without Wave Washer	20MS200000
G3 Gear Case	Part No.
2-Handed Anti-Tiedown	20G100012
3/8" Socket Retainer	Part No.
Lock Pin	A4040
Ball Pin	A4232
Lock Pin Plug	A4041

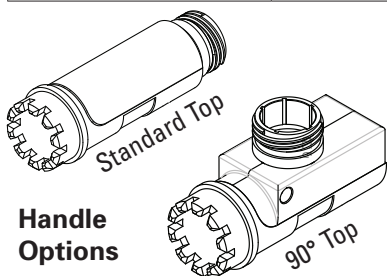

Inline Retractable Fixtured Tools (1.6 to 40 Nm)

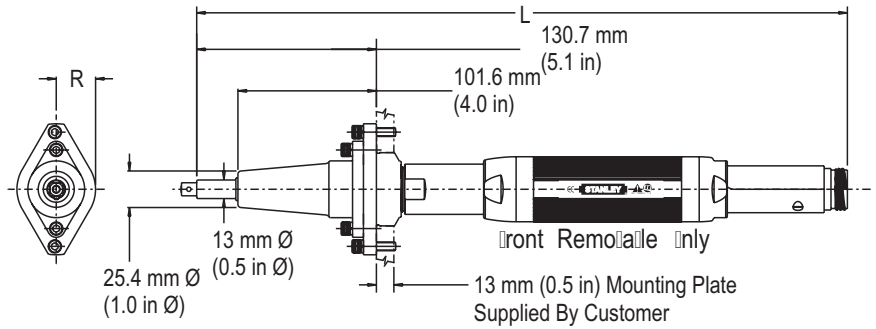

Model	Rated Speed	Torque		"R" Side to Center		"L" Length		Weight		Standard Output	
	RPM	Nm	lb ft	mm	in	mm	in	kg	lb	Retraction	SD
E23MBF1-8	2245	8	6	29	1.13	457	18	2.1	4.6	19 mm (3/4")	3/8"
E23MBF1-16	2245	16	11.8	29	1.13	470	18.5	2.3	5		
E23MBF1-21	785	21	15.5	29	1.13	470	18.5	2.3	5		
E23MBF1-31	540	31	23	29	1.13	470	18.5	2.3	5		
E33MBF1-32	1125	32	24	29	1.13	495	19.5	2.4	5.3		
E33MBF1-40	890	40	30	29	1.13	495	19.5	2.4	5.3		
E23MBF2-8	2245	8	6	29	1.13	547	21.5	2.2	4.8	50 mm (2")	3/8"
E23MBF2-21	785	21	15.5	29	1.13	561	22.1	2.4	5.3		
E23MBF2-31	540	31	23	29	1.13	561	22.1	2.4	5.3		
E33MBF2-32	1125	32	24	29	1.13	587	23.1	2.5	5.6		
E33MBF2-40	890	40	30	29	1.13	587	23.1	2.5	5.6		

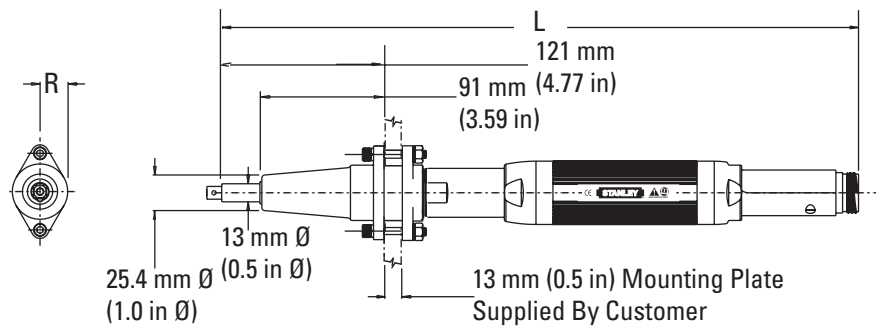

Model	Rated Speed	Torque		"R" Side to Center		"L" Length		Weight		Standard Output	
	RPM	Nm	lb ft	mm	in	mm	in	kg	lb	Retraction	SD
E23MBF1-8F	2245	8	6	23.6	0.93	457	18	2.1	4.6	19 mm (3/4")	3/8"
E23MBF1-16F	2245	16	11.8	23.6	0.93	470	18.5	2.3	5		
E23MBF1-21F	785	21	15.5	23.6	0.93	470	18.5	2.3	5		
E23MBF1-31F	540	31	23	23.6	0.93	470	18.5	2.3	5		
E33MBF1-32F	1125	32	24	23.6	0.93	495	19.5	2.4	5.3		
E33MBF1-40F	890	40	30	23.6	0.93	495	19.5	2.4	5.3		
E23MBF2-8F	2245	8	6	23.6	0.93	547	21.5	2.2	4.8	50 mm (2")	3/8"
E23MBF2-21F	785	21	15.5	23.6	0.93	561	22.1	2.4	5.3		
E23MBF2-31F	540	31	23	23.6	0.93	561	22.1	2.4	5.3		
E33MBF2-32F	1125	32	24	23.6	0.93	587	23.1	2.5	5.6		
E33MBF2-40F	890	40	30	23.6	0.93	587	23.1	2.5	5.6		

Inline Retractable Fixtured Tools (12 to 100 Nm)

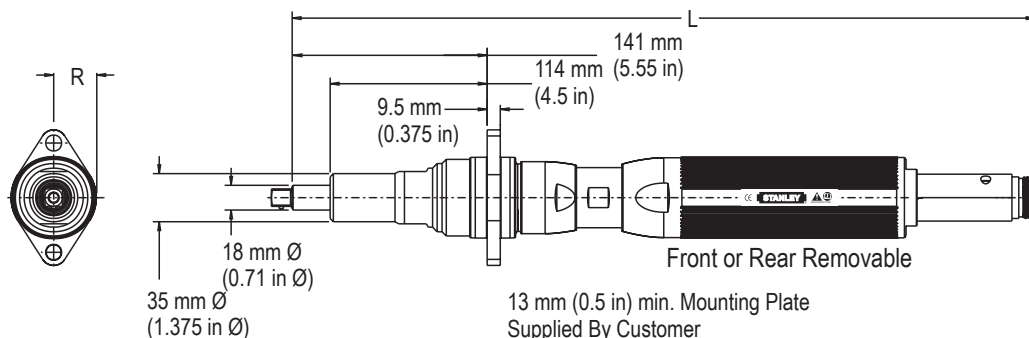

Model	Rated Speed		Torque		"R" Side to Center		"L" Length		Weight		Standard Output	
	RPM	Nm	lb ft	mm	in	mm	in	kg	lb	Retraction	SD	
E34MB1F1-60	605	60	44	28	1.1	531	20.9	3.5	7.7	25 mm (1")	1/2"	
E44MB1F1-66	885	66	49	31	1.2	540	21.3	4	8.9			
E34MB1F1-74	490	74	55	28	1.1	531	20.9	3.5	7.7			
E34MB1F1-100	365	100	74	28	1.1	531	20.9	3.5	7.7			
E44MB1F1-100	590	100	74	31	1.2	540	21.3	4	8.9			
E34MB1F2-60	605	60	44	28	1.1	616	24.3	3.5	7.7	50 mm (2")	1/2"	
E44MB1F2-66	885	66	49	31	1.2	625	24.6	4	8.9			
E34MB1F2-74	490	74	55	28	1.1	616	24.3	3.5	7.7			
E34MB1F2-100	365	100	74	28	1.1	616	24.3	3.5	7.7			
E44MB1F2-100	590	100	74	31	1.2	625	24.6	4	8.9			

Inline Retractable Tool Options

MB1F1 Output	Part No.
1/2" Square Drive (SD)	20D101600
1/2" SD with Ball Retainer	20D101602
1/2" SD X 2" Extension	20D101610
1/2" SD X 3" Extension	20D101603
1/2" SD X 4" Extension	20D101608
1/2" SD X 5" Extension	20D101604
1/2" SD X 6" Extension	20D101606
1/2" SD X 7 5/16" Extension	20D101605
1/2" SD X 8" Extension	20D101609
1/2" SD X 11" Extension	20D101607
MB1F2 Output	Part No.
3/8" SD	M6128
3/8" SD X 1" Extension	20DS102100
3/8" SD X 3" Extension	A6125
1/2" SD	M4815
1/2" SD X 2" Extension	20D122000
1/2" SD X 3" Extension	M6011
1/2" SD X 5" Extension	M4888
MB1F1 Spring	Part No.
Standard	B4093
Heavy Duty	20R201401
MB1F2 Spring	Part No.
Standard	M4821
Heavy Duty	20R201402
Extra Heavy Duty	20D126700
Fixtured Handle	Part No.
Standard Top	20H202300
90° Top	20S105100
3/8" Socket Retainer	Part No.
Lock Pin	A4040
Ball Pin	A4232
Lock Pin Plug	A4041
1/2" Socket Retainer	Part No.
Lock Pin	K4024
Ball Pin	K4050
Lock Pin Plug	K4025

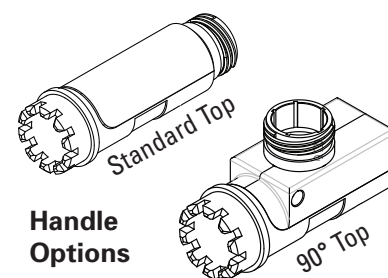

Inline Retractable Fixtured Tools (25.4 to 200 Nm)

Inline Retractable Tool Options

MB2F1 Output	Part No.
5/8" Square Drive (SD)	20D102901
5/8" SD X 2" Extension	20D102912
5/8" SD X 6" Extension	20D102913
MB2F2 Output	Part No.
5/8" Square Drive (SD)	20D102902
5/8" SD with Ball Retainer	20D102904
5/8" SD X 1 1/8" Extension	20D102906
5/8" SD X 1 1/8" Extension w/ Ball	20D102907
5/8" SD X 4" Extension	20D102903
5/8" SD X 4" Extension w/ Ball	20D102905
5/8" SD X 13 1/8" Extension	20D102908
5/8" SD X 13 1/8" Extension w/ Ball	20D102909
MB2F1 Spring	Part No.
Standard	20R201407
Heavy Duty	20D201408
MB2F2 Spring	Part No.
Light Duty	20R201423
Standard	20R201409
Heavy Duty	20R201410
Fixtured Handle	Part No.
Standard Top	20H202300
90° Top	20S105100
5/8" Socket Retainer	Part No.
Lock Pin	K4026
Ball Pin	20D227801
Lock Pin Plug	K4025
Compression Spring	20R201413
Pin Stop	L3401

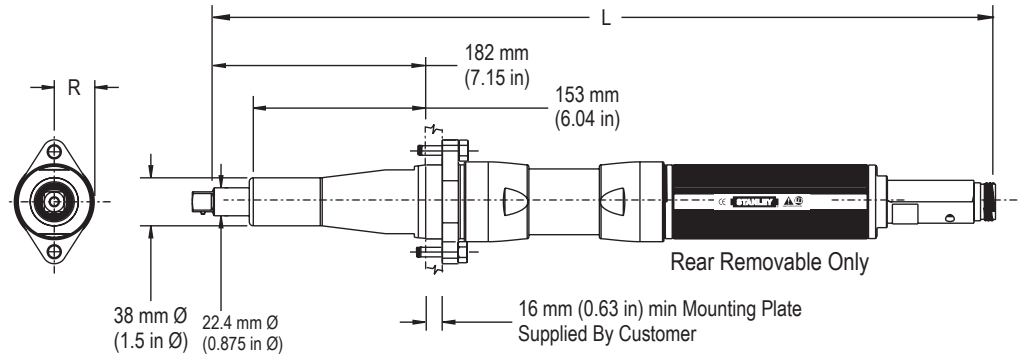

Model	Rated Speed		Torque		"R" Side to Center		"L" Length		Weight		Standard Output	
	RPM	Nm	lb ft	mm	in	mm	in	kg	lb	Retraction	SD	
E55MB2F1-127	715	127	94	32	1.25	649	25.6	6.2	13.7	25mm (1")	5/8"	
E45MB2F1-160	345	160	118	32	1.25	621	24.5	5.6	12.4			
E55MB2F1-200	475	200	147	32	1.25	649	25.6	6.2	13.7			
E55MB2F2-127	715	127	94	32	1.25	680	27.6	6.2	13.7	50mm (2")	5/8"	
E45MB2F2-160	345	160	118	32	1.25	672	26.5	5.6	12.4			
E55MB2F2-200	475	200	147	32	1.25	680	27.6	6.2	13.7			

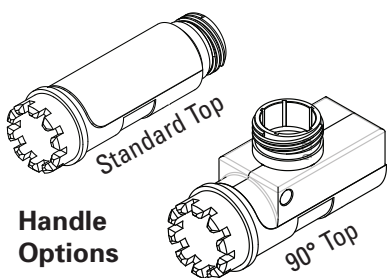

Handle Options

Inline Retractable Fixtured Tools (40 to 322 Nm)

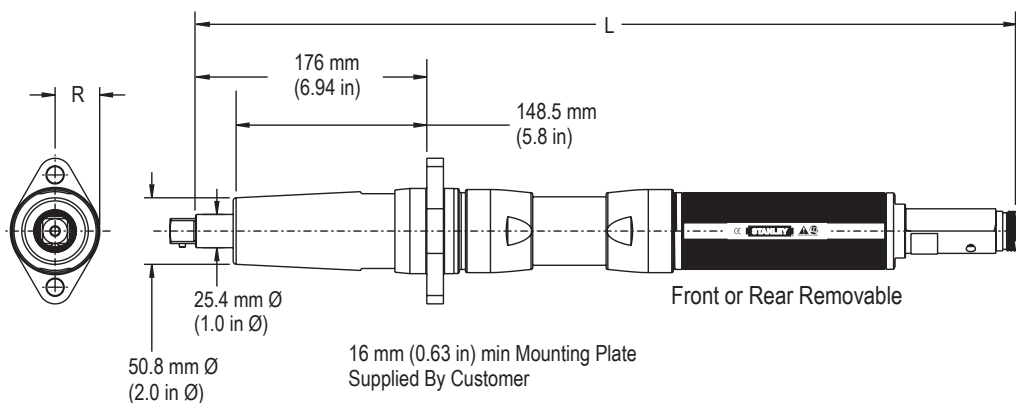

Inline Retractable Tool Options

MB3F1 Output	Part No.
3/4" Square Drive (SD)	20D102101
3/4" SD with Ball Retainer	20D102306
1/2" SD X 1.5" Extension	20D102106
MB3F2 Output	Part No.
3/4" Square Drive (SD)	20D102102
1/2" SD X 6" Extension	20D102105
MB3F1 Spring	Part No.
Standard	20R201403
Heavy Duty	20R201404
MB3F2 Spring	Part No.
Standard	20R201405
Heavy Duty	20R201406
Fixtured Handle	Part No.
Standard Top	20H202300
90° Top	20S105100
3/4" Socket Retainer	Part No.
Lock Pin	A5075
Ball Pin	20R202300
Lock Pin Plug	K4025
Reaction Components	Part No.
Mounting Flange -MB3F	20D205600

Model	Rated Speed		Torque		"R" Side to Center		"L" Length		Weight		Standard Output	
	RPM	Nm	lb ft	mm	in	mm	in	kg	lb	Retraction	SD	
E55MB3F1-200	475	200	147	34	1.34	656	25.8	7.7	17	25 mm (1")	3/4"	
E55MB3F1-250	380	250	184	34	1.34	656	25.8	7.7	17			
E45MB3F1-250	220	250	184	34	1.34	628	24.7	7.1	15.6			
E55MB3F1-322	230	322	237	34	1.34	734	28.9	11	24.4			
E55MB3F2-200	380	200	147	34	1.34	735	29	7.9	17.5	50 mm (2")	3/4"	
E55MB3F2-250	380	250	184	34	1.34	735	29	7.9	17.5			
E45MB3F2-250	220	250	184	34	1.34	707	27.9	7.3	16			
E55MB3F2-322	230	322	237	34	1.34	813	32	11.3	25			
E55MB3F3-322	230	322	237	34	1.34	813	32	11.3	25	75 mm (3")	3/4"	

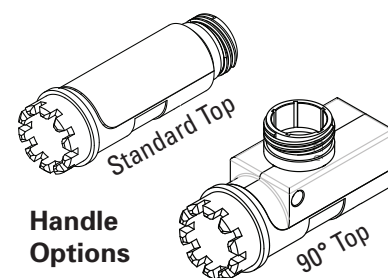

E Series Inline Retractable Fixtured

Inline Retractable Fixtured Tools (94 to 2005 Nm)

Inline Retractable Tool Options

MB4F1 Output	Part No.
3/4" Square Drive (SD)	20D121100
1" Square Drive with Ball Retainer	20D103503
MB4/5F1 Output	Part No.
1" Square Drive (SD)	20D208800
1" SD X 2" Extension	20D208803
1" SD X 4" Extension	20D208802
MB4/5F2 Output	Part No.
1" Square Drive (SD)	M5379
1" SD X 350 mm Extension	20D212500
1" SD X 2" Extension	20D212501
MB4/5F1 Spring	Part No.
Standard	20R201411
MB4/5F2 Spring	Part No.
Standard	M5382
Heavy Duty	20R206300
Fixtured Handle	Part No.
Standard Top	20H202300
90° Top	20S105100
1" Socket Retainer	Part No.
Ball Pin	20D202300
Reaction Components	Part No.
Mounting Flange - MB4F	20D208500
Mounting Flange - MB5F	20D209500

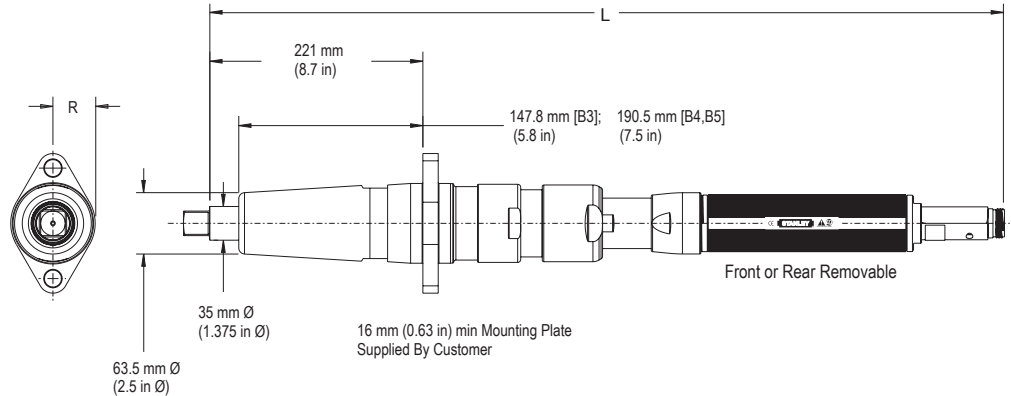

Model	Rated Speed		Torque		"R" Side to Center		"L" Length		Weight		Standard Output	
	RPM	Nm	lb ft	mm	in	mm	in	kg	lb	Retraction	SD	
E55MB4F1-471	185	471	347	44	1.7	814	32	17.2	38	25mm (1")	5/8"	
E55MB4F1-623	140	623	459	44	1.7	814	32	17.2	38			
E55MB5F1-800	90	800	590	48	1.9	859	33.8	18.3	40.2			
E55MB5F1-1023	75	1023	754	48	1.9	859	33.8	18.3	40.2			
E55MB5F1-1637	45	1637	1207	48	1.9	891	35	19.2	42.2			
E55MB5F1-2005	35	2005	1479	48	1.9	891	35	19.2	42.2			
E55MB4F2-471	185	471	347	44	1.7	928	36.5	17.5	38.5	50mm (2")	5/8"	
E55MB4F2-623	140	623	459	44	1.7	928	36.5	17.5	38.5			
E55MB5F2-1023	75	1023	754	48	1.9	964	37.9	18.6	41			
E55MB5F2-1637	45	1637	1207	48	1.9	996	39.1	19.5	43			

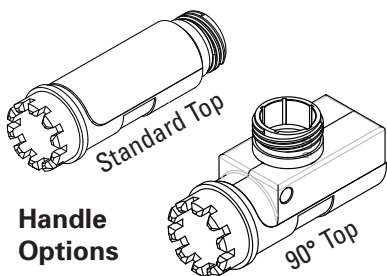

Handle Options

Offset Retractable Fixtured Tools (1.4 to 36 Nm)

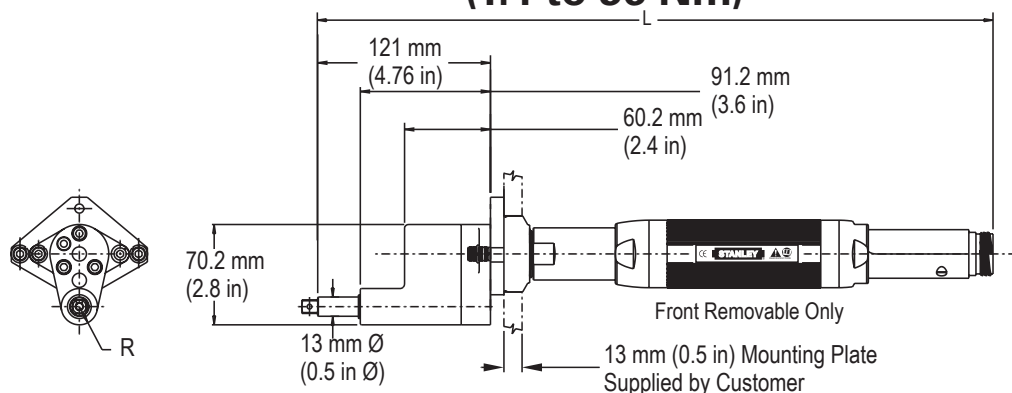

Model	Rated Speed		Torque		"R" Side to Center		"L" Length		Weight		Standard Output	
	RPM	Nm	lb ft	mm	in	mm	in	kg	lb	Retraction	SD	
E23MDF1-7	2245	7	5	13	0.5	457	18	2.4	5.2	19 mm (3/4")	3/8"	
E23MDF1-19	785	19	14	13	0.5	470	18.5	2.5	5.6			
E23MDF1-27	540	27	20	13	0.5	470	18.5	2.5	5.6			
E33MDF1-29	1125	29	21	13	0.5	496	19.5	2.7	5.9			
E33MDF1-36	890	36	27	13	0.5	496	19.5	2.7	5.9			
E23MDF2-7	2245	7	5	13	0.5	534	21	2.5	5.5	50 mm (2")	3/8"	
E23MDF2-19	785	19	14	13	0.5	549	21.6	2.6	5.9			
E23MDF2-27	540	27	20	13	0.5	549	21.6	2.6	5.9			
E33MDF2-29	1125	29	21	13	0.5	574	22.6	2.8	6.2			
E33MDF2-36	890	36	27	13	0.5	574	22.6	2.8	6.2			

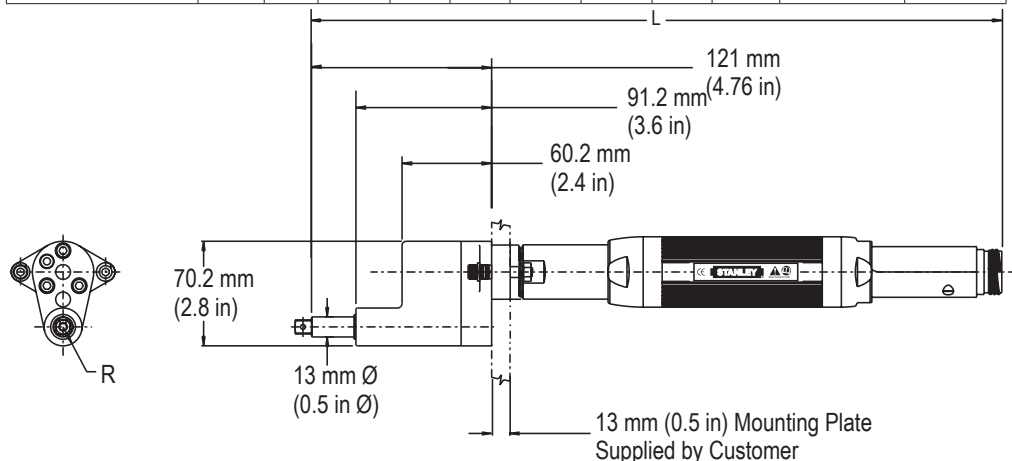

Model	Rated Speed		Torque		"R" Side to Center		"L" Length		Weight		Standard Output	
	RPM	Nm	lb ft	mm	in	mm	in	kg	lb	Retraction	SD	
E23MDF1-7F	2245	7	5	13	0.5	457	18	2.4	5.2	19 mm (3/4")	3/8"	
E23MDF1-19F	785	19	14	13	0.5	470	18.5	2.5	5.6			
E23MDF1-27F	540	27	20	13	0.5	470	18.5	2.5	5.6			
E33MDF1-29F	1125	29	21	13	0.5	496	19.5	2.7	5.9			
E33MDF1-36F	890	36	27	13	0.5	496	19.5	2.7	5.9			
E23MDF2-7F	2245	7	5	13	0.5	534	21	2.5	5.5	50 mm (2")	3/8"	
E23MDF2-19F	785	19	14	13	0.5	549	21.6	2.6	5.9			
E23MDF2-27F	540	27	20	13	0.5	549	21.6	2.6	5.9			
E33MDF2-29F	1125	29	21	13	0.5	574	22.6	2.8	6.2			
E33MDF2-36F	890	36	27	13	0.5	574	22.6	2.8	6.2			

Offset Retractable Tool Options

MDF1 Output	Part No.
3/8" Square Drive (SD)	M3050
3/8" SD X 1 5/32" Extension	S3362
3/8" SD X 1.478" Extension	M3243
3/8" SD X 2" Extension	M3090
3/8" SD X 2 3/8" Extension	S3363
3/8" SD X 3" Extension	M3239
3/8" SD X 4" Extension	M3223
3/8" SD X 4 1/16" Extension	S3486
3/8" SD X 6" Extension	M3224
3/8" SD X 7 3/8" Extension	S3626
3/8" SD X 8" Extension	M3216
3/8" SD X 8" Extension, Thin	20S104600
3/8" - 24 Thread	M3118
3/8" - 24 Thread X 3/8" Extension	M3227
MDF2 Output	Part No.
3/8" Square Drive (SD)	M3282
3/8" SD X 1" Extension	20D209805
3/8" SD X 2" Extension	20D209807
3/8" SD X 3" Extension	20D209801
3/8" SD X 6" Extension	M3283
MDF1 Spring	Part No.
Standard	M3062
Heavy Duty	M3183
MDF2 Spring	Part No.
Standard	M3289
Heavy Duty	M3306
Extra Heavy Duty	20D1126900
Fixtured Handle	Part No.
Standard Top	20H202300
90° Top	20S105100
E2 Motor	Part No.
Standard	20M200000
Without Wave Washer	20MS200000
3/8" Socket Retainer	Part No.
Lock Pin	A4040
Ball Pin	A4232
Lock Pin Plug	A4041

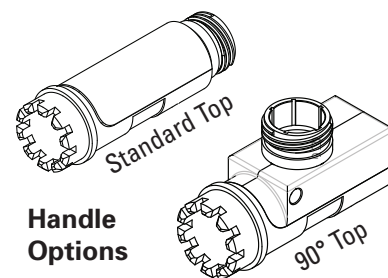

E Series Offset Retractable Fixtured

Offset Retractable Fixtured Tools (10.8 to 90 Nm)

Offset Retractable Tool Options

MD1F1 Output	Part No.
1/2" Square Drive (SD)	20D101600
1/2" SD with Ball Retainer	20D101602
1/2" SD X 2" Extension	20D101610
1/2" SD X 3" Extension	20D101603
1/2" SD X 4" Extension	20D101608
1/2" SD X 5" Extension	20D101604
1/2" SD X 6" Extension	20D101606
1/2" SD X 7 5/16" Extension	20D101605
1/2" SD X 8" Extension	20D101609
1/2" SD X 11" Extension	20D101607
MD1F2 Output	Part No.
1/2" Square Drive with Lock Pin	20D101601
1/2" Square Drive with Ball Pin	20D101602
MD1F1 Spring	Part No.
Standard	B4093
Heavy Duty	20R201401
MD1F2 Spring	Part No.
Standard	M4821
Heavy Duty	20R201402
Extra Heavy Duty	20D126700
Fixtured Handle	Part No.
Standard Top	20H202300
90° Top	20S105100
MD1F1 1/2" Socket Retainer	Part No.
Lock Pin	K4024
Ball Pin	K4050
Lock Pin Plug	K4025
MD1F2 1/2" Socket Retainer	Part No.
Lock Pin	20D227800
Ball Pin	20D227801
Spring	20R201413
Pin Stop	L3401

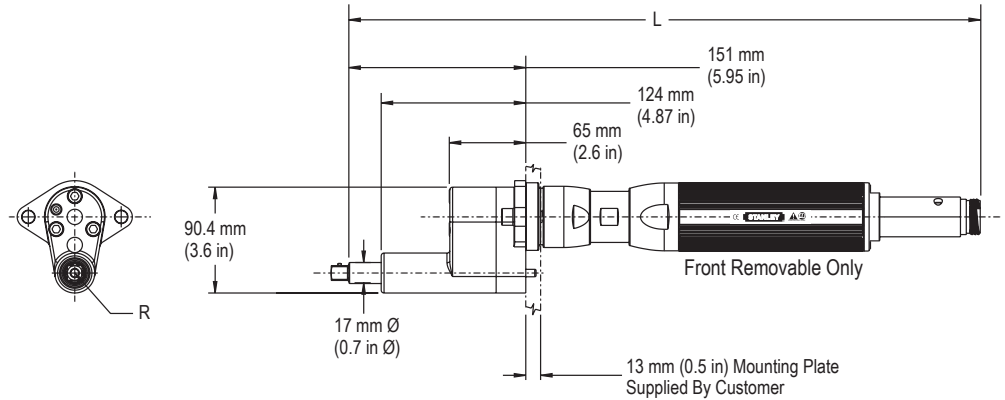

Model	Rated Speed		Torque		"R" Side to Center		"L" Length		Weight		Standard Output	
	RPM	Nm	lb ft	mm	in	mm	in	kg	lb	Retraction	SD	
E34MD1F1-54	605	54	40	17	0.67	531	20.9	4.4	9.7	25mm (1")	1/2"	
E44MD1F1-59	885	59	44	17	0.67	540	21.3	4.7	10.4			
E34MD1F1-67	490	67	49	17	0.67	531	20.9	4.4	9.7			
E44MD1F1-90	590	90	66	17	0.67	540	21.3	4.7	10.4			
E34MD1F1-90	365	90	66	17	0.67	531	20.9	4.4	9.7			
E34MD1F2-54	605	54	40	17	0.67	616	24.3	4.4	9.7	50mm (2")	1/2"	
E44MD1F2-59	885	59	44	17	0.67	628	24.7	4.7	10.4			
E34MD1F2-67	490	67	49	17	0.67	616	24.3	4.4	9.7			
E44MD1F2-90	590	90	66	17	0.67	628	24.7	4.7	10.4			
E34MD1F2-90	365	90	66	17	0.67	616	24.3	4.4	9.7			

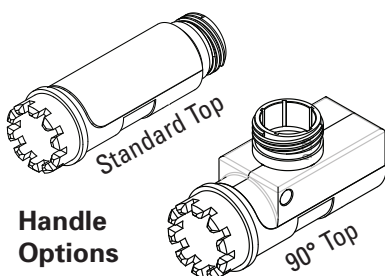

Handle Options

Offset Retractable Fixtured Tools (22.8 to 290 Nm)

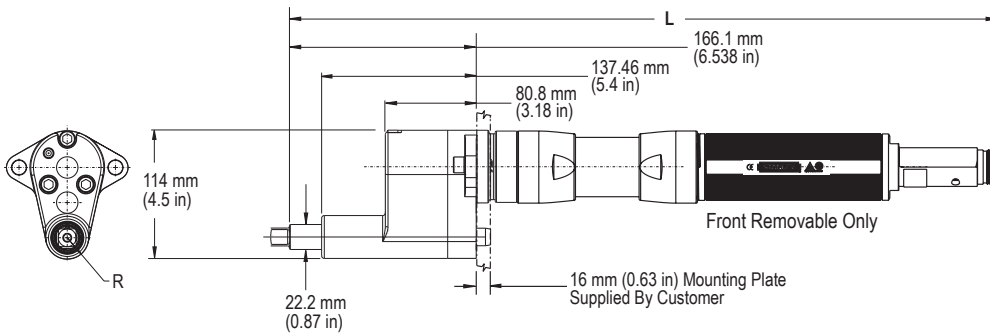

Model	Rated Speed		Torque		"R" Side to Center		"L" Length		Weight		Standard Output	
	RPM	Nm	lb ft	mm	in	mm	in	kg	lb	Retraction	SD	
E55MD2F1-114	715	114	84	19	0.75	633	24.9	8.3	18.2	25 mm (1")	5/8"	
E45MD2F1-144	345	144	106	19	0.75	605	23.8	8	17.5			
E55MD2F1-180	475	180	133	19	0.75	633	24.9	8.3	18.2			
E55MD2F1-225	380	225	166	19	0.75	630	24.8	8.3	18.2			
E55MD2F2-114	715	114	84	19	0.75	712	28	8.5	18.7	50 mm (2")	5/8"	
E45MD2F2-144	345	144	106	19	0.75	694	27.2	8.2	18			
E55MD2F2-180	475	180	133	19	0.75	712	28	8.5	18.7			

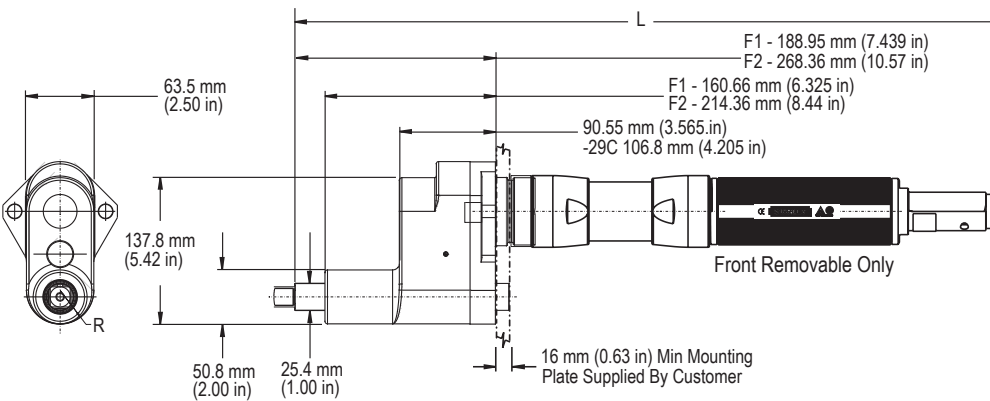

Model	Rated Speed		Torque		"R" Side to Center		"L" Length		Weight		Standard Output	
	RPM	Nm	lb ft	mm	in	mm	in	kg	lb	Retraction	SD	
E55MD3F1-114	345	114	84	32	1.25	628	24.7	10.2	22.5	25 mm (1")	3/4"	
E45MD3F1-144	345	144	106	32	1.25	628	24.7	10.2	22.5			
E55MD3F1-180	475	180	133	32	1.25	656	25.8	10.5	23.2			
E55MD3F1-225	380	225	166	32	1.25	656	25.8	10.5	23.2			
E45MD3F1-225	220	225	166	32	1.25	628	24.7	10.2	22.5			
E55MD3F1-290	380	290	214	32	1.25	710	28	11.4	25.1			
E55MD3F2-225	380	225	166	32	1.25	735	29	10.8	23.8	50 mm (2")	3/4"	
E55MD3F2-290	380	290	214	32	1.25	790	31.1	11.6	25.5			

Offset Retractable Tool Options

MD2F1 Output	Part No.
5/8" Square Drive (SD)	20D102901
5/8" SD X 2" Extension	20D102912
5/8" SD X 6" Extension	20D102913
MD2F2 Output	Part No.
5/8" Square Drive (SD)	20D102902
5/8" SD with Ball Retainer	20D102904
MD2F1 Spring	Part No.
Standard	20R201407
Heavy Duty	20D201408
MD2F2 Spring	Part No.
Light Duty	20R201423
Standard	20R201409
Heavy Duty	20R201410
Fixtured Handle	Part No.
Standard Top	20H202300
90° Top	20S105100
5/8" Socket Retainer	Part No.
Lock Pin	K4026
Ball Pin	20D227801
Lock Pin Plug	K4025
Compression Spring	20R201413
Pin Stop	L3401
MD3F1 Output	Part No.
3/4" Square Drive (SD)	20D102101
1/2" SD X 1.5" Extension	20D102106
MD3F2 Output	Part No.
3/4" Square Drive (SD)	20D102102
1/2" SD X 6" Extension	20D102105
MD3F1 Spring	Part No.
Standard	20R201403
Heavy Duty	20R201404
MD3F2 Spring	Part No.
Standard	20R201405
Heavy Duty	20R201406
3/4" Socket Retainer	Part No.
Lock Pin	A5075
Ball Pin	20R202300
Lock Pin Plug	K4025

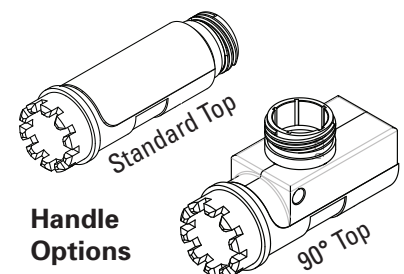



EB Tools - The QPM Flagship

This new line of STANLEY DC tools has been engineered to combine the latest technologies with STANLEY's best design features resulting in best-in-class tools.

Features and Benefits:

- Low Friction Gearing - In both gearbox and angle head assemblies for reduced noise and vibration for improved ergonomics.
- High Efficiency Motor - For best in class Power to Weight ratio.
- Full Line of Fixtured Tools - Now with optional redundant transducer and angle sensor.
- Modular Construction - For low MTTR (Mean Time To Repair).
 - » Common components reduce complexity.
 - » Handle/ Lever assembly common to all handheld tools.
 - » Entire tool line has
 - » 8 motor sizes
 - » 5 modular gear sets
 - » 6 angle heads that
 - » are field repairable
 - » have matched replacement gear sets
 - » Grease fittings on all angle tubenut and crowfoot outputs for ease of preventive maintenance.

DC Electric Tool Model Number Scheme

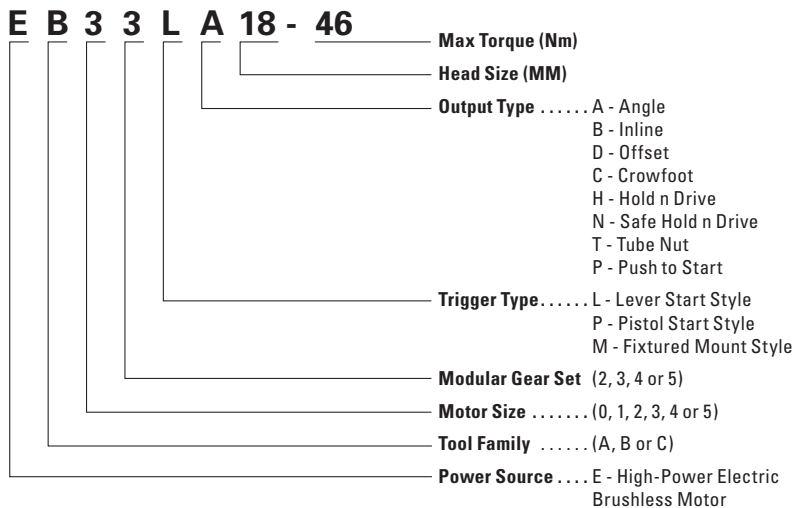

Angle tools can have gear case extensions to extend the reach of the tool. Simply add E# to the end of the tool model number to add the extended option to the tool when ordering. Where # is the length of the extension in 2 inch increments from 2 inches to 12 inches. See page 166.



Angle Lever Tools (1.2 to 60 Nm)

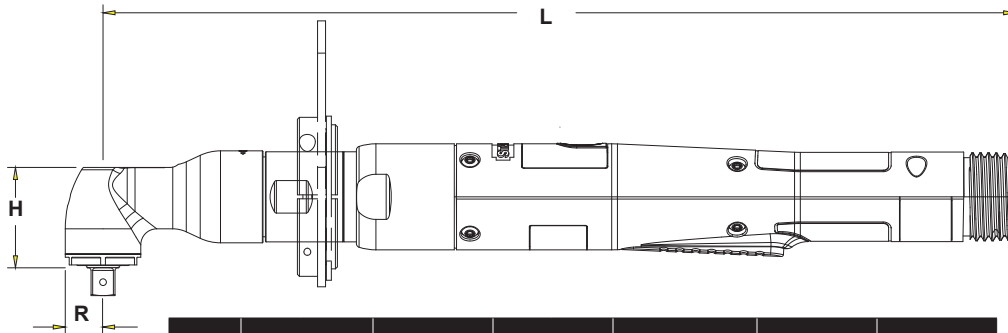

Model	Rated Speed		Torque		"R" Side to Center		"H" Head Height		"L" Length		Weight		Output
	RPM	Nm	lb ft	mm	in	mm	in	mm	in	kg	lb	Standard	
EB12LA10-6	2110	6	4.42	10	0.39	31.9	1.26	319.3	12.6	0.89	1.96	1/4" SD	
EB12LA13-8	1400	8	5.90	13	0.51	32.7	1.29	321.6	12.7	0.93	2.05	3/8" SD	
EB12LA13-13	970	13	9.58	13	0.51	32.7	1.29	321.6	12.7	0.93	2.05	3/8" SD	
EB22LA13-13	1550	13	9.58	13	0.51	32.7	1.29	343.3	13.5	1.08	2.38	3/8" SD	
EB22LA13-18	1075	18	13.3	13	0.51	32.7	1.29	343.3	13.5	1.08	2.38	3/8" SD	

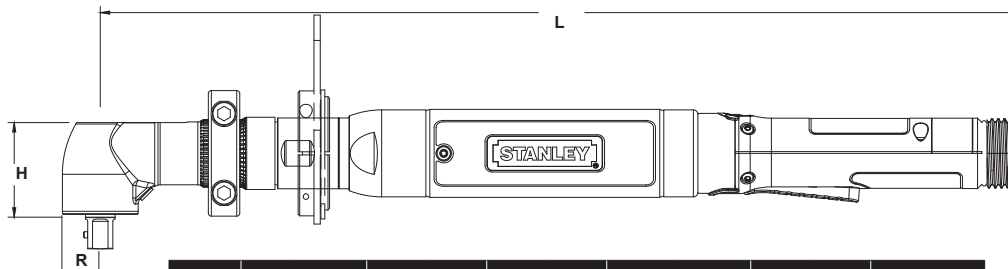

Model	Rated Speed		Torque		"R" Side to Center		"H" Head Height		"L" Length		Weight		Output
	RPM	Nm	lb ft	mm	in	mm	in	mm	in	kg	lb	Standard	
EB22LA15-24	825	24	17.7	15	0.59	36.5	1.44	366.5	14.4	1.21	2.66	3/8" SD	
EB33LA15-27	1515	27	19.91	15	0.59	36.5	1.44	415.7	16.4	1.55	3.41	3/8" SD	
EB33LA18-35	1165	35	25.81	18	0.71	39.3	1.55	444.7	17.5	1.66	3.65	3/8" SD	
EB33LA15-40	1015	40	29.49	15	0.59	36.5	1.44	415.7	16.4	1.55	3.41	3/8" SD	
EB33LA19-40	1025	40	29.49	19	0.75	48.7	1.92	458.4	18.0	1.87	4.11	1/2" SD	
EB33LA18-48	880	48	35.39	18	0.71	39.3	1.55	455.4	17.9	1.66	3.65	3/8" SD	
EB33LA19-60	680	60	44.24	19	0.75	48.7	1.92	458.4	18.0	1.87	4.11	1/2" SD	

EB Angle Tool Output Options

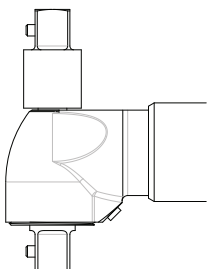

Double Ended

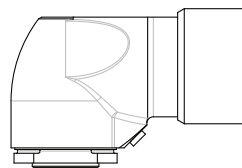

Flush

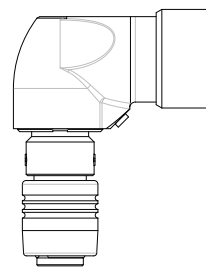

Quick Change

EB Angle Tool Options

A10 Output	Part No.
3/8" Square Drive	20D122901
1/4" Quick Change	20D122902
A13 Output	Part No.
3/8" Double-Ended, LH Thread	20D121912
Flush Socket 10mm Max*	20D121914
1/4" Quick Change	20D121916
3/8" Double-Ended, RH Thread	20D121917
Flush Socket 13mm Max*	20D121918
1/4" Square Drive	20D121919
1/4" Magnetic Internal Hex	20D121920
A15 Threaded Output 20D137500	Part No.
3/8" Square Drive	20D138900
Flush Socket *	20D138904
1/2" Square Drive	20D138901
A15 Output Splined 20D137504	Part No.
3/8" Square Drive	20D138900
Flush Socket *	20D138902
1/2" Square Drive	20D138901
A18 Output	Part No.
3/8" Square Drive	20D136500
3/8" Double-Ended, RH Thread	20D136502
Flush Socket *	20D136503
A19 Threaded Output	Part No.
Flush Socket *	20D100021
Reaction Bar (A15 Splined/ A19)	Part No.
Reaction Bar Assembly	20K100000
Mounting Flange Assembly	20K100300
Base Mount Bracket Assembly	20K100500
Suspension Bails ***	Part No.
Wire Bail (EB_2/3/4 Tools)	A3061
Swivel (A10, A13 only)	20K101402
Swivel (A18 only)	20K101400
Swivel (A19, A22 only)	20K200000
Standard (A13, A15, A18 only)	B3432
Vinyl Covers	Part No.
A10 Output	20D250711
A13 Output	20D250711
A15 Output	20D250701
A18 Output	20D250702
A19 Output	20D250707
Socket Lock Pin 3/8" or 1/2" SD	Part No.
Standard	20D227800
Rounded (Ball Detent)	20D227801

Guided Collar selection on page 175

*Flush socket selection starts on page 161

*** Suspension bails on page 174

Angle Lever Tools (11 to 400 Nm)

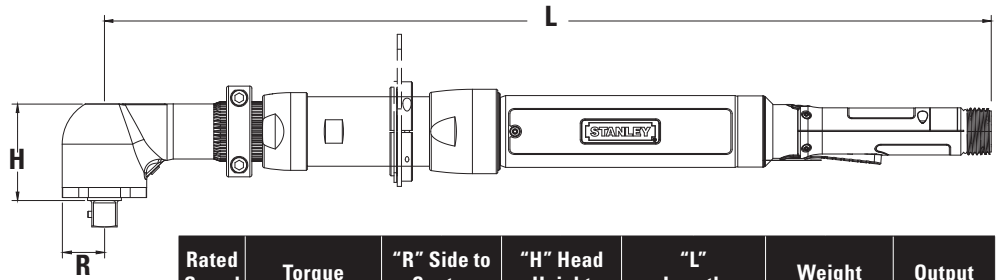

EB Angle Tool Options

A19 Splined Output	Part No.
Anti-Vibration 1/2" SD	20D100101
Flush Socket *	20D100106
1/2" Double-Ended, RH Thread	20D100107
A22A Output	Part No.
1/2" Square Drive	20D100305
Flush Socket *	20D100309
1/2" Double-Ended, RH Thread	20D100326
Reaction Bar (A19 & A22 Outputs)	Part No.
Reaction Bar Assembly	20K100000
Mounting Flange Assembly	20K100300
Base Mount Bracket Assembly	20K100500
A26 Output	Part No.
3/4" Square Drive	20D1004010
Flush Socket *	20D100409
A32 Output	Part No.
3/4" Square Drive (Pin)	20D102200
3/4" Square Drive (Ball)	20D104300
Flush Socket *	20D102201
Hex Insert #	20D102204
Reaction Bar (A26 & A32 Outputs)	Part No.
Reaction Bar, Steel (<300 Nm)	20K100200
Reaction Bar, Steel (>300 Nm)	20K100202
Base Mount Bracket	20K100600
Mounting Flange-B	20K100700
Suspension Bails ***	Part No.
Swivel (A19, A22A only)	20K200000
Swivel (A26, A32 only)	20K200100
Vinyl Covers	Part No.
A19 Output	20D250707
A22 Output	20D250708
A26 Output	20D250709
A32 Output	20D250710
Socket Lock Pin 3/8" or 1/2" SD	Part No.
Standard	20D227800
Rounded (Ball Detent)	20D227801
Socket Lock PinLock Pin 3/4" SD	Part No.
Standard	20D227800
Rounded (Ball Detent)	20D227802

Model	Rated Speed		Torque		"R" Side to Center		"H" Head Height		"L" Length		Weight		Output
	RPM	Nm	lb ft	mm	in	mm	in	mm	in	kg	lb	Standard	
EB44LA19-55	1190	55	40.55	19	0.75	48.7	1.92	458.4	18.0	2.78	6.12	1/2" SD	
EB34LA19-70	610	70	51.61	19	0.75	48.7	1.92	488.0	19.2	2.34	5.15	1/2" SD	
EB34LA22A-80	510	80	58.98	22	0.87	50.0	2.0	530.0	20.9	2.66	5.85	1/2" SD	
EB44LA22A-80	810	80	58.98	22	0.87	50.0	2.0	539	21.2	3.10	6.82	1/2" SD	
EB34LA22A-115	340	115	84.79	22	0.87	50.0	2.0	530.0	20.9	2.66	5.85	1/2" SD	
EB44LA22A-120	550	120	88.48	22	0.87	50.0	2.0	539	21.2	3.10	6.82	1/2" SD	
EB55LA26-120	825	120	88.48	26	1.02	60	2.4	632	24.9	5.19	11.42	3/4" SD	
EB55LA26-160	620	160	117.97	26	1.02	60	2.4	632	24.9	5.19	11.42	3/4" SD	
EB45LA26-165	400	165	121.65	26	1.02	60	2.4	582	22.9	4.55	10.01	3/4" SD	
EB45LA26-220	260	220	162.21	26	1.02	60	2.4	582	22.9	4.55	10.01	3/4" SD	
EB55LA26-220	460	220	162.21	26	1.02	60	2.4	632	24.9	5.19	11.42	3/4" SD	
EB55LA32-300	340	300	221.19	32	1.26	73	2.9	639	25.1	5.85	12.87	3/4" SD	
EB55LA32-400	225	400	294.92	32	1.26	73	2.9	639	25.1	5.85	12.87	3/4" SD	

#Inserts for 20D102204 A32 Hex Insert Output

Description	Part No.
1-1/8" Hex Socket Insert	A5172
30mm Hex Flush Socket Insert	20D222100
30mm with 3/4" Extension Flush Socket Insert	20D228900

The maximum hex size for the A32 Flush Socket Output is 27 mm (1-1/16"). Use the Hex Insert Output with these Inserts for larger hex sizes. This will add 16.3 mm (0.64") to the "H" dimension of the tool.

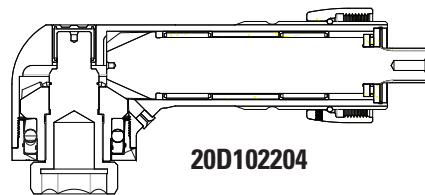

Mounting / Reaction Options

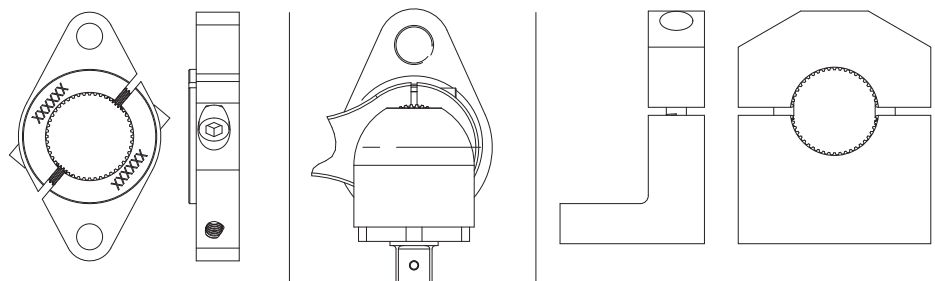

Optional Flange Mount Bracket

Reaction Bar or Bail

Optional Base Mount Bracket

Guided Collar selection on page 175
*Flush socket selection starts on page 161
*** Suspension bails on page 174

Pistol Grip Tools
(0.4 to 55 Nm)

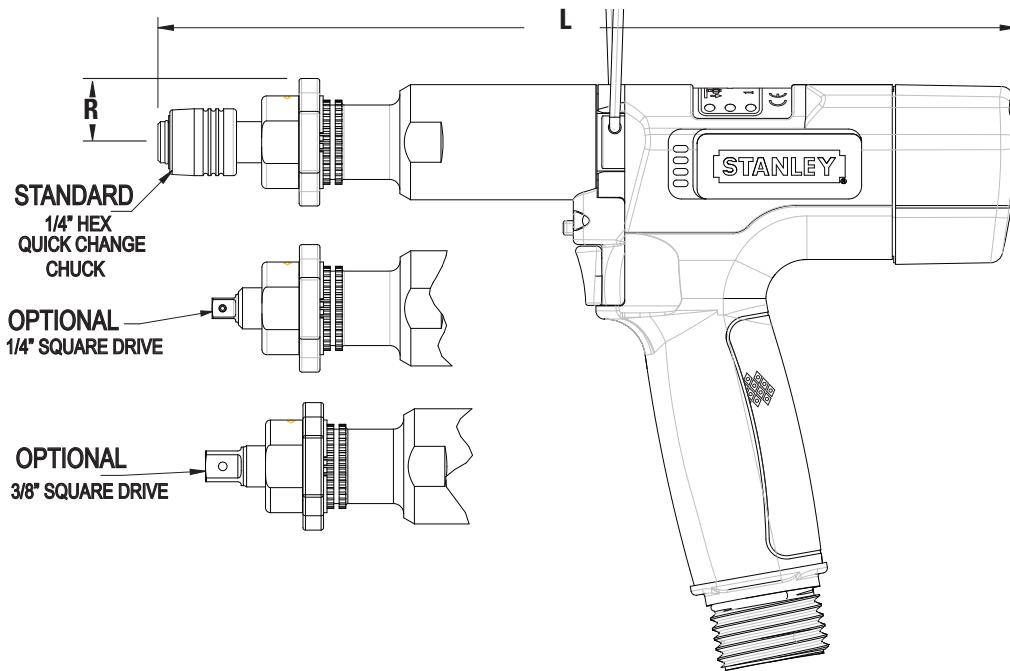

EB Pistol Tool Options

Output Options	Part No.
3/8" SD	20D119301
1/4" SD	20D119302
Socket Lock Pin 3/8" or 1/2" SD	Part No.
Standard	20D227800
Rounded (Ball Detent)	20D227801
Reaction Bar	Part No.
Spacer	20D217000
Reaction Bar 17" Long	20K100103
Reaction Bar 12" Long	20K101601
Suspension Bail	Part No.
Wire Bail	A3061

Model	Rated Speed		Torque		"R" Side to Center		"L" Length		Weight		Output
	RPM	Nm	lb ft	mm	in	mm	in	kg	lb	Standard	
EB02PB-2	1115	2	1.5	20	0.8	222	8.7	0.78	1.7	1/4 QC	
EB02PB-4	1115	4	2.9	20	0.8	222	8.7	0.78	1.7	1/4 QC	
EB12PB-4	2300	4	2.9	20	0.8	222	8.7	0.78	1.7	1/4 QC	
EB12PB-6	2300	6	4.4	20	0.8	264	10.4	0.78	1.7	1/4 QC	
EB12PB-9	1595	9	6.6	20	0.8	264	10.4	0.78	1.7	1/4 QC	
EB12PB-14	1020	14	10	20	0.8	264	10.4	0.78	1.7	1/4 QC	
EB22PB-16	1225	16	11	20	0.8	290	11.4	1.16	2.5	1/4 QC	

Model	Rated Speed		Torque		"R" Side to Center		"L" Length		Weight		Output
	RPM	Nm	lb ft	mm	in	mm	in	kg	lb	Standard	
EB33PB-28	1590	28	20	26	1.04	288	11.3	1.49	3.2	3/8" SD	
EB33PB-40	1120	40	29	26	1.04	288	11.3	1.49	3.2	3/8" SD	
EB34PB1-55	830	55	40	32	1.25	324	12.8	1.15	2.5	1/2" SD	

EB Series - Inline PTS Lever

Inline Push-to-Start (PTS) Lever Tools (0.4 to 14 Nm)

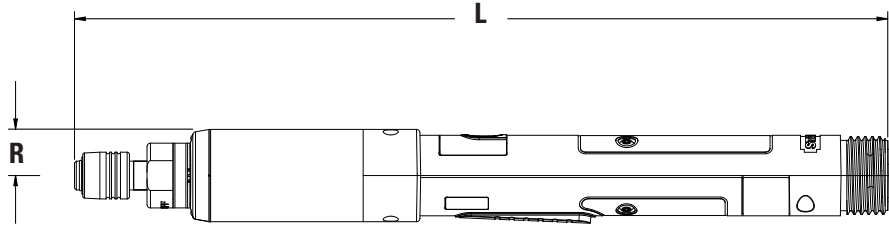

EB PTS Tool Options

EB02LP, EB12LP

Output Options	Part No.
1/4" SD	20D119302
3/8" SD Socket Lock Pin	Part No.
Standard	20D227800
Rounded (Ball Detent)	20D227801
Reaction Bar	Part No.
Reaction Bar, Aluminum 17"	20K100103
PTS Spline Cover	20D217001

Model	Rated Speed		Torque		"R" Side to Center		"L" Length		Weight		Output
	RPM		Nm	lb ft	mm	in	mm	in	kg	lb	Standard
EB02LP-2	1115		2	1.5	20.4	0.8	359	14.1	0.69	1.52	1/4" QC
EB02LP-4	1115		4	2.9	20.4	0.8	359	14.1	0.69	1.52	1/4" QC
EB12LP-6	2300		6	4.4	20.4	0.8	359	14.1	0.69	1.52	1/4" QC
EB12LP-9	1595		9	6.6	20.4	0.8	359	14.1	0.69	1.52	1/4" QC
EB12LP-14	1020		14	10.3	20.4	0.8	359	14.1	0.69	1.52	1/4" QC

Inline Lever Tools (0.4 to 14 Nm)

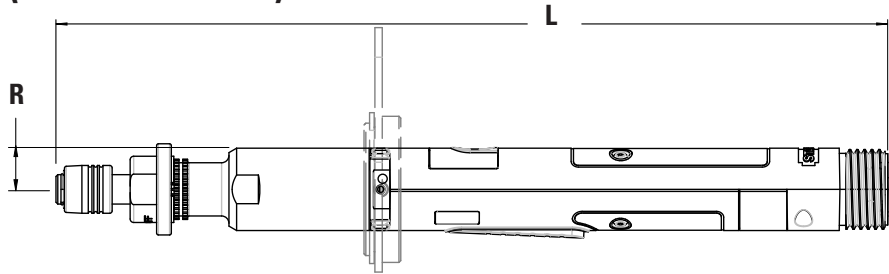

EB Inline Tool Options

EB02, EB12

Output Options	Part No.
3/8" SD	20D119301
1/4" SD	20D119302
3/8" SD Socket Lock Pin	Part No.
Standard	20D227800
Rounded (Ball Detent)	20D227801
Reaction Bar	Part No.
Reaction Bar, Aluminum	20K100103
Reaction Bar, Steel	20K100104
Suspension Bails ***	Part No.
Wire Bail	A3061
Swivel	20K101402

Model	Rated Speed		Torque		"R" Side to Center		"L" Length		Weight		Output
	RPM		Nm	lb ft	mm	in	mm	in	kg	lb	Standard
EB02LB-2	1115		2	1.5	17.8	0.7	359	14.1	0.69	1.52	1/4" QC
EB02LB-4	1115		4	2.9	17.8	0.7	359	14.1	0.69	1.52	1/4" QC
EB12LB-6	2300		6	4.4	17.8	0.7	359	14.1	0.69	1.52	1/4" QC
EB12LB-9	1595		9	6.6	17.8	0.7	359	14.1	0.69	1.52	1/4" QC
EB12LB-14	1020		14	10.3	17.8	0.7	359	14.1	0.69	1.52	1/4" QC

Inline Lever Tools
(3.2 to 2000 Nm)

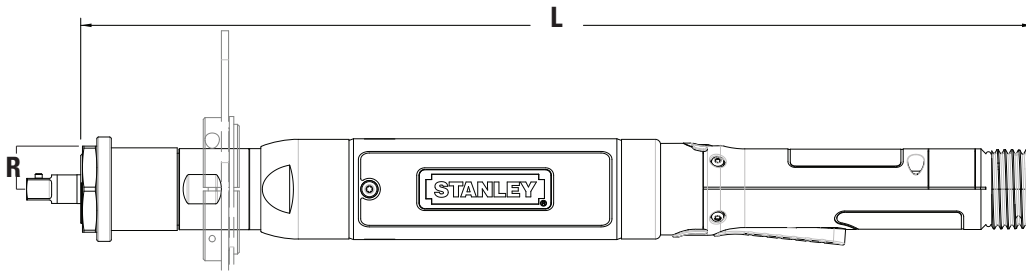

Model	Rated Speed		Torque		"R" Side to Center		"L" Length		Weight		Output
	RPM	Nm	lb ft	mm	in	mm	in	kg	lb	Standard	
EB22LB-16	1340	16	11.8	23.7	0.93	352	13.8	1.06	2.33	3/8" SD	
EB33LB-28	1590	28	20.7	24.7	0.97	416	16.4	1.40	3.08	3/8" SD	
EB33LB-40	1120	40	29.5	24.7	0.97	416	16.4	1.40	3.08	3/8" SD	

EB Inline Tool Options

EB22, EB33

Output Options	Part No.
3/8" 24-Thread	20D281100
Reaction Bar	Part No.
Reaction Bar, Aluminum	F3698
Reaction Bar, Steel	20K100100
Base Mount Bracket	A8606
Mounting Flange-B	20K101000
3/8" SD Socket Lock Pin	Part No.
Standard	20D227800
Rounded (Ball Detent)	20D227801
Suspension Bails	Part No.
Wire Bail	A3061
Swivel	20K101400
Standard	B3432

Model	Rated Speed		Torque		"R" Side to Center		"L" Length		Weight		Output
	RPM	Nm	lb ft	mm	in	mm	in	kg	lb	Standard	
EB34LB1-55	830	55	40.6	26.7	1.05	463	18.2	2.04	4.49	1/2" SD	
EB44LB1-80	895	80	59.0	26.7	1.05	479	18.9	2.48	5.46	1/2" SD	
EB44LB1-120	560	120	88.5	26.7	1.05	479	18.9	2.48	5.46	1/2" SD	
EB45LB2-140	465	140	103.3	29	1.15	533	21	3.42	7.52	3/4" SD	
EB55LB2-170	640	170	125.4	32	1.25	560	22.1	4.06	8.93	3/4" SD	
EB45LB2-190	355	190	140	29	1.15	533	21	4.3	9.46	3/4" SD	
EB55LB2-250	400	250	184.4	32	1.25	560	22.1	4.06	8.93	3/4" SD	
EB55LB3-320	310	320	236	32	1.25	573	22.5	6.49	14.28	3/4" SD	
EB55LB4-460	220	460	339.3	44	1.7	621	24.4	7.60	16.73	1" SD	
EB55LB4-620	165	620	457.2	44	1.7	621	24.4	7.60	16.73	1" SD	
EB55LB5-800	125	800	590.1	48	1.9	651	25.6	10.57	23.26	1" SD	
EB55LB5-1100	80	1100	811.4	48	1.9	651	25.6	10.57	23.25	1" SD	
EB55LB5-1500	60	1500	1106.4	48	1.9	683	26.9	10.57	23.25	1" SD	
EB55LB5-2000	50	2000	1475.2	48	1.9	683	26.9	10.57	23.25	1" SD	

EB Inline Tool Options

EB34, EB44, EB45, EB55

Reaction Bar	Part No.
Reaction Bar Assembly	20K100000
Mounting Flange Assembly	20K100300
Base Mount Bracket Assembly	20K100500
Suspension Bails	Part No.
Wire Bail	A3061
Swivel	20K200000
1/2" SD Socket Lock Pin	Part No.
Standard	20D227800
Rounded (Ball Detent)	20D227801

Mounting / Reaction Options

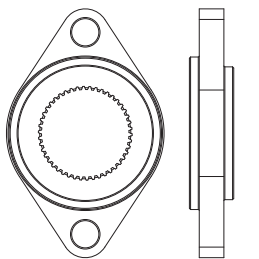

Optional Mounting Flange

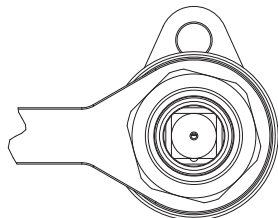

Reaction Bar / Bail

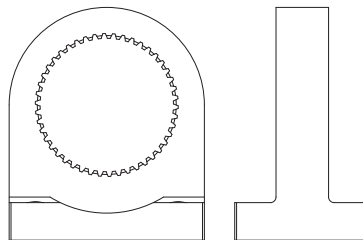

Optional Base Mount Bracket

EB Series - Crowfoot Lever

Crowfoot Lever Tools (1.6 to 216 Nm)

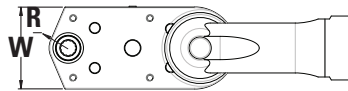

CROWFOOT OUTPUTS CAN BE WELDED AT VARIOUS ANGLES.
INDEXABLE CROWFOOT OUTPUTS ARE ALSO AVAILABLE
CONTACT STANLEY ASSEMBLY TECHNOLOGIES FOR MORE INFORMATION

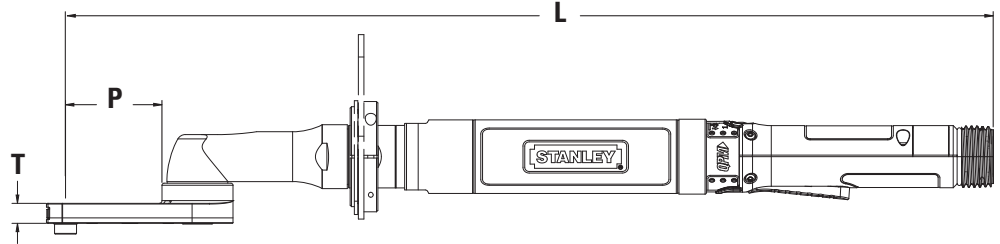

Crowfoot Tool Options

13Nm - 49Nm tools

Suspension Bails	Part No.
Optional Wire Bail	A3061
Swivel Bail	20K101400
Standard Wire Bail	B3432
See Page 176 for Crowfoot Vinyl Cover Options	
See Page 151 for Crowfoot Socket Selection	

Model	Rated Speed		Torque		"R" Nose Radius		"T" Thickness		"W" Width		"P" Length		"L" Length		Weight		Maximum Hex Size	
	RPM		Nm	lb ft	mm	in	mm	in	mm	in	mm	in	mm	in	kg	lb	mm	in
EB12LC8-8	895		8	5.9	13	0.52	16.2	0.64	25.4	1.00	44.6	1.76	382	15.0	1.06	2.33	13	1/2"
EB12LC106-8	895		8	5.9	13	0.52	16.2	0.64	25.4	1.00	64.6	2.54	401	15.8	0.68	1.50		
EB12LC8-13	680		13	9.6	13	0.52	16.2	0.64	25.4	1.00	44.6	1.76	382	15.0	1.06	2.33		
EB12LC106-13	680		13	9.6	13	0.52	16.2	0.64	25.4	1.00	64.6	2.54	401	15.8	0.68	1.50		
EB22LC8-16	895		16	11.0	13	0.52	16.2	0.64	25.4	1.00	44.6	1.76	453	17.8	1.21	2.66		
EB33LC13-22	940		22	16.2	13	0.52	20.6	0.81	31.8	1.25	47.3	1.86	530	20.8	1.17	2.57		
EB33LC69-27	990		27	19.9	13	0.52	15.9	0.63	31.8	1.25	47.3	1.86	530	20.8	1.17	2.57		
EB33LC13-30	940		30	22.1	13	0.52	20.6	0.81	31.8	1.25	47.3	1.86	530	20.8	1.17	2.57		
EB33LC246-33	880		33	24.3	16	0.63	20.6	0.81	31.8	1.25	48.3	1.90	531	20.9	1.17	2.57	14	9/16"
EB34LC298-49	595		49	36.1	13	0.52	20.9	0.82	38.1	1.50	97.1	3.82	559	22.0	1.64	3.61	13	1/2"

Model	Rated Speed		Torque		"R" Nose Radius		"T" Thickness		"W" Width		"P" Length		"L" Length		Weight		Maximum Hex Size	
	RPM		Nm	lb ft	mm	in	mm	in	mm	in	mm	in	mm	in	kg	lb	mm	in
EB34LC10-58	510		58	42.8	21	0.81	27.94	1.10	38.1	1.50	70.7	2.78	616	24.2	3.52	7.74	19	3/4"
EB44LC10-88	520		88	64.9	21	0.81	27.94	1.10	38.1	1.50	70.7	2.78	628	24.7	2.08	4.58		
EB44LC31-88	520		88	64.9	21	0.81	27.94	1.10	38.1	1.50	38.9	1.53	596	23.4	2.08	4.58		
EB44LC31-102	520		102	75.2	21	0.81	27.94	1.10	38.1	1.50	38.9	1.53	596	23.4	2.08	4.58		
EB55LC21-216	290		216	159.3	29	1.16	30.86	1.21	58.7	2.31	57.8	2.27	724	28.5	3.06	6.73	27	1-1/8"

These models are the more common of the standard 278 Crowfoot outputs STANLEY Assembly Technologies has designed over the last 50 years. Contact STANLEY Assembly Technologies for the complete list or if you would like one designed for your specific application.

Crowfoot Tool Options

58Nm - 216Nm tools

Suspension Bails	Part No.
Wire Bail	A3061
Swivel Bail	20K200000
Reaction Bar	Part No.
Reaction Bar Assembly	20K100000
Mounting Flange Assembly	20K100300
Base Mount Bracket Assembly	20K100500
See Page 176 for Crowfoot Vinyl Cover Options	
See Page 151 for Crowfoot Socket Selection	

**Tubenut Lever Tools
(4.4 to 102 Nm)**

TUBENUT OUTPUTS CAN BE WELDED AT VARIOUS ANGLES.
INDEXABLE TUBENUT OUTPUTS ARE ALSO AVAILABLE
CONTACT STANLEY ASSEMBLY TECHNOLOGIES FOR MORE INFORMATION

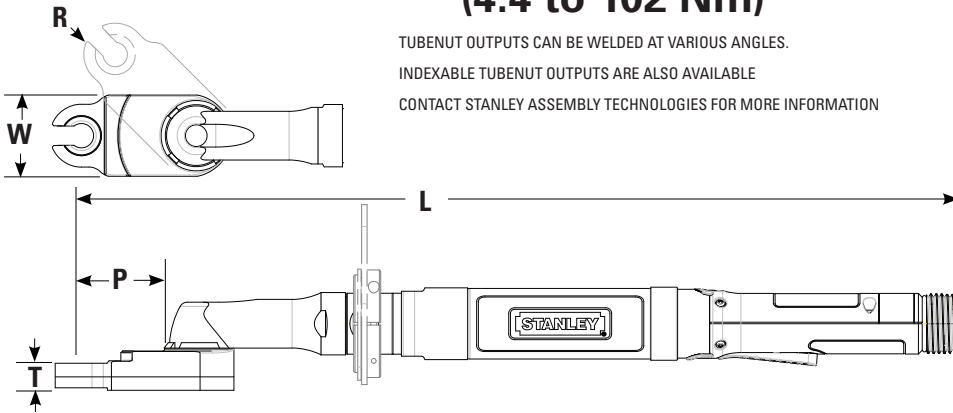

EB22/EB33 Tubenut Tool Options 25Nm - 41Nm tools

Suspension Bails	Part No.
Optional Wire Bail	A3061
Swivel Bail	20K101400
Standard Wire Bail	B3432
See Page 176 for Tubenut Vinyl Cover Options	
See Page 151 for Tubenut Socket Selection	

ANGLE	Rated Speed		Torque		"R" Nose Radius		"T" Thickness		"W" Width		"P" Length		"L" Length		Weight		Maximum Hex Size		Maximum Tube Size	
	RPM	Nm	lb ft	mm	in	mm	in	mm	in	mm	in	mm	in	kg	lb	mm	in	mm	in	
<i>Model</i>	<i>RPM</i>	<i>Nm</i>	<i>lb ft</i>	<i>mm</i>	<i>in</i>	<i>mm</i>	<i>in</i>	<i>mm</i>	<i>in</i>	<i>mm</i>	<i>in</i>	<i>mm</i>	<i>in</i>	<i>kg</i>	<i>lb</i>	<i>mm</i>	<i>in</i>	<i>mm</i>	<i>in</i>	
EB22LT358-22	635	22	16.2	11	0.43	14	0.54	42	1.7	55	2.1	454	17.9	1.79	3.93	13	0.5	8	5/16	
EB22LT252-25	500	25	18.4	13	0.52	14	0.54	42	1.7	56	2.2	434	17.1	1.79	3.93	13	0.5	8	5/16	
EB33LT346-25	1165	25	18.4	13	0.52	14	0.54	42	1.7	34	1.3	511	20.1	2.34	5.15	13	0.5	8	5/16	
EB33LT572-25	1165	25	18.4	13	0.52	14	0.54	42	1.7	34	1.3	518	20.4	2.34	5.15	13	0.5	8	5/16	
EB33LT74-30	460	30	22.1	18	0.73	14	0.54	48	1.9	44	1.7	517	20.3	2.20	4.85	18	0.7	11	7/16	
EB33LT375-41	710	41	30.2	13	0.52	22	0.85	44	1.7	59	2.3	466	8.3	2.48	5.45	13	0.5	8	5/16	

INLINE	Rated Speed		Torque		"R" Nose Radius		"T" Thickness		"W" Width		"P" Length		"L" Length		Weight		Maximum Hex Size		Maximum Tube Size	
	RPM	Nm	lb ft	mm	in	mm	in	mm	in	mm	in	mm	in	kg	lb	mm	in	mm	in	
<i>Model</i>	<i>RPM</i>	<i>Nm</i>	<i>lb ft</i>	<i>mm</i>	<i>in</i>	<i>mm</i>	<i>in</i>	<i>mm</i>	<i>in</i>	<i>mm</i>	<i>in</i>	<i>mm</i>	<i>in</i>	<i>kg</i>	<i>lb</i>	<i>mm</i>	<i>in</i>	<i>mm</i>	<i>in</i>	
EB22LT252-25	500	25	18.4	13	0.52	14	0.54	42	1.7	56	2.2	434	17.1	1.79	3.93	13	0.5	8	5/16	
EB22LT571-25	500	25	18.4	13	0.52	14	0.54	42	1.7	56	2.2	434	17.1	1.79	3.93	13	0.5	8	5/16	

VERTICAL	Rated Speed		Torque		"R" Nose Radius		"T" Thickness		"W" Width		"P" Length		"L" Length		Weight		Maximum Hex Size		Maximum Tube Size	
	RPM	Nm	lb ft	mm	in	mm	in	mm	in	mm	in	mm	in	kg	lb	mm	in	mm	in	
<i>Model</i>	<i>RPM</i>	<i>Nm</i>	<i>lb ft</i>	<i>mm</i>	<i>in</i>	<i>mm</i>	<i>in</i>	<i>mm</i>	<i>in</i>	<i>mm</i>	<i>in</i>	<i>mm</i>	<i>in</i>	<i>kg</i>	<i>lb</i>	<i>mm</i>	<i>in</i>	<i>mm</i>	<i>in</i>	
EB34LT150-30	945	30	22.1	18	0.73	14	0.56	48	1.9	47	1.9	521	20.5	2.73	5.99	19	0.75	11	7/16	

ANGLE	Rated Speed		Torque		"R" Nose Radius		"T" Thickness		"W" Width		"P" Length		"L" Length		Weight		Maximum Hex Size		Maximum Tube Size	
	RPM	Nm	lb ft	mm	in	mm	in	mm	in	mm	in	mm	in	kg	lb	mm	in	mm	in	
<i>Model</i>	<i>RPM</i>	<i>Nm</i>	<i>lb ft</i>	<i>mm</i>	<i>in</i>	<i>mm</i>	<i>in</i>	<i>mm</i>	<i>in</i>	<i>mm</i>	<i>in</i>	<i>mm</i>	<i>in</i>	<i>kg</i>	<i>lb</i>	<i>mm</i>	<i>in</i>	<i>mm</i>	<i>in</i>	
EB34LT150-30	945	30	22.1	18	0.73	14	0.56	48	1.9	47	1.9	521	20.5	2.73	5.99	19	0.75	11	7/16	
EB34LT23-41	695	41	30.2	18	0.73	23	0.91	48	1.9	44	1.7	575	22.6	3.07	6.75	18	0.71	11	7/16	
EB34LT99-62	460	62	45.7	26	1.04	20	0.76	75	2.9	65	2.5	604	23.8	2.93	6.45	27	1.06	19	3/4	
EB44LT20-102	430	102	75.2	26	1.04	32	1.24	75	2.9	65	2.5	628	24.7	4.46	9.82	27	1.06	19	3/4	

These models are the more common of the standard 104 Tubenut outputs STANLEY Assembly Technologies has designed over the last 50 years. Contact STANLEY Assembly Technologies for the complete list or if you would like one designed for your specific application.

Mounting / Reaction Options

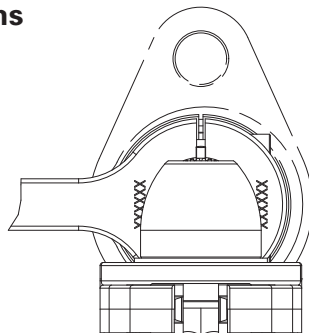

EB_4 Tubenut Tool Options 30Nm - 102Nm tools

Suspension Bails	Part No.
Wire Bail	A3061
Swivel Bail	20K200000
See Page 176 for Tubenut Vinyl Cover Options	
See Page 151 for Tubenut Socket Selection	

EB Series - Hold and Drive Lever - 1"

1" H&D Lever Tool Options

H18 Output	Part No.
Socket Options*	20D905700
1" Travel Bit Holder Output	20D124600
1" Travel Tang Holder Output	20D124602
H18 Tang Holder	Part No.
6mm x 8mm Rectangle	20D261700
5mm x 7.5mm Rectangle	20D261701
6mm x 10mm Rectangle	20D261702
6mm Hex *	20D261703
H18 Bit Holder	Part No.
1/4" Hex*	20D254200
5/16" Hex*	20D253400
H22 Output	Part No.
Socket Options*	~N4617
1" Travel Tang Holder Output	20D103211
1" Travel Bit Holder Output	20D103212
H22 Tang Holder	Part No.
Female Tang Holder Options	~F4287
H22 Bit Holder	Part No.
Bit Holder Options *	~F4288
H22 Reaction Bar	Part No.
Reaction Bar Assembly	20K100000
Mounting Flange Assembly	20K100300
Base Mount Bracket Assembly	20K100500
H26 Output	Part No.
Socket Options *	~F4285
1" Travel Tang Holder Output	20D103601
1" Travel Bit Holder Output	20D103602
H26 Tang Holder	Part No.
Female Tang Holder Options *	~H4948
H26 Bit Holder	Part No.
Bit Holder Options *	~H4947
H26 Reaction Bar	Part No.
Reaction Bar Assembly	20K100200
Mounting Flange Assembly	20K100700
Base Mount Bracket Assembly	20K100600
Reaction Bar Assembly, HD	20K100202
H32 Output	Part No.
Socket Options *	~A5302
1" Travel Tang Holder Output	20D103701
1" Travel Bit Holder Output	20D103702

* Socket, Bit and Tang selections start on page 165

Hold & Drive Tools (9.2 to 380 Nm) - 1" Output

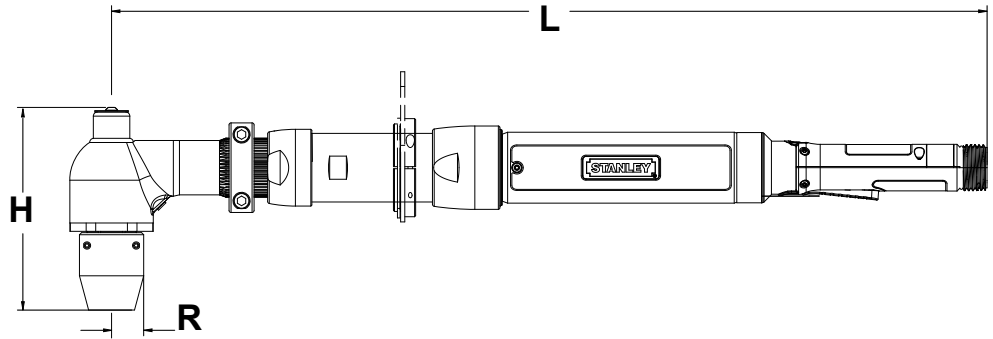

Model	Rated Speed		Torque		"R" Side to Center		"H" Head Height		"L" Length		Weight		Travel
	RPM	Nm	lb ft	mm	in	mm	in	mm	in	kg	lb	Standard	
EB33LH18V1-46	880	46	33.9	18	0.71	131.9	5.2	464	18.3	2.2	4.9	1"	
EB34LH22AV1-77	510	77	56.8	22	0.87	143.8	5.7	521	20.5	3.1	6.8		
EB34LH22AV1-110	335	110	81.1	22	0.87	143.8	5.7	543	21.4	3.1	6.8		
EB45LH26V1-155	400	155	114.3	26	1.02	142.8	5.6	582	22.9	4.6	10.0		
EB45LH26V1-220	260	220	162.3	26	1.02	142.8	5.6	582	22.9	4.6	10.0		
EB55LH32V1-285	340	285	210.2	32	1.3	179.6	7.1	639	25.1	6.2	13.6		
EB55LH32V1-380	225	380	280.3	32	1.3	179.6	7.1	639	25.1	6.2	13.6		

1" DC H&D Lever Tool Options

H32 Tang Holder	Part No.
Female Tang Holder Options*	20D900601
H32 Bit Holder	Part No.
Bit Holder Options *	20D900602
H32 Reaction Bar	Part No.
Reaction Bar Assembly	20K100200
Mounting Flange Assembly	20K100700
Base Mount Bracket Assembly	20K100600
Reaction Bar Assembly, HD	20K100202

Hold & Drive Options

A Tang holds the bolt while the nut is tightened

Typical Tang Options



Female Torx



Female Hex



Rectangular

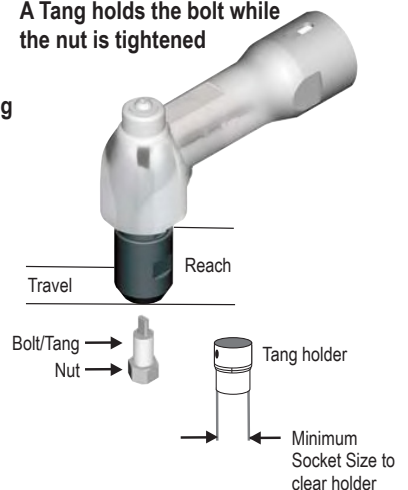

NOTE: The bolt can extend beyond the nut no more than the specified Travel distance when tightened.

Hold & Drive Tools (9.2 to 380 Nm) - 2" Output

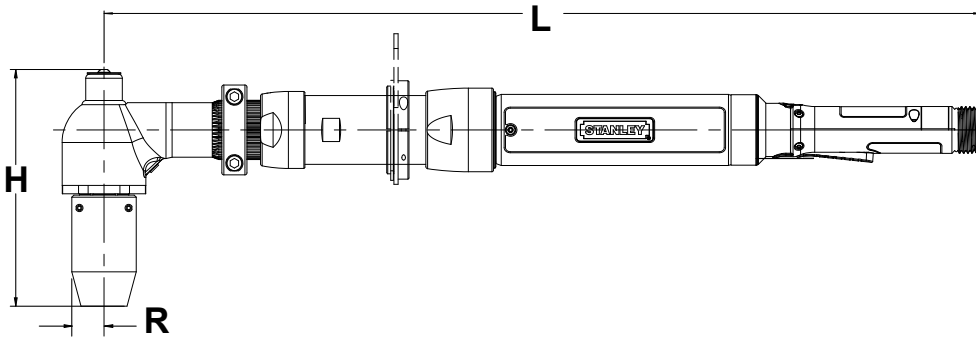

Model	Rated Speed	Torque		"R" Side to Center		"H" Head Height		"L" Length		Weight		Travel
	RPM	Nm	lb ft	mm	in	mm	in	mm	in	kg	lb	Standard
EB33LH18V2-46	880	46	33.9	18	0.71	190.3	7.5	464	18.3	2.2	4.9	2"
EB34LH22AV2-77	510	77	56.8	22	0.87	199.0	7.8	521	20.5	3.1	6.8	
EB34LH22AV2-110	335	110	81.1	22	0.87	199.0	7.8	543	21.4	3.1	6.8	
EB45LH26V2-155	400	155	114.3	26	1.02	168.2	6.6	582	22.9	4.6	10.0	
EB45LH26V2-220	260	220	162.3	26	1.02	168.2	6.6	582	22.9	4.6	10.0	
EB55LH32V2-285	340	285	210.2	32	1.3	205	8.1	639	25.1	6.2	13.6	
EB55LH32V2-380	225	380	280.3	32	1.3	205	8.1	639	25.1	6.2	13.6	

2" H&D Lever Tool Options

H18 Output	Part No.
Socket Options *	20D905700
2" Travel Bit Holder Output	20D124601
2" Travel Tang Holder Output	20D124603
H18 Tang Holder	Part No.
6mm x 8mm Rectangle	20D261700
5mm x 7.5mm Rectangle	20D261701
6mm x 10mm Rectangle	20D261702
6mm Hex	20D261703
H18 Bit Holder	Part No.
1/4" Hex *	20D254200
5/16" Hex *	20D253400
H22 Output	Part No.
Socket Options *	~N4617
2" Travel Tang Holder Output	20D103213
2" Travel Bit Holder Output	20D103214
H22 Tang Holder	Part No.
Female Tang Holder Options	~F4287
H22 Bit Holder	Part No.
Bit Holder Options *	~F4288
H22 Reaction Bar	Part No.
Reaction Bar Assembly	20K100000
Mounting Flange Assembly	20K100300
Base Mount Bracket Assembly	20K100500
H26 Output	Part No.
Socket Options *	~F4285
2" Travel Tang Holder Output	20D103603
2" Travel Bit Holder Output	20D103604
H26 Tang Holder	Part No.
Female Tang Holder Options*	~H4948
H26 Bit Holder	Part No.
Bit Holder Options *	~H4947
H26 Reaction Bar	Part No.
Reaction Bar Assembly	20K100200
Mounting Flange Assembly	20K100700
Base Mount Bracket Assembly	20K100600
Reaction Bar Assembly, HD	20K100202
H32 Output	Part No.
Socket Options *	~A5302
2" Travel Tang Holder Output	20D103703
2" Travel Bit Holder Output	20D103704

2" DC H&D Lever Tool Options

H32 Tang Holder	Part No.
Female Tang Holder Options*	20D900601
H32 Bit Holder	Part No.
Bit Holder Options *	20D900602
H32 Reaction Bar	Part No.
Reaction Bar Assembly	20K100200
Mounting Flange Assembly	20K100700
Base Mount Bracket Assembly	20K100600
Reaction Bar Assembly, HD	20K100202

A Bit holds the bolt while the nut is tightened

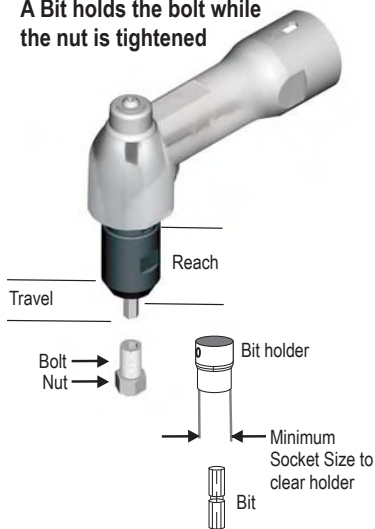

Typical Bit Options



Male Hex



Male Torx

* Socket, Bit and Tang selections start on page 165

EB Fixtured Tools



The EB Fixtured tool handle has also been redesigned and includes Red/ Green/ Yellow fastening cycle status lights for operator feedback. The cable connection can be adjusted in four 90° increments. With straight or 90° cables and this new adjustable EB fixtured tool handle, optimal cable placement in the system is a snap.

All fixtured EB tools can be supplied with a redundant set of strain gauges on the transducer with its own separate circuit. This can be used to verify operation of the standard transducer strain gauge and provide indication if the two readings fall outside specified parameters. Simply add a "R" to the end of any fixtured tool model number to have it delivered with the second strain gauge. This will also add a separate (redundant) angle circuit to compare against the first angle value.

As an example, if you wanted an EB45MB2-140 with a second torque or angle circuit, the new model number would be EB45MB2-140R.

Angle Fixtured Tools (8 to 60 Nm)

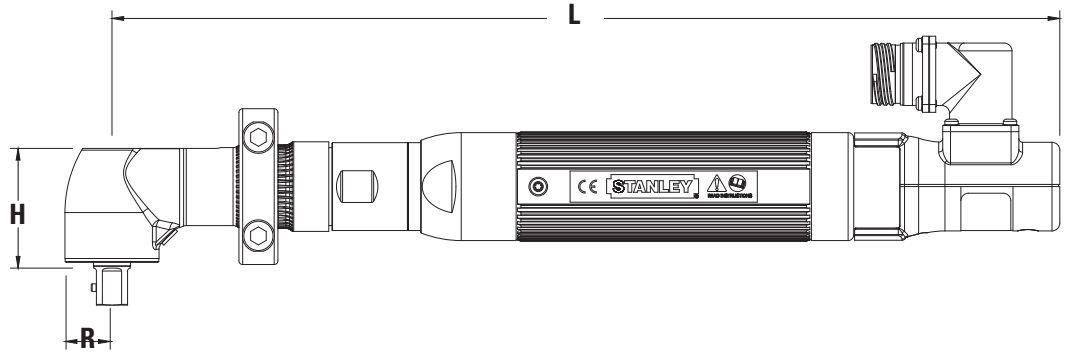

EB Angle Fixtured Options

EB33

A19 Threaded Output	Part No.
Flush Socket *	20D100021
Suspension Bails	Part No.
Wire Bail	A3061
Swivel	20K200000
Standard	B3432
Reaction Device	Part No.
Reaction Bar, Steel	20K100100
Base Mount Bracket	20K100500
Mounting Flange-B	20K100300

*Flush socket selection starts on page 161

Angle Head Covers on page 176

Model	Rated Speed	Torque		"R" Side to Center		"H" Head Height		"L" Length		Weight		Output
	RPM	Nm	lb ft	mm	in	mm	in	mm	in	kg	lb	Standard
EB33MA19-40	1025	40	29.5	19	0.75	48.7	1.92	385	15.1	1.9	4.11	1/2" SD
EB33MA19-60	680	60	44.2	19	0.75	48.7	1.92	385	15.1	1.9	4.11	

Mounting / Reaction Options

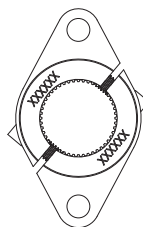

Optional Flange Mount Bracket

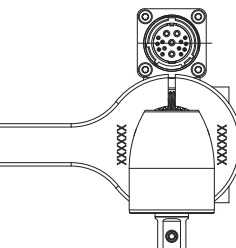

Standard Reaction Bar

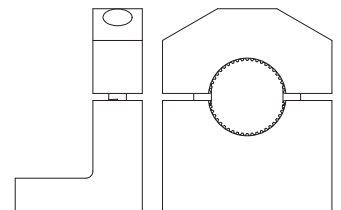

Optional Base Mount Bracket

Angle Fixtured Tools (24 to 400 Nm)

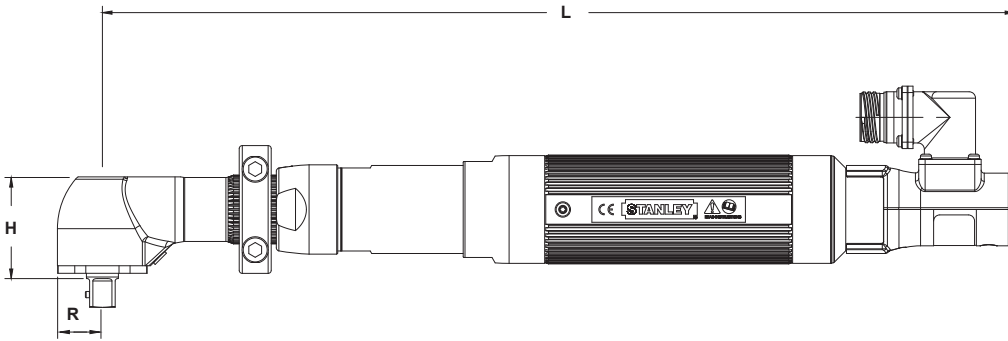

Model	Rated Speed		Torque		"R" Side to Center		"H" Head Height		"L" Length		Weight		Output
	RPM	Nm	lb ft	mm	in	mm	in	mm	in	kg	lb	Standard	
EB44MA19-55	1190	55	40.6	19	0.75	48.7	1.92	445	7.5	2.8	6.16	1/2" SD	
EB34MA19-70	610	70	51.6	19	0.75	48.7	1.92	433	17.0	2.3	5.15		
EB34MA22A-80	510	80	59.0	22	0.87	50.0	2.00	441	17.4	2.7	5.94		
EB44MA22A-80	810	80	59.0	22	0.87	50.0	2.00	453	17.8	3.1	6.82		
EB34MA22A-115	340	115	84.8	22	0.87	50.0	2.00	463	18.2	2.7	5.94		
EB44MA22A-120	550	120	88.5	22	0.87	50.0	2.00	453	17.8	3.1	6.82		

EB Angle Fixtured Options

EB34, EB44

A19 Splined Output	Part No.
Anti-Vibration 1/2" SD	20D100101
Flush Socket*	20D100106
1/2" Double-Ended, RH Thread	20D100107
A22A Output	Part No.
Flush Socket*	20D100309
1/2" Double-Ended, RH Thread	20D100326
Reaction Device	Part No.
Reaction Bar, Steel	20K100000
Base Mount Bracket	20K100500
Mounting Flange	20K100302
1/2" SD Socket Lock Pin	Part No.
Standard	20D227800
Rounded (Ball Detent)	20D227801

*Flush socket selection starts on page 153

Angle Head Covers on page 168

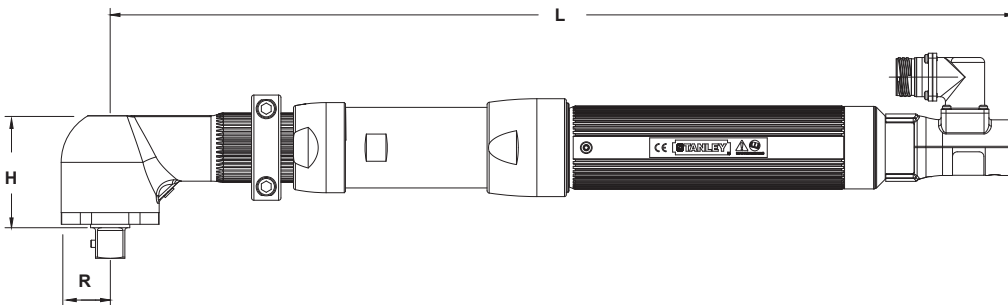

Model	Rated Speed		Torque		"R" Side to Center		"H" Head Height		"L" Length		Weight		Output
	RPM	Nm	lb ft	mm	in	mm	in	mm	in	kg	lb	Standard	
EB55MA26-120	825	120	88.5	26	1.02	60	2.4	557	21.9	5.2	11.4	3/4" SD	
EB55MA26-160	620	160	118	26	1.02	60	2.4	557	21.9	5.2	11.4		
EB45MA26-165	400	165	122	26	1.02	60	2.4	503	19.8	4.6	10.0		
EB45MA26-220	260	220	162	26	1.02	60	2.4	527	20.7	4.6	10.0		
EB55MA26-220	460	220	162	26	1.02	60	2.4	556	21.9	5.2	11.4		
EB55MA32-300	340	300	221	32	1.3	73	2.9	563	22.1	5.9	12.9		
EB55MA32-400	225	400	295	32	1.3	73	2.9	563	22.1	5.9	12.9		

EB Angle Fixtured Options

EB45, EB55

A26 Output	Part No.
Flush Socket*	20D100409
5/8" Square Drive	20D100400
Reaction Device	Part No.
Reaction Bar, Steel	20K100200
Reaction Bar, Steel, Heavy Duty	20K100202
Base Mount Bracket	20K100600
Mounting Flange-B	20K100700
3/4" SD Socket Lock Pin	Part No.
Standard	20D227800
Rounded (Ball Detent)	20D227802

*Flush socket selection starts on page 161

Angle Head Covers on page 176

EB Series - Angle Retractable Fixtured Tools

Angle Retractable Fixtured Tools (8 to 120 Nm)

EB Angle Retractable Fixtured Options

EB33

Spring Options	Part No.
Standard	A5313
8 lb Compression	20R201407
Output Options	Part No.
2" Extended Output	20D115901
Reaction Device	Part No.
Reaction Bar, Steel	20K100000
Base Mount Bracket	20K100500
Mounting Flange-B	20K100300
Suspension Bails	Part No.
Wire Bail	A3061
Swivel	20K200000
Standard	B3432
1/2" SD Socket Lock Pin	Part No.
Standard	20D227800
Rounded (Ball Detent)	20D227801

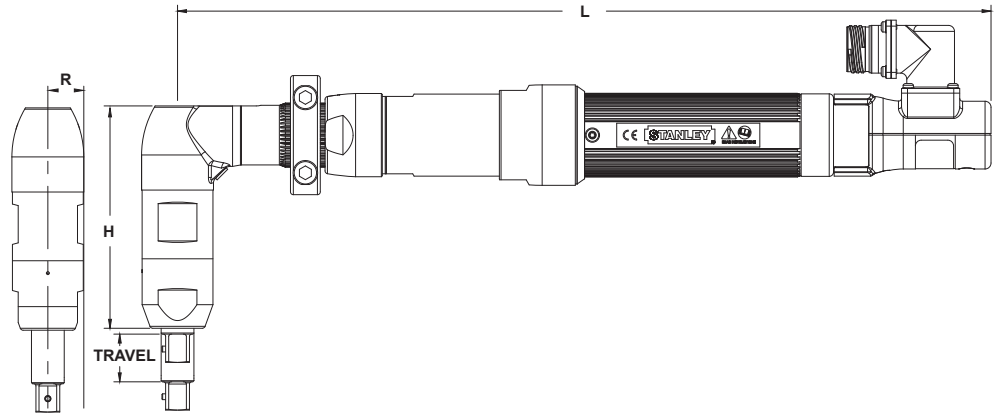

Model	Rated Speed		Torque		"R" Side to Center		"H" Head Height		"L" Length		Weight		Output	
	RPM	Nm	lb ft	mm	in	mm	in	mm	in	kg	lb	Retraction	Standard	
EB33MA19F1-40	1025	40	29.5	19	0.75	146.5	5.8	385	15.1	1.87	4.11	25mm 1"	1/2" SD	
EB33MA19F1-60	680	60	44.2	19	0.75	146.5	5.8	385	15.1	1.87	4.11			
EB44MA19F1-55	1190	55	40.6	19	0.75	146.5	5.8	445	17.5	3.18	7.02			
EB34MA19F1-70	610	70	51.6	19	0.75	146.5	5.8	433	17.0	2.74	6.05			

Angle Head Covers on page 168

EB Angle Retractable Fixtured Options

EB34, EB44

Spring Options	Part No.
Standard	M4283
5.8 lb Compression	H4003
8.6 lb Compression	M4800
Output Options	Part No.
2" Extended Output	M4306
2-5/8" Extended Output	20D117700
8" Extended Output	M4466
Reaction Device	Part No.
Reaction Bar, Steel	20K100100
Base Mount Bracket	20K100500
Mounting Flange	20K100302
1/2" SD Socket Lock Pin	Part No.
Standard	20D227800
Rounded (Ball Detent)	20D227801

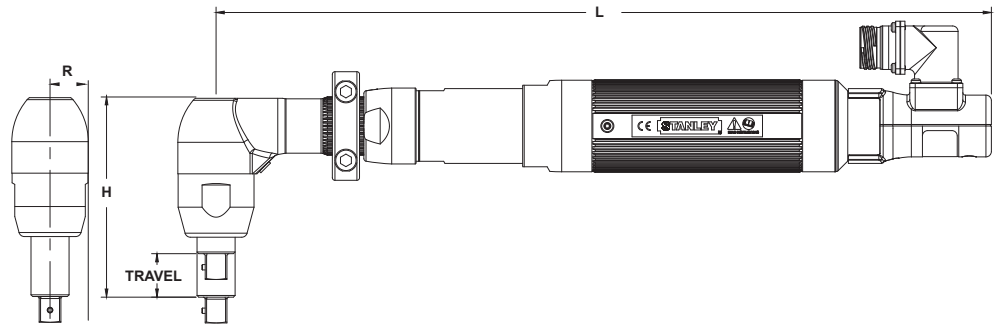

Model	Rated Speed		Torque		"R" Side to Center		"H" Head Height		"L" Length		Weight		Output	
	RPM	Nm	lb ft	mm	in	mm	in	mm	in	kg	lb	Retraction	Standard	
EB34MA22AF1-80	510	80	59.0	22	0.87	114	4.5	441	17.4	3.1	6.75	25mm 1"	1/2" SD	
EB44MA22AF1-80	810	80	59.0	22	0.87	114	4.5	453	17.8	3.5	7.72			
EB34MA22AF1-115	340	115	84.8	22	0.87	114	4.5	463	18.2	3.1	6.75			
EB44MA22AF1-120	550	120	88.5	22	0.87	114	4.5	453	17.8	3.5	7.72			

Angle Head Covers on page 176

Angle Retractable Fixtured Tools (24 to 400 Nm)

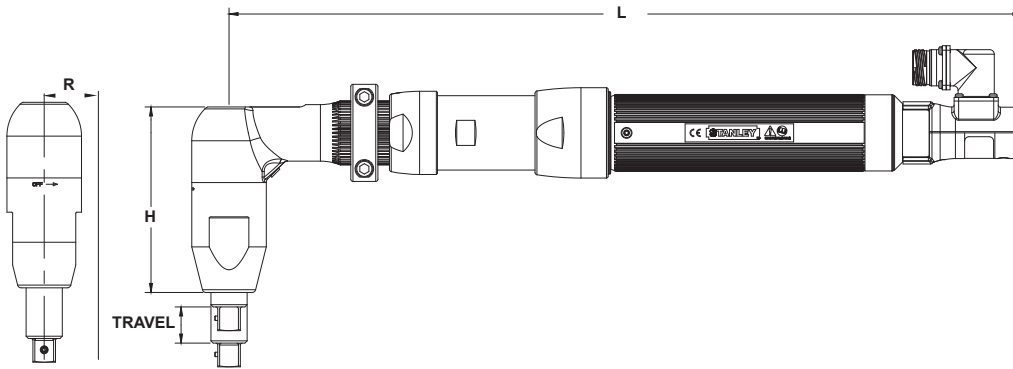

Model	Rated Speed		Torque			"R" Side to Center		"H" Head Height		"L" Length		Weight		Output	
	RPM	Nm	lb ft	mm	in	mm	in	mm	in	kg	lb	Retraction	Standard		
EB55MA26F1-120	825	120	88.5	26	1.02	166	6.5	557	21.9	5.2	11.4	25mm 1"	3/4" SD		
EB55MA26F1-160	620	160	118	26	1.02	166	6.5	557	21.9	5.2	11.4				
EB45MA26F1-165	400	165	122	26	1.02	166	6.5	503	19.8	4.6	10.0				
EB45MA26F1-220	260	220	162	26	1.02	166	6.5	527	20.7	4.6	10.0				
EB55MA26F1-220	460	220	162	26	1.02	166	6.5	557	21.9	5.2	11.4				

EB Angle Retractable Fixtured Options

EB45, EB55

Spring Options	Part No.
Standard	20R201414
11 lb Compression	20R201417
Reaction Device	Part No.
Reaction Bar, Steel	20K100200
Reaction Bar, Steel	20K100202
Base Mount Bracket	20K100600
Mounting Flange-B	20K100700
3/4" SD Socket Lock Pin	Part No.
Standard	20D227800
Rounded (Ball Detent)	20D227802

Angle Head Covers on page 168

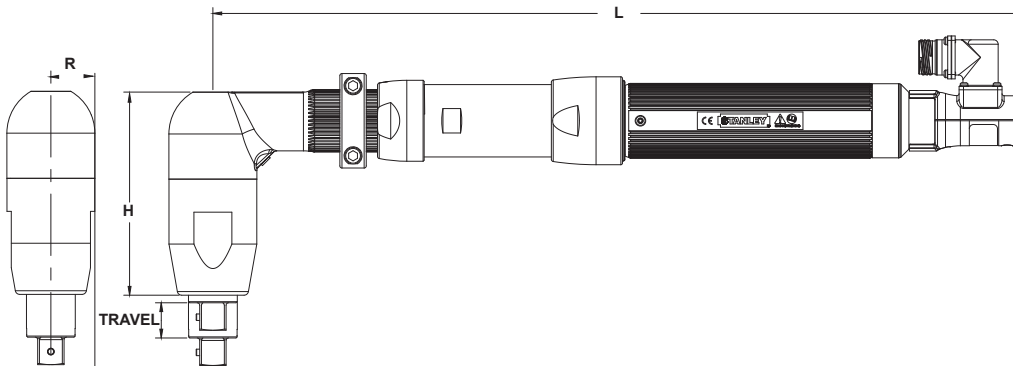

Model	Rated Speed		Torque			"R" Side to Center		"H" Head Height		"L" Length		Weight		Output	
	RPM	Nm	lb ft	mm	in	mm	in	mm	in	kg	lb	Retraction	Standard		
EB55MA32F1-300	340	300	221	32	1.26	178	7.0	563	22.1	5.9	12.9	25mm 1"	3/4" SD		
EB55MA32F1-400	225	400	295	32	1.26	178	7.0	563	22.1	5.9	12.9				

EB Angle Retractable Fixtured Options

EB55 Models

Spring Options	Part No.
Standard	M4606
7.6 lb Compression	M4331
Output Options	Part No.
2.5" Extended Output	20D114800
4" Extended Output	M4740
Reaction Device	Part No.
Reaction Bar, Steel	20K100200
Reaction Bar, Steel	20K100202
Base Mount Bracket	20K100600
Mounting Flange-B	20K100700
3/4" SD Socket Lock Pin	Part No.
Standard	20D227800
Rounded (Ball Detent)	20D227802

Angle Head Covers on page 176

Mounting / Reaction Options

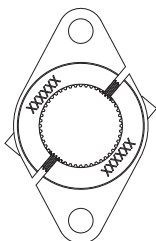

Optional Flange Mount Bracket

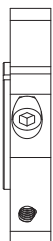

Standard Reaction Bar

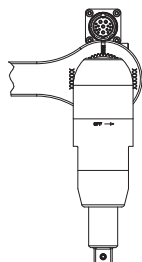

Optional Base Mount Bracket

EB Series - Inline Fixtured Tools

Inline Fixtured Tools (5.6 to 120 Nm)

EB Inline Fixtured Options

EB33

Reaction Device	Part No.
Reaction Bar, Aluminum	F3698
Reaction Bar, Steel	20K100100
Base Mount Bracket	A8606
Mounting Flange-B	20K101000
Suspension Bails	Part No.
Wire Bail	A3061
Swivel	20K101400
Standard	B3432
3/8" SD Socket Lock Pin (EB33)	Part No.
Standard	20D227800
Rounded (Ball Detent)	20D227801

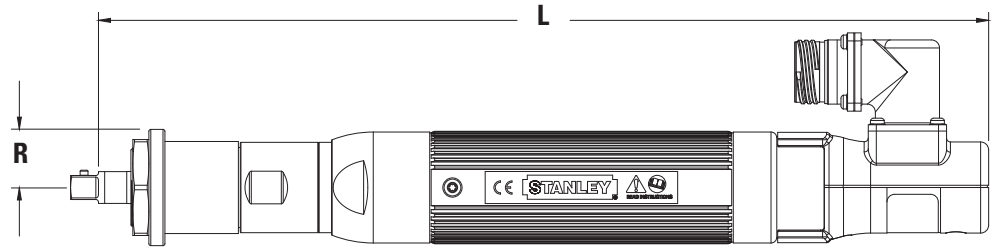

Model	Rated Speed		Torque		"R" Side to Center		"L" Length		Weight		Output
	RPM	Nm	lb ft	mm	in	mm	in	kg	lb	Standard	
EB33MB-28	1590	28	20.6	24	0.93	359	14.1	1.6	3.52	3/8" SD	
EB33MB-40	1120	40	29.5	24	0.93	385	15.1	1.6	3.52		

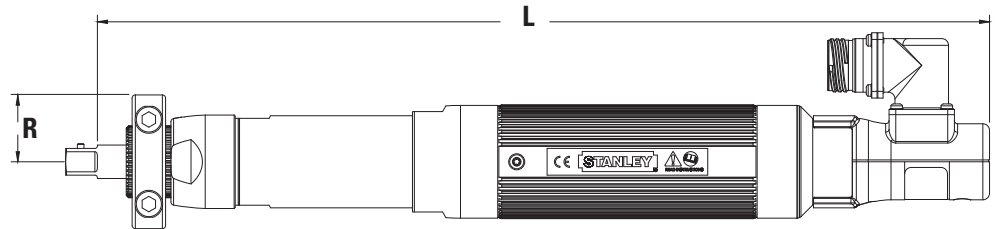

EB Inline Fixtured Options

EB34, EB44

Reaction Device	Part No.
Reaction Bar, Steel	20K100100
Base Mount Bracket	20K100500
Mounting Flange-B	20K100300
1/2" SD Socket Lock Pin	Part No.
Standard	20D227800
Rounded (Ball Detent)	20D227801

Model	Rated Speed		Torque		"R" Side to Center		"L" Length		Weight		Output
	RPM	Nm	lb ft	mm	in	mm	in	kg	lb	Standard	
EB34MB1-55	830	55	40.5	32	1.03	421	16.6	2.2	4.84	1/2" SD	
EB44MB1-80	895	80	59	32	1.03	421	16.6	2.7	5.94		
EB44MB1-120	557	120	88.5	32	1.03	421	16.6	2.7	5.94		

Mounting / Reaction Options

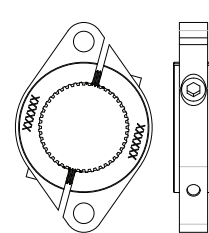

Optional Flange Mount Bracket

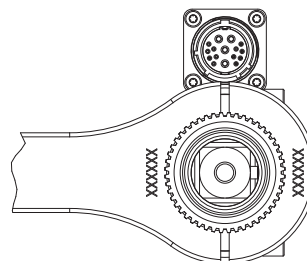

Standard Reaction Bar

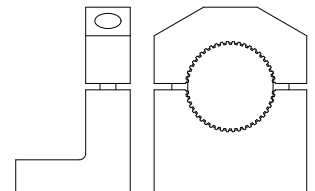

Optional Base Mount Bracket

Inline Fixtured Tools (28 to 2000 Nm)

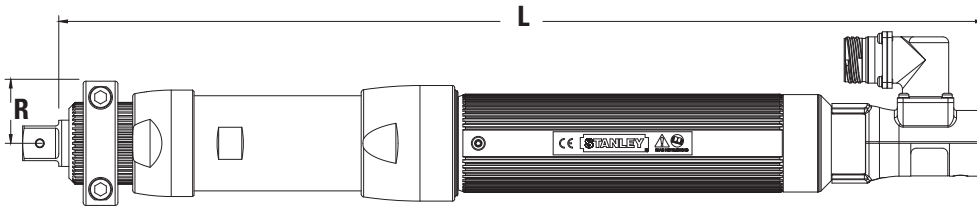

Model	Rated Speed		Torque		"R" Side to Center		"L" Length		Weight		Output
	RPM	Nm	lb ft	mm	in	mm	in	kg	lb	Standard	
EB45MB2-140	465	140	103	34	1.34	475	18.7	3.6	7.92	3/4" SD	
EB55MB2-170	640	170	125	34	1.34	475	18.7	4.3	9.46	3/4" SD	
EB45MB2-190	355	190	140	34	1.34	475	18.7	4.3	9.46	3/4" SD	
EB55MB2-250	400	250	184	34	1.34	475	18.7	4.3	9.46	3/4" SD	

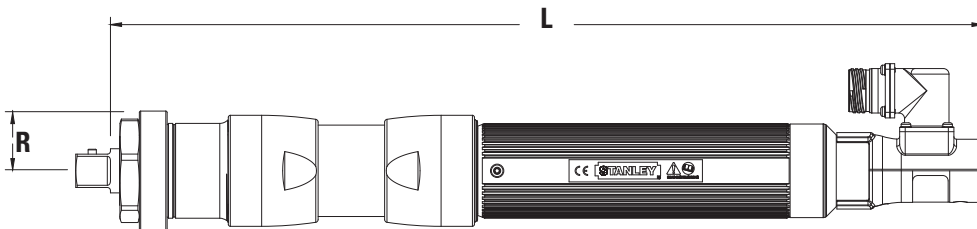

Model	Rated Speed		Torque		"R" Side to Center		"L" Length		Weight		Output
	RPM	Nm	lb ft	mm	in	mm	in	kg	lb	Standard	
EB55MB3-320	310	320	236	35	1.38	517	20.4	6.7	14.74	3/4" SD	

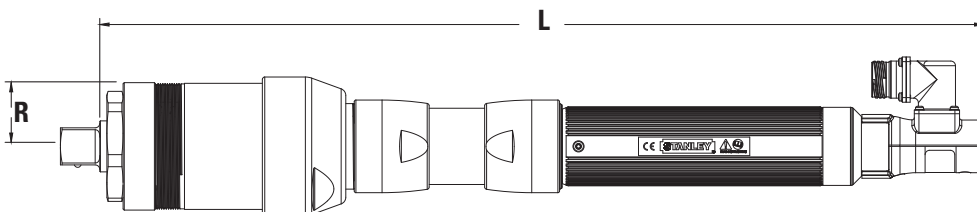

Model	Rated Speed		Torque		"R" Side to Center		"L" Length		Weight		Output
	RPM	Nm	lb ft	mm	in	mm	in	kg	lb	Standard	
EB55MB4-460	220	460	339	44	1.7	564	22.2	7.4	16.3	1" SD	
EB55MB4-620	165	620	457	44	1.7	564	22.2	7.4	16.3	1" SD	
EB55MB5-800	125	800	590	48	1.9	575	22.6	9	19.8	1" SD	
EB55MB5-1100	80	1100	811	48	1.9	598	23.6	10	22	1" SD	
EB55MB5-1500	60	1500	1106	48	1.9	625	24.6	10	22	1" SD	
EB55MB5-2000	50	2000	1475	48	1.9	625	24.6	10	22	1" SD	

EB Inline Fixtured Options

EB45, EB55 (MB2 Models)

Reaction Device	Part No.
Reaction Bar, Steel	20K100200
Base Mount Bracket	20K100600
Mounting Flange-B	20K100700
3/4" SD Socket Lock Pin	Part No.
Standard	20D227800
Rounded (Ball Detent)	20D227802

EB Inline Fixtured Options

EB55MB3 Model

Reaction Device	Part No.
Reaction Bar, Steel	B4487
Base Mount Bracket	H1140
Mounting Flange-B	M4329
3/4" SD Socket Lock Pin	Part No.
Standard	20D227800
Rounded (Ball Detent)	20D227802

EB Inline Fixtured Options

EB55MB4 & 5 Models

Reaction Device	Part No.
Reaction Bar, Steel	F4192
Base Mount Bracket	F4201
Mounting Flange-B	20K101100
1" SD Socket Lock Pin	Part No.
Standard	20D227800
Rounded (Ball Detent)	20D227802

EB Series - Inline Retractable Fixtured Tools

Inline Retractable Fixtured Tools (5.6 to 250 Nm)

EB Inline Retractable Fixtured Options

3/8" Output

Output Options	Part No.
Standard	M3050
24 Threaded	M3118
24 Threaded, 3/4" Long	M3227
1-5/32" Extension	S3362
1.478" Extension	M3243
2" Extension	M3090
2-3/8" Extension	S3363
3" Extension	M3229
4" Extension	M3223
4-1/16" Extension	S3486
6" Extension	M3224
7-3/8" Extension	S3626
8" Extension	M3216
8" Extension Assembly	20S104600
Spring Options	Part No.
Standard	M4096
Heavy Duty Spring	M3184
Extra Heavy Duty Spring	20R201428

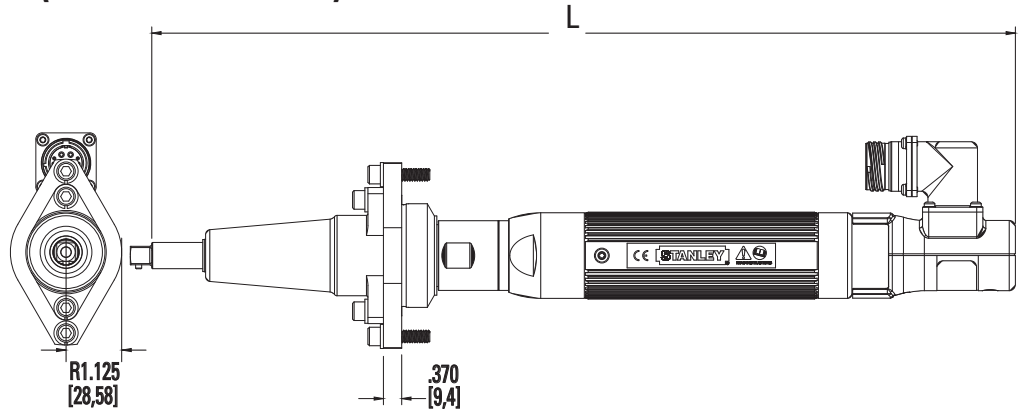

Model	Rated Speed		Torque		"R" Side to Center		"L" Length		Weight		Output	
	RPM	Nm	lb ft	mm	in	mm	in	kg	lb	Retraction	Standard	
EB33MBF1-28	1590	28	20.6	28	1.13	443	17.4	1.6	3.52	25mm 1"	9.5mm	
EB33MBF1-40	1120	40	29.5	28	1.13	443	17.4	1.6	3.52		3/8" SD	

EB Inline Retractable Fixtured Options

1/2" Output

Output Options	Part No.
Standard	20D101600
2" Extension	20D101610
3" Extension	20D101603
4" Extension	20D101608
5" Extension	20D101604
6" Extension	20D101606
7-5/16" Extension	20D101605
8" Extension	20D101609
11" Extension	20D101607
Spring Options	Part No.
Standard	B4093
Heavy Duty Spring	20R201401

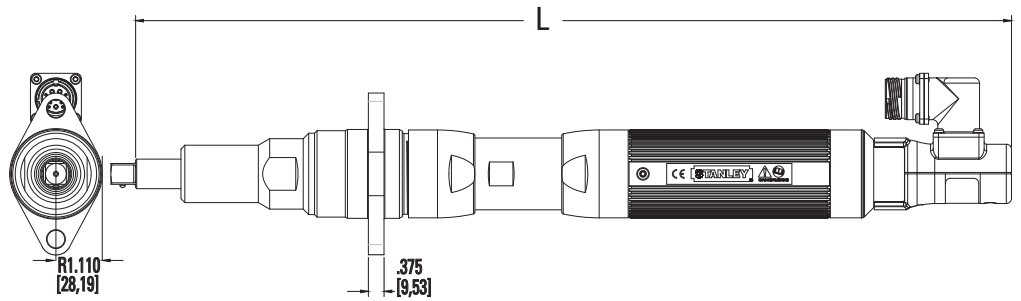

Model	Rated Speed		Torque		"R" Side to Center		"L" Length		Weight		Output	
	RPM	Nm	lb ft	mm	in	mm	in	kg	lb	Retraction	Standard	
EB34MB1F1-55	830	55	40.5	28	1.11	499	19.6	3.3	7.24	25mm 1"	13mm	
EB44MB1F1-80	895	80	59.0	28	1.11	511	20.1	3.8	8.34		1/2" SD	
EB44MB1F1-120	560	120	88.5	28	1.11	533	21.0	3.8	8.34			

EB Inline Retractable Fixtured Options

5/8" Output

Output Options	Part No.
Standard	20D102901
2" Extension	20D102912
6" Extension	20D102913
Spring Options	Part No.
Standard	20R201407
Heavy Duty Spring	20R201408

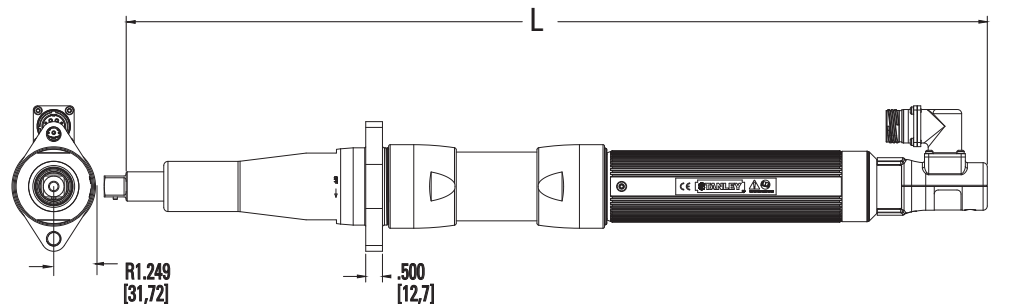

Model	Rated Speed		Torque		"R" Side to Center		"L" Length		Weight		Output	
	RPM	Nm	lb ft	mm	in	mm	in	kg	lb	Retraction	Standard	
EB45MB2F1-140	465	140	103	32	1.25	600	23.6	3.6	7.92	25mm 1"	16mm	
EB55MB2F1-170	640	170	125	32	1.25	631	24.8	4.2	9.21		5/8" SD	
EB45MB2F1-190	355	190	140	32	1.25	600	23.6	3.6	7.92			
EB55MB2F1-250	400	250	184	32	1.25	654	25.7	4.3	9.46			

Inline Retractable Fixtured Tools (64 to 2000 Nm)

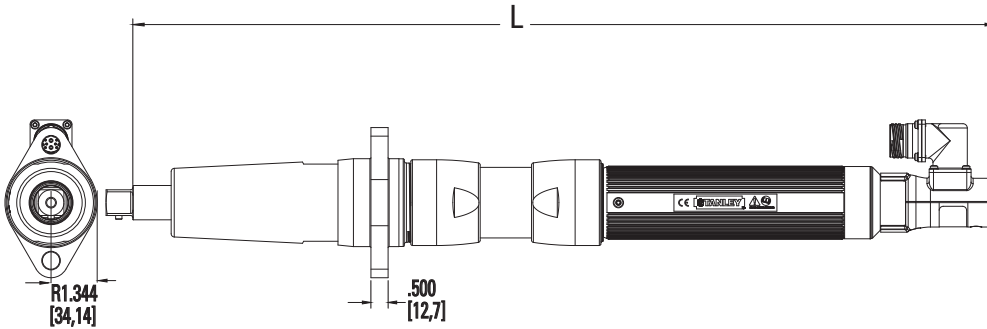

Model	Rated Speed	Torque		"R" Side to Center		"L" Length		Weight		Output	
	RPM	Nm	lb ft	mm	in	mm	in	kg	lb	Retraction	Standard
EB55MB3F1-320	310	320	236	34	1.34	636	25	6.7	14.74	25mm / 1"	19mm / 3/4" SD

EB Inline Retractable Fixtured Options

3/8" Output

Output Options	Part No.
Standard	20D102101
5" Extension	20D102106
Spring Options	Part No.
Standard	20R201403
Heavy Duty Spring	20R201404
Reaction Components	Part No.
Mounting Flange - MB3F	20D205600

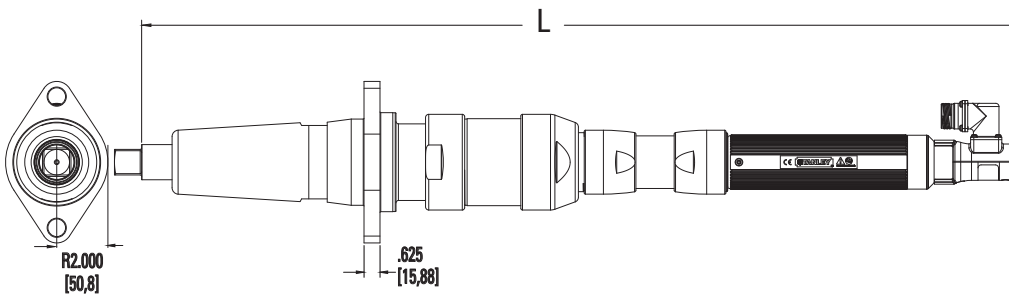

Model	Rated Speed	Torque		"R" Side to Center		"L" Length		Weight		Output	
	RPM	Nm	lb ft	mm	in	mm	in	kg	lb	Retraction	Standard
EB55MB4F1-460	220	460	339	44	1.7	803	31.6	17.2	37.84	25mm 1"	25mm 1" SD
EB55MB4F1-620	165	620	457	44	1.7	803	31.6	17.2	37.84		
EB55MB5F1-800	125	800	590	50	2	840	33.0	18.3	40.26		
EB55MB5F1-1100	80	1100	811	50	2	863	34.0	18.3	40.26		
EB55MB5F1-1500	60	1500	1106	50	2	870	34.3	19.2	42.24		
EB55MB5F1-2000	50	2000	1475	50	2	870	34.3	19.2	42.24		

EB Inline Retractable Fixtured Options

1" Output

Output Options	Part No.
Standard	20D208800
2" Extension	20D208803
4" Extension	20D208802
3/4" SD (MB4F1 ONLY)	20D121100
Reaction Components	Part No.
Mounting Flange - MB4F	20D208500
Mounting Flange - MB5F	20D209500

EB Series - Offset Retractable Fixtured Tools

Offset Retractable Fixtured Tools (5 to 108 Nm)

EB Retractable Options

EB33

Spring Options	Part No.
Standard	M3062
Heavy Duty	M3183
Output Options	Part No.
3/4" Extended Output	M3227
1-5/32" Extended Output	S3362
1.478" Extended Output	M3243
2" Extended Output	M3090
2-3/8" Extended Output	S3363
3" Extended Output	M3239
4" Extended Output	M3223
4-1/16" Extended Output	S3486
6" Extended Output	M3224
7-3/8" Extended Output	S3626
8" Extended Output	M3216
8" Extended Output, Thin	20S104600
24 Threaded Output	M3118
1/2" Square Drive Lock Pin	Part No.
Standard	20D227800
Rounded (Ball Detent)	20D227801

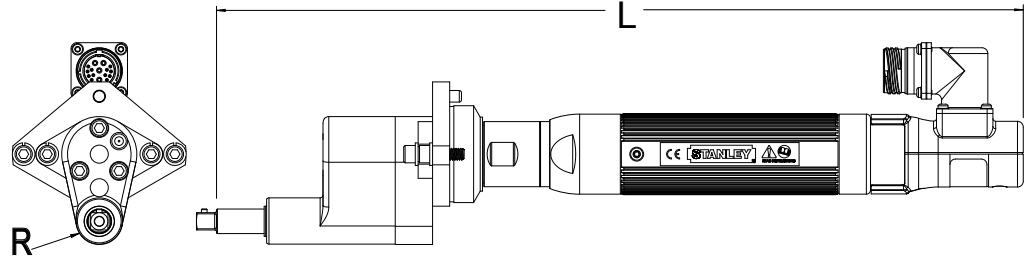

Model	Rated Speed		Torque		"R" Side to Center		"L" Length		Weight		Output	
	RPM		Nm	lb ft	mm	in	mm	in	kg	lb	Retraction	Standard
EB33MDF1-25	1590		25	18.4	13	0.51	496	19.5	2.8	6.16	19mm (3/4")	3/8"
EB33MDF1-36	1120		36	26.6	13	0.51	496	19.5	2.8	6.16		

EB Retractable Options

EB34, EB44

Spring Options	Part No.
Standard	B4093
Heavy Duty	20R201401
Output Options	Part No.
2" Extended Output	20D101610
3" Extended Output	20D101603
4" Extended Output	20D101608
5" Extended Output	20D101604
6" Extended Output	20D101606
7-5/16" Extended Output	20D101605
8" Extended Output	20D101609
11" Extended Output	20D101607
1/2" SD Socket Lock Pin	Part No.
Standard	20D227800
Rounded (Ball Detent)	20D227801

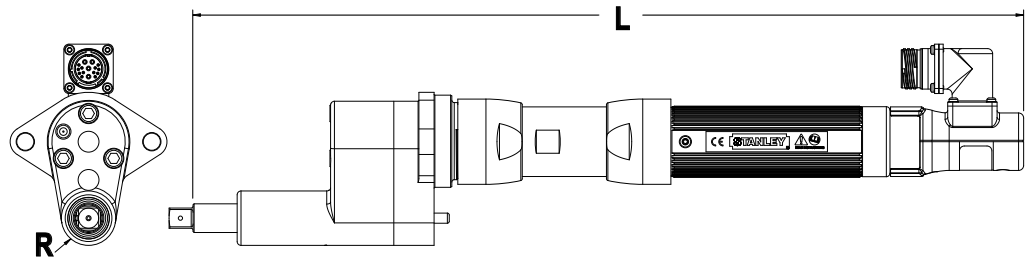

Model	Rated Speed		Torque		"R" Side to Center		"L" Length		Weight		Output	
	RPM		Nm	lb ft	mm	in	mm	in	kg	lb	Retraction	Standard
EB34MD1F1-48	830		48	35.4	13	0.51	496	19.5	4.4	9.68	25mm (1")	1/2"
EB44MD1F1-70	895		70	51.6	17	0.67	540	21.3	4.8	10.56		
EB44MD1F1-108	560		108	79.7	17	0.67	540	21.3	4.8	10.56		

Offset Retractable Fixtured Tools
(25 to 225 Nm)

EB Retractable Options

EB45, EB55

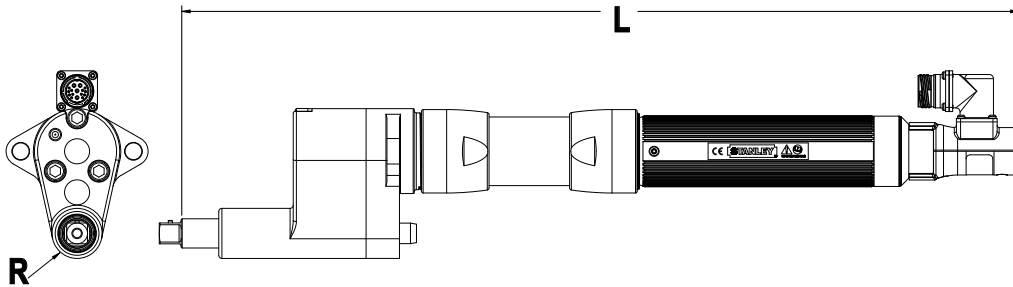

Retraction Spring	Part No.
Standard	20R201407
Heavy Duty	20R201408
Output Options	Part No.
2" Extended Output	20D102912
6" Extended Output	20D102913
3/4" SD Socket Lock Pin	Part No.
Standard	20D227800
Rounded (Ball Detent)	20D227802

Model	Rated Speed		Torque		"R" Side to Center		"L" Length		Weight		Output	
	RPM	Nm	lb ft	mm	in	mm	in	kg	lb	Retraction	Standard	
EB45MD2F1-125	465	125	92.2	17	0.67	605	23.8	10.5	23.2	25mm (1")	5/8"	
EB55MD2F1-150	640	150	111	19	0.75	656	25.8	10.5	23.2			
EB55MD2F1-225	400	225	166	19	0.75	656	25.8	10.5	23.2			

Here are some examples of how to create square or circular bolt patterns in customer supplied mounting plates for Inline and Offset Retractable tools.

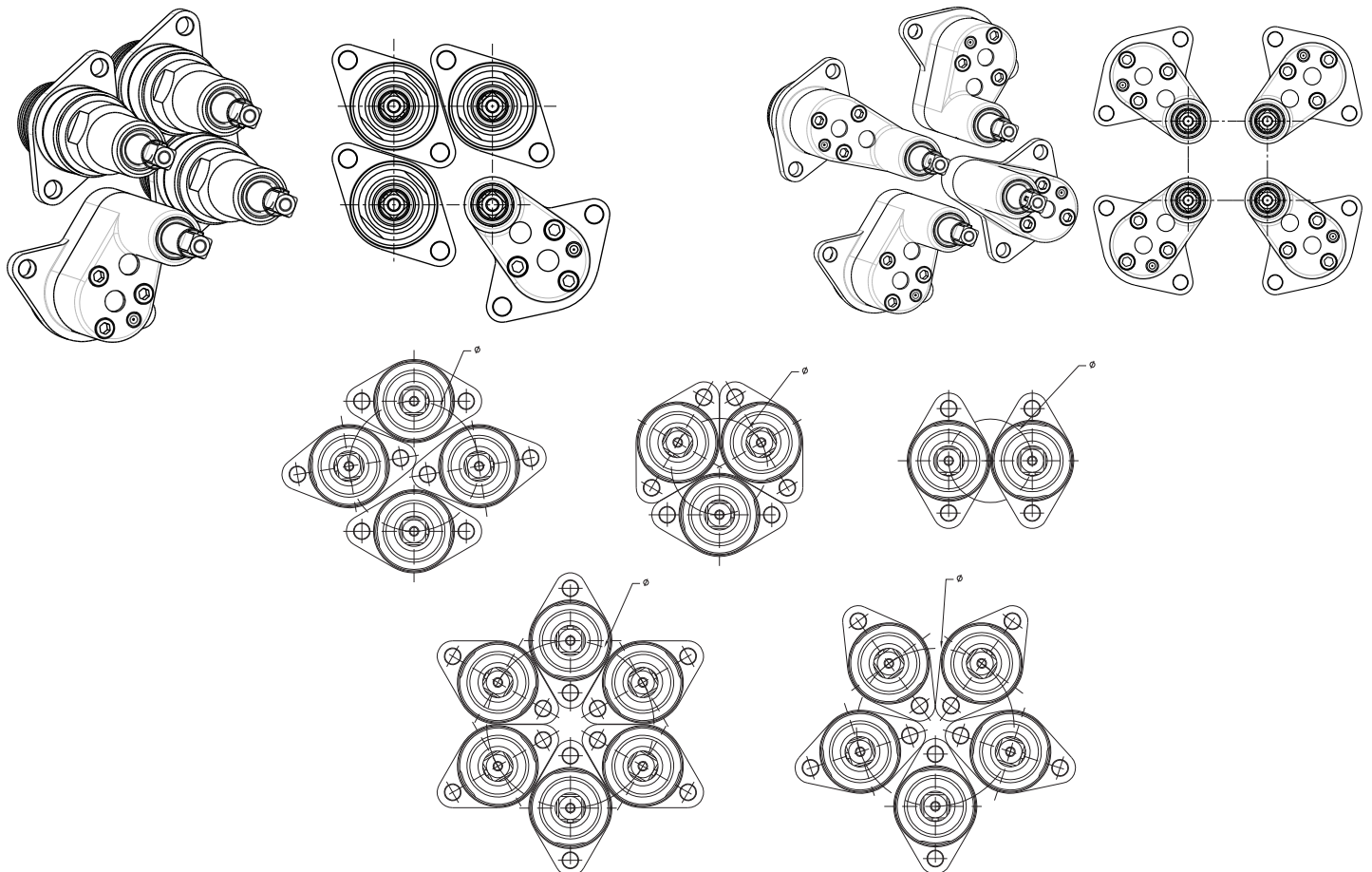

EA/ EB/ EC Series Tool Cable Options

Choose Your Cable

Step 1: Select a tool whip for the tool model

Step 2: Select an extension for the selected whip number

Note: All Hi-Flex cables have an 8cm (3in) minimum bend radius

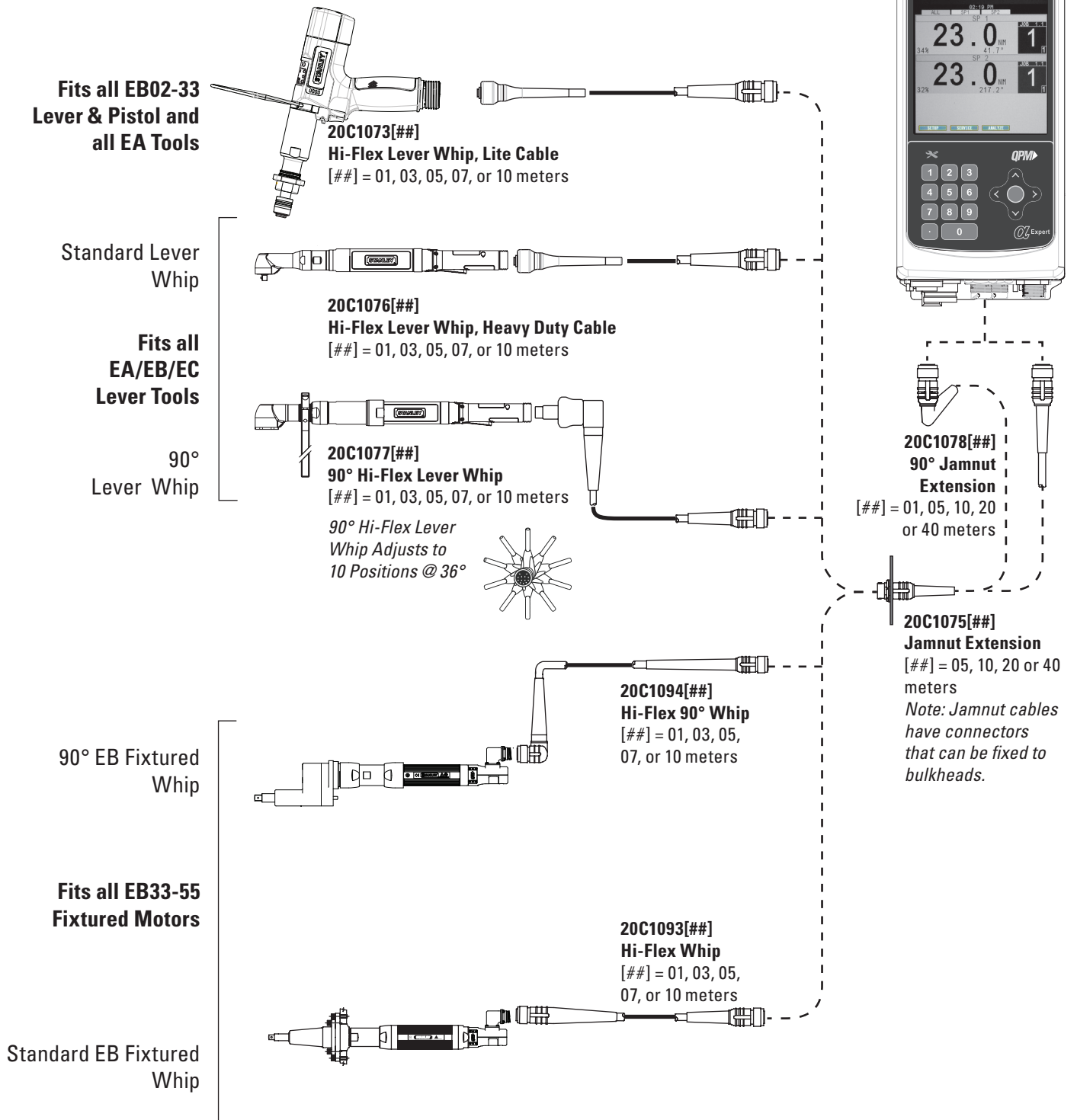

E Series Tool Cable Options

STANLEY

Step 1: Select a tool whip for the tool model

Step 2: Select an extension for the selected whip number

Note: All Hi-Flex cables have an 8cm (3in) minimum bend radius

Choose Your Cable

Fits
E12
Lever Tools



20C1046[##] High Flex E1 Lever Whip,
*##] = 01, 03, 05, 07 or 10 meters

Fits E23-34
Lever Tools

E02-34 Pistols
(Bottom Exit)

Lightweight
E3 Whip

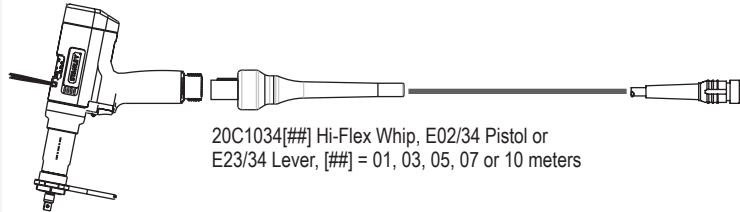

20C1034[##] Hi-Flex Whip, E02/34 Pistol or
E23/34 Lever, [##] = 01, 03, 05, 07 or 10 meters

Fits
E23-55, *E12
Lever Tools

E02-34 Pistols
(Bottom Exit)

Standard
E5 Whip

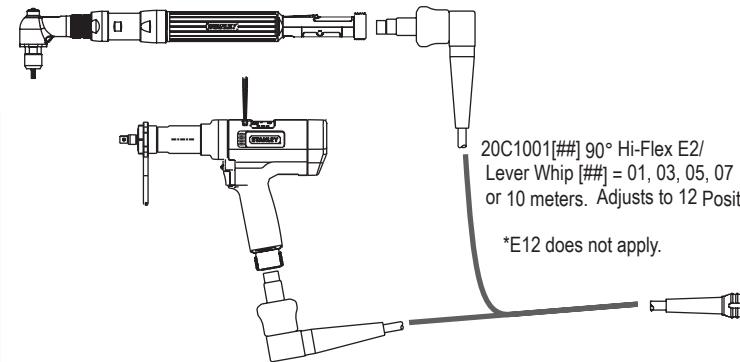

20C1001[##] 90° Hi-Flex E2/
Lever Whip [##] = 01, 03, 05, 07
or 10 meters. Adjusts to 12 Positions @ 30°

*E12 does not apply.

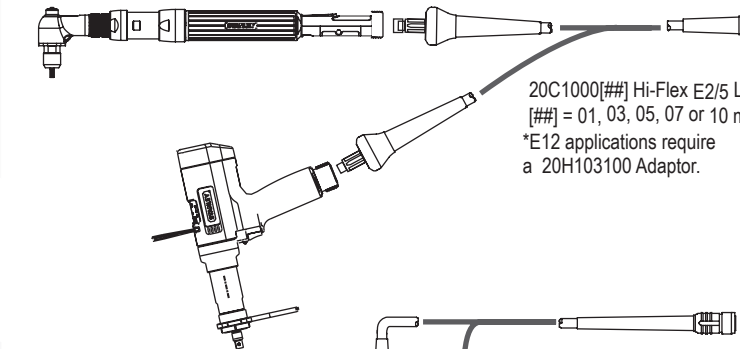

20C1000[##] Hi-Flex E2/5 Lever Whip,
[##] = 01, 03, 05, 07 or 10 meters
*E12 applications require
a 20H103100 Adaptor.

Fits
E02-34 Pistol
(Top Exit)

E23-55
Moving
Fixtured Motors

Standard
E5 Whip

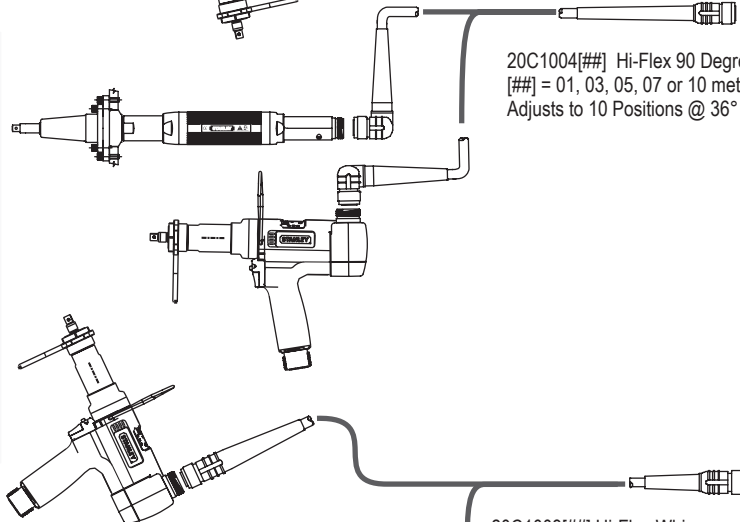

20C1004[##] Hi-Flex 90 Degree Whip
[##] = 01, 03, 05, 07 or 10 meters @ Tool
Adjusts to 10 Positions @ 36°

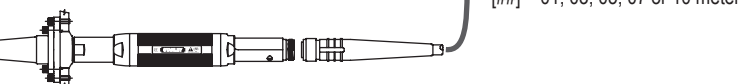

20C1003[##] Hi-Flex Whip
[##] = 01, 03, 05, 07 or 10 meters



20C1011[##] 90 Degree
Jamnut Extension
[##] = 05, 10,
or 20 meters

20C1002[##] Jamnut
Extension [##] =
05, 10, or 20 meters

NOTE:
Jamnut cables
have connectors
that can be fixed to bulkheads.

Complete Engineered Systems Solutions

Engineered Systems Solutions

Single and multi-spindle systems include the complete line of STANLEY pneumatic and DC electric assembly tools. Available features include spindle synchronization, cycle complete operation, absorption of reaction torque and operator feedback with error-proofing options. A complete line of torque tubes and articulating arm systems can balance loads to 500 pounds and maintain torque reaction to 5,000 Nm.

Custom solutions are matched to unique assembly needs using extensive engineering experience, a complete line of assembly spindles, process controllers and tightening strategies. Some examples are flywheel indexing, wheel bearing end play, articulated jibs, shear bolt assembly and high torque crowfoot tools. STANLEY also builds full and semi-automated systems, as well as offline subassembly stations.



Engineered Systems capabilities include custom design and build services, joint analysis, total project management, installation, start-up services and technical support. Our engineers are experts in evaluating your needs and converting them into solutions that improve the productivity, ergonomics and quality of your manufacturing operations. Armed with the skills to anticipate and prevent potential problems, STANLEY designs systems on which you can rely to deliver the performance and reliability you demand.



World-Class Technical Support

As a supplier to the assembly market, STANLEY has developed a global sales and service network to support the manufacturing operations of our customers. STANLEY offers many levels of customer support, from basic maintenance and operator training to full service repair facilities and maintenance service contracts.



Our Engineered System Solutions can help you achieve breakthrough improvements in productivity, quality and ergonomics.



Accountability - From Turnkey Systems to Components & Support

STANLEY can design custom tailored solutions that meet the specific requirements of your application, your site, and your company's design standards and specifications.

A customer approving their system before shipment.

Productivity - System Optimization Reduces Cycle Times

- Synchronous tightening strategies enable simultaneous assembly using multiple spindle configurations
- Automated and semi-automated tool handling reduces labor
- Faster tools reduce rundown time
- System design optimizes operator motion

Quality - Increase And Verify Assembly Quality

- Error proofing ensures complete assembly
- Data collection and interface with plant control systems
- Multi-step and sequenced rundowns use specialized fastening control strategies
- Bar coding enables traceability

Ergonomics - Torque Reaction Design Expertise

- Ergonomic solutions improve worker productivity at reduced strain levels
- High-torque applications (up to 5,000 Nm)

Return on Investment - Lower Total Cost of Ownership

- Lowered costs on materials and labor
- Reduced times for setup, fastening, rework and maintenance
- Increased quality, productivity, ergonomics and flexibility

STANLEY Components & Support Services

STANLEY supports internal project managers with the capability needed for their installations, including tools and controllers, floor-mounted subassembly systems, tool and product handling components, cable management, low cost fixtured kits and other accessories. Support Services include installation supervision, startup support, refurbishment, on and off site calibration, as well as training and field service/ repair.

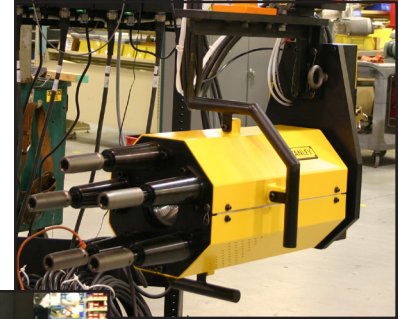

Multi-spindle tools significantly reduce assembly time.



Bolt holding tools reduce labor requirements and speed assembly.

Flywheel indexing tools ensure quality with bolt-count error proofing.

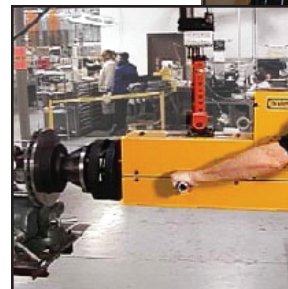
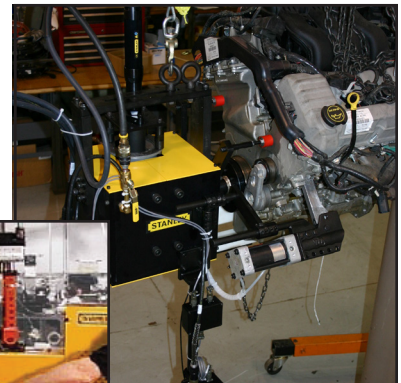

Wheel bearing end play tools achieve improved tolerances.

Tabletop articulated arm ss improve ergonomics and reduce strain.

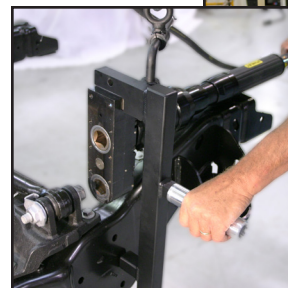
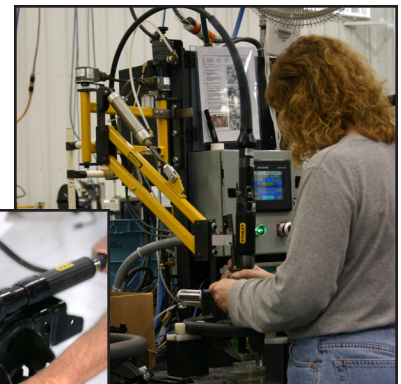

Engineered Systems - Turnkey System Design

Comprehensive Project Management from Proposal to Customer Approval

STANLEY offers these important advantages:

- A menu of standard and customized solutions apply to a wide range of applications
- Integrated supplier (all tools, controllers, accessories, etc. + design and installation/ support services from a single source) for assured, seamless system integration
- Full project management accountability with single point contact

Typical Project Milestones:

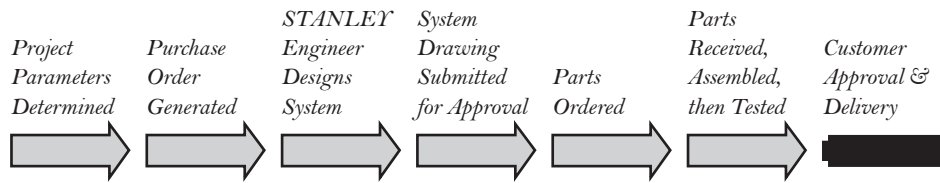

STANLEY Turnkey Solutions:

- Application engineering
- Comprehensive system design capabilities including estimates, specification, manufacturing, and flexible component sourcing
- Project scheduling
- System integration
- Installation/ Startup
- PLC Software, custom ladder
- Documentation
- Training

STANLEY Solutions In Action - Multi-Spindle Fixtured Tools

Semi-Automation

Off road final drive assembly machine

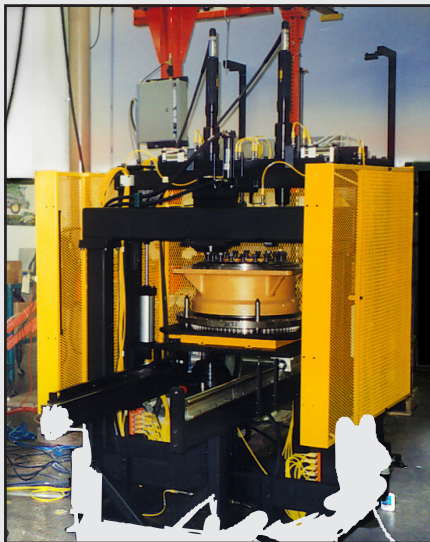

- 3 station assembly operation:
 - Hydraulic press
 - Digital measurement
 - Fastener secure
- Part indexing, bolt spacing and configurations for distinct assemblies
- Custom controls integrate to plant network
- All controls and design to customer specs

Trunnion

Secures fasteners in randomly oriented bolt circle

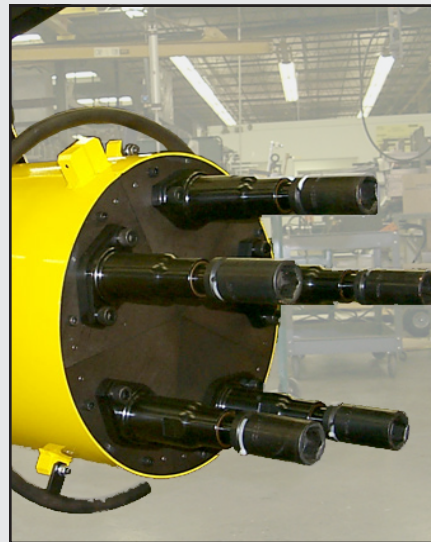

- Trunnion rotates to align tools with fasteners
- Torque recovery strategies available for wheelnut secure installations
- Multiple spindle systems absorb torque reaction
- Automatic "bias-in", kick-off", and headlight options available

Bolt-Holding

Holds bolt stationary while securing nut



- Reactionless operation reduces injuries
- Semi-automatic rundown
- Cycle complete operation eliminates external influence
- Multiple spindle options available

Control Strategies Tailored To Fit Your Applications

Whether your tightening applications require a single strategy for assembly to a target torque level or a series of strategies that can monitor material properties and/ or component position, STANLEY gives you the control you need. Each strategy consists of a complete set of parameters to control and/ or audit torque, angle, time, speed and power. Multiple strategies advance in sequence, invisible to the operator, or pause the tool briefly to manage direction changes, multiple spindle synchronization or relaxation and crosstalk effects.

Example Control Strategies

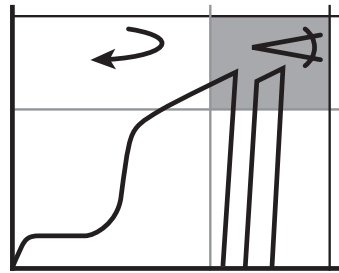

Torque Recovery overcomes crosstalk on multiple spindles.

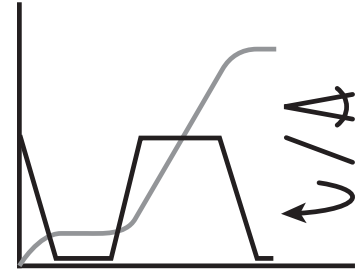

Yield Control strategies sense change in torque versus angle rate.

STANLEY Solutions In Action - Custom Configurations

High-Torque Crowfoot Tools

Capacities to 1,800 Nm

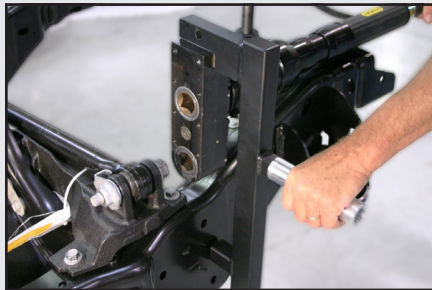

- Special tool geometry accesses close clearance fasteners
- Fixturing absorbs torque reaction impulse

Wheel Bearing End-Play

Multi-step strategy achieves end play spec

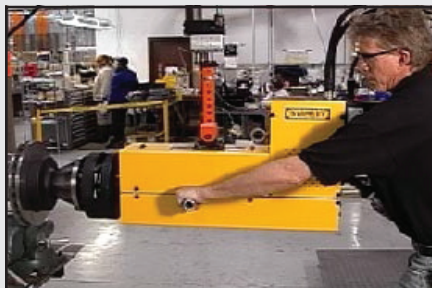

- Reduces warranty costs with controlled fastening sequence
- Elimination of hand tools improves ergonomics
- Continuous counter clockwise rotation of hub ensures bearing seating

Flywheel Indexer

Secures torque converter to flywheel

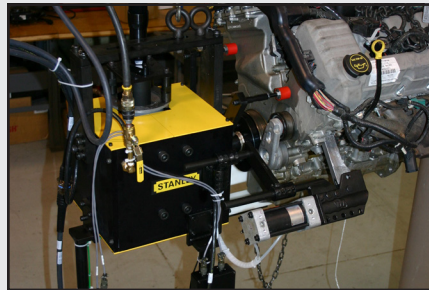

- Automatically indexes flywheel for each bolt to be tightened
- Bolt count error proofing ensures quality
- Reduces labor

Shear Bolt

Reactionless tightening of shear bolts



- Cannot overtighten bolts
- Eliminates need for back-up wrench
- Eliminates need for second operator
- Visual inspection: when tip is gone, clamp load is achieved

Articulated Arms & Jibs



- Tool/ product weigh supported, reducing weight handled by operators
- Tools/ loads easier to manipulate
- Absorbs torque reaction to prevent operator strain

Many other custom solutions are available. Contact your STANLEY Engineered Systems expert to discuss the solution that best fits your application.



QPM Threaded Fastening Solutions

With torque capacity ranging from 0.5 to 2000 Nm, STANLEY QPM threaded fastening solutions come in multiple geometries and fit the most critical assembly requirements. Real time monitoring, analysis, diagnostics and configurations are available plant wide, with networked controls.



Cable routing/ festooning kits

Ask us about our festooning kits.

STANLEY System Components Include

- Tools
- Controllers
- Power Modules
- Floor Mounted Subassembly Systems
- Tool/ Product Handling Components
 - Torque Tubes
 - Arms
 - Balancers
 - Rails
- Cable Management/ Festooning Kits
- Low-cost fixtured kits for basic assembly needs
- Accessories

480V AC Power Modules for QPM Systems

- 3.4, 7.5, 12 and 24kVA transformers deliver consistent 220V AC output to each receptacle
 - One receptacle is always "live"
 - Alpha receptacles controlled by E-Stop circuit
 - All receptacles protected with 10A circuit breakers
- Extended I/O Capability
 - Allen-Bradley compact block I/O available (uses DeviceNet for communication)
 - Built-in 24VDC power supply, rated @ 2A for discreet I/O
 - 72-PIN Harting connector for discreet I/O
- Lockable, knife-edge disconnect with emergency stop button to disable all modules
- Available floor stand with mounting plate for easy installation of all modules
- Cabinet is NEMA-12 rated
- UL/ CSA Approved option

Networking & Error Proofing Solutions

- Manage as many as 24 assembly tools
- Internal soft PLC for custom process control
- Ethernet, Fieldbus or serial communication

SVB Vertical Balancers - Clevis Interface

Max Balancing Capacity @ 65 psi: 34 kg (75 lb) to 277 kg (610 lb)

Vertical Balancers maintain vertical position with horizontal movement for tools without torque reaction impulse such as multiple spindle nutrunners or material handling end effectors. Standard configurations range in vertical travel from 15 to 91cm (6 to 36 in) and balancing capacity from 34 to 277 kg (75 to 610 lb). Custom travel distances and balancing capacities are available. Specify vertical travel "V" from 15 to 91cm (6 in to 36 in).

- Zero-gravity tool balancing reduces operator fatigue
- All critical fasteners are either safety wired or pinned to ensure reliable operation
- Rugged and simple construction
- Single trolley interfaces with common overhead rails

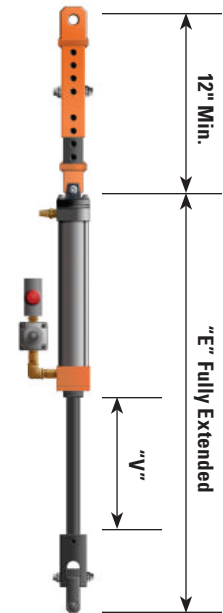

Includes Suspension Trolley

Model Number Build			
SVB	###	X	##

Cylinder Size			"E" + 2"V"	
kg	in		cm	in
34	75	150	27.6	10.9
55	120	200		
97	215	250	29	11.4
176	390	325	32	12.6
277	610	400		

	"V" Vertical Travel	
	cm	in
6	15	6
12	30	12
18	46	18
24	60	24
30	76	30
36	91	36

Trolley Suspension	
4" I-Beam Trolley	A
6" I-Beam Trolley	B
3.25" or 3.33" Flat Track Trolley	C
Unified ETA-4 Trolley	D
Unified ETA-8 Trolley	E
Demag KBKI Trolley	F
Demag KBKII-L Trolley	G
IR/Zimmerman Trolley ZRA1	H
IR/Zimmerman Trolley ZRA2	I

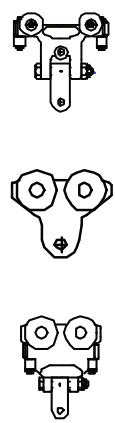
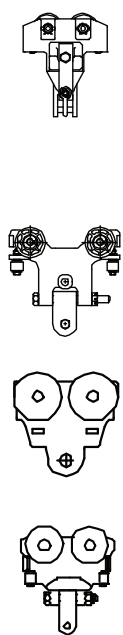

- Options:
- Special Tool Holders and Interfaces
 - Dual and Triple Balance Air Logic
 - Dual Trolleys

Engineered Systems - Light Duty Torque Tubes

STT075 Light Duty Torque Tubes

Max Torque: 135 Nm (100 ftlb)

Max Balancing Capacity @ 65 psi: 24 kg (55 lb)

STT075 Light Duty Torque Tubes offer zero-gravity balancing and absorb the torque reaction for nutrunner applications to 135 Nm (100 ftlb). A rugged design has balancing capacity for single or multiple spindle nutrunners to 34 kg (75 lb). The torque tube protects the operator from nutrunner torque reaction impulse. Fixtured tool orientation increases fastening accuracy and consistency. Specify vertical travel "V" from 15 to 60 cm (6 to 24 in). Custom travel distances and balancing capacities are available.

- **Zero-gravity tool balancing and elimination of torque reaction exposure reduces operator fatigue**
- **Either swivel or fixed tool interface, clevis interface optional**
- **Single or dual trolley suspension with common overhead rails**

Options:

- Special Tool Holders and Interfaces
- Dual and Triple Balance Air Logic
- Dual Bridges
- Other Trolleys including Anti-kickup
- Clevis STT075CL

*Includes
Suspension
Trolley*

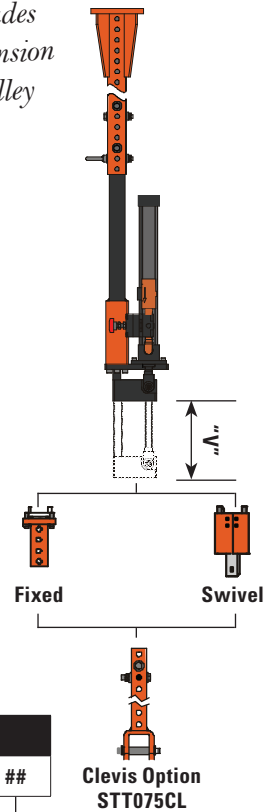

Model Number Build						
STT	075	XX	150	X or XX		##

Tool Interface		
	Fixed	FX
	Swivel	SW

"V" Vertical Travel		
	cm	in
6	15	6
12	30	12
18	46	18
24	60	24

	Single Trolley	Trolley Suspension	Dual Trolley
	A	4" I-Beam Trolley	AA
	B	6" I-Beam Trolley	BB
	C	3.25" or 3.33" Flat Track Trolley	CC
	D	Unified ETA-4 Trolley	DD
	E	Unified ETA-8 Trolley	EE
	F	Demag KBKI Trolley	FF
	G	Demag KBKII-L Trolley	GG
	H	IR/Zimmerman Trolley ZRA1	HH
	I	IR/Zimmerman Trolley ZRA2	II

Note: Single Trolleys not recommended for torque reaction applications.

STT100 Medium Duty Torque Tubes

Max Torque: 270 Nm (200 ftlb)

Max Balancing Capacity @ 65 psi: 56 kg (125 lb) or 90 kg (200 lb)

STT100 Medium Duty Torque Tubes offer zero-gravity balancing and absorb the torque reaction for nutrunner applications to 270 Nm (200 ftlb). A rugged design, suitable for line tracking, has balancing capacity for single or multiple spindle nutrunners to 56 kg (125 lb) or 90 kg (200 lbs). The torque tube protects the operator from nutrunner torque reaction impulse. Fixtured tool orientation increases fastening accuracy and consistency. Specify vertical travel "V" from 15 to 60 cm (6 to 24 in). Custom travel distances and balancing capacities are available.

- Zero-gravity tool balancing and elimination of torque reaction exposure reduces operator fatigue
- Either swivel or fixed tool interface, clevis interface optional
- Single or dual trolley suspension with common overhead rails

Options:

- Special Tool Holders and Interfaces
- Dual and Triple Balance Air Logic
- Dual Bridges
- Other Trolleys including Anti-kickup
- Clevis STT100CL

*Includes
Suspension
Trolley*

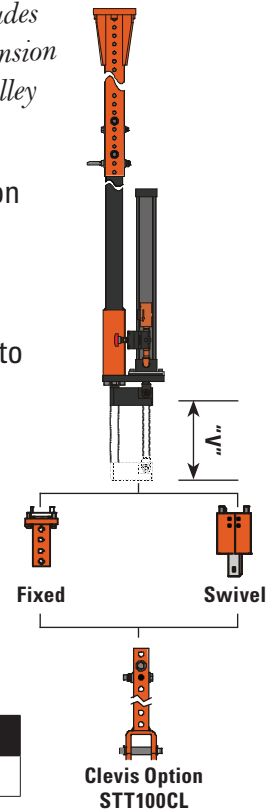

Model Number Build						
STT	100	XX	150	###	X or XX	##

Tool Interface		
	Fixed	FX
	Swivel	SW

	Cylinder Size	
	kg	lb
200	56	125
250	90	200

	"V" Vertical Travel	
	cm	in
6	15	6
12	30	12
18	46	18
24	60	24

	Single Trolley	Trolley Suspension	Dual Trolley
	A	4" I-Beam Trolley	AA
	B	6" I-Beam Trolley	BB
	C	3.25" or 3.33" Flat Track Trolley	CC
	D	Unified ETA-4 Trolley	DD
	E	Unified ETA-8 Trolley	EE
	F	Demag KBKI Trolley	FF
	G	Demag KBKII-L Trolley	GG
	H	IR/Zimmerman Trolley ZRA1	HH
	I	IR/Zimmerman Trolley ZRA2	II

Note: Single Trolleys not recommended for torque reaction applications.

Engineered Systems - Heavy Duty Torque Tubes

STT125 Heavy Duty Torque Tubes

Max Torque: 677 Nm (500 ftlb)

Max Balancing Capacity @ 65 psi: 75 kg (175 lb) or 150 kg (350 lb)

STT125 Heavy Duty Torque Tubes offer zero-gravity balancing and absorb the torque reaction for nutrunner applications to 677 Nm (500 ftlb). A rugged design, suitable for line tracking, has balancing capacity for single or multiple spindle nutrunners to 75 kg (175 lb) or 150 kg (350 lbs). The torque tube protects the operator from nutrunner torque reaction impulse. Fixtured tool orientation increases fastening accuracy and consistency. Specify vertical travel "V" from 15 to 90 cm (6 to 36 in). Custom travel distances and balancing capacities are available.

- Zero-gravity tool balancing and elimination of torque reaction exposure reduces operator fatigue
- Either swivel or fixed tool interface, clevis interface optional
- Single or dual trolley suspension with common overhead rails



Options:

- Special Tool Holders and Interfaces
- Dual and Triple Balance Air Logic
- Dual Bridges
- Other Trolleys including Anti-kickup
- Clevis STT125CL

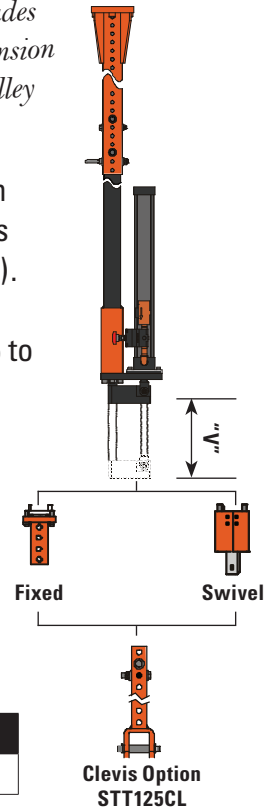
*Includes
Suspension
Trolley*









Model Number Build						
STT	125	XX	150	###	X or XX	##

Tool Interface		
	Fixed	FX
	Swivel	SW

	Cylinder Size	
	kg	lb
250	75	175
325	150	350

	"V" Vertical Travel	
	cm	in
6	15	6
12	30	12
18	46	18
24	60	24
36	90	36

	Single Trolley	Trolley Suspension	Dual Trolley
	A	4" I-Beam Trolley	AA
	B	6" I-Beam Trolley	BB
	C	3.25" or 3.33" Flat Track Trolley	CC
	D	Unified ETA-4 Trolley	DD
	E	Unified ETA-8 Trolley	EE
	F	Demag KBKI Trolley	FF
	G	Demag KBKII-L Trolley	GG
	H	IR/Zimmerman Trolley ZRA1	HH
	I	IR/Zimmerman Trolley ZRA2	II

Arm Selection

1. Select an arm model with the required balancing capacity for the job. For single nutrunners, verify the torque capacity
2. Check that the "Vertical Travel", "Reach", "D" and "F" dimensions meet the requirements of the job. Use the overhead diagram for the noted models and variables such as offset arms or mounting type
3. Select any required options

Articulating Arms

Duty Level	Arm Model	Max Torque	Balancing Capacity	Vertical Travel	Mount Type	Reach @ Torque Zero / Max	
		<i>ftlb</i>	<i>lb</i>	<i>in</i>		<i>in</i>	<i>in</i>
Light	TLA-30	50	25	7	Clevis	36	29
	THA-48	150	40	16		51	41
	LAC	200	155 - 35	12 - 30		36 - 96	29 - 77
Medium	MAC	500	190 - 30	14 - 36	Swivel	36 - 132	29 - 106
	MAS					36 - 152	29 - 125
Heavy	HAS	1000	345 - 30				

Duty Level	Arm Model	Max Torque	Balancing Capacity	Vertical Travel	Mount Type	Reach @ Torque Zero / Max	
		<i>Nm</i>	<i>Kg</i>	<i>cm</i>		<i>cm</i>	<i>cm</i>
Light	TLA-30	68	12	17	Clevis	91.6	73.6
	THA-48	205	17	406		129.5	104
	LAC	275	71 - 16	31 - 76		91 - 243	73 - 195
Medium	MAC	675	87 - 13	36 - 91	Swivel	91 - 335	73 - 269
	MAS					91 - 386	73 - 317
Heavy	HAS	1356	157 - 13				

Additional Cost Options

Offset Arm	End of Arm Swivel	Swivel w/Brake	Tool Holders
Yes	Yes	Yes	Yes

Offset Arm	End of Arm Swivel	Swivel w/Brake	Tool Holders
Yes	Yes	Yes	Yes

Standard Arm Coverage Symmetric about the outside radius

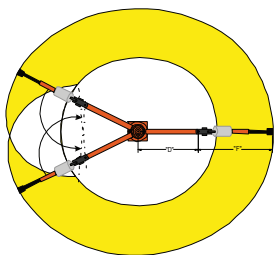

Clevis Mount Enables 220° rotation of the articulating arm assembly.
Models: TLA, THA, LAC, MAC

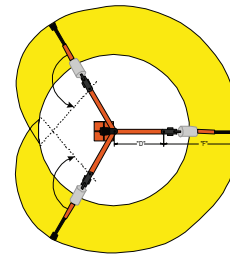

Swivel Mount Enables 360° rotation of the articulating arm assembly. Models: MAS, HAS

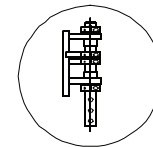

End of Arm Swivel

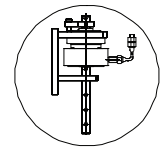

End of Arm Swivel with Brake

Offset Arm Coverage Enables coverage of the interior area by folding inward.

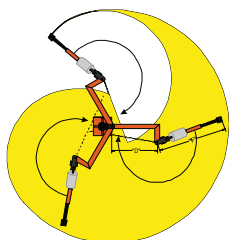

Clevis Mount Enables 220° rotation of the articulating arm assembly.
Models: LAC, MAC

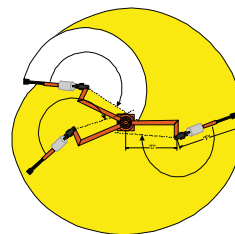

Swivel Mount Enables 360° rotation of the articulating arm assembly. Models: MAS, HAS

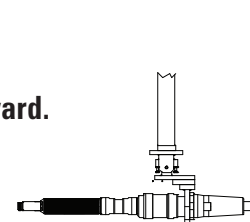

Straight Tool

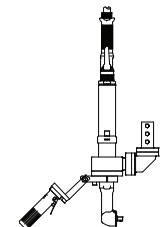

Angle Tool with Remote Start Handle

Engineered Systems - Articulating Arms

TLA-30 Light Duty Table Mounted Articulating Arm
Max Torque: 68 Nm (50 ftlb)
Max Balancing Capacity @ 65 psi: 12 kg (25 lb)

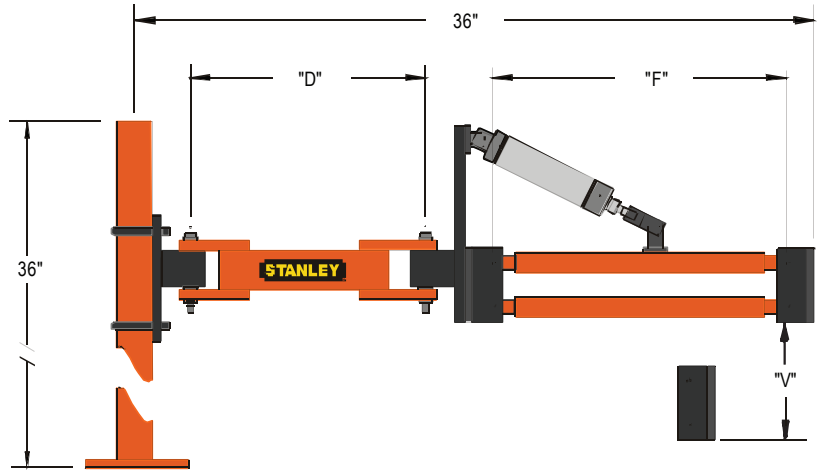

THA-48 Heavy Duty Table Mounted Articulating Arm
Max Torque: 205 Nm (150 ftlb)
Max Balancing Capacity @ 65 psi: 17 kg (40 lb)

- Ergonomics Improve Operator Interface
- Zero-gravity tool balancing and elimination of torque reaction exposure reduces operator fatigue
- Increases Fastening Accuracy and Consistency
- Eliminates operator effects on results by absorbing the torque reaction impulse

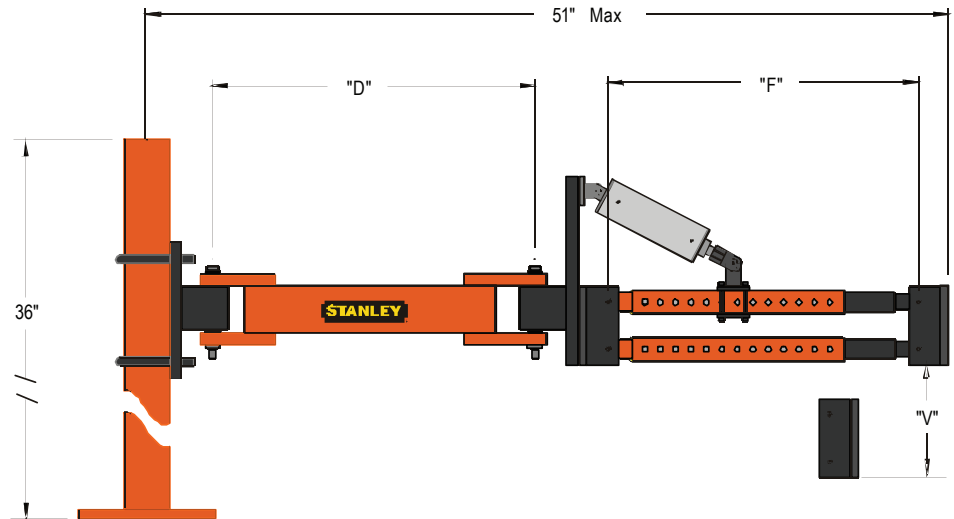

Model	"D" Length		"F" Length		"V" Travel		Max Torque		Balancing Capacity	
	mm	in	mm	in	mm	in	Nm	ftlb	kg	lb
TLA-30	305	12	381	15	177	7	68	50	12	25
THA-48	305	12	229 - 342	9 - 13.5	406	16	205	150	17	40

Options:

- End of Arm Swivel
- End of Arm Swivel with Brake (THA-48 only)
- Special Tool holders and Interfaces
- Floor Mounted Pedestals
- Overhead Bridge

LAC Light Duty Articulating Arm - Clevis Mount

Max Torque: 275 Nm (200 ftlb)

Max Balancing Capacity @ 65 psi: 41 kg (90 lb) or 71 kg (155 lb)

LAC Light Duty Articulating Arm offers interfaces for overhead bridge, floor pedestal or special mounting.

- Ergonomics Improve Operator Interface
- Zero-gravity tool balancing and elimination of torque reaction exposure reduces operator fatigue
- Increases Fastening Accuracy and Consistency
- Eliminates operator effects on results by absorbing the torque reaction impulse
- Features Ensure Reliable Operation
- All critical fasteners are either safety wired or pinned

- Options:
- Special Toolholders and Interfaces
 - End of Arm Swivel or Swivel with Brake
 - Offset Arm
 - Inverted Forearm and Cylinder
 - Dual and Triple Balance Air Logic

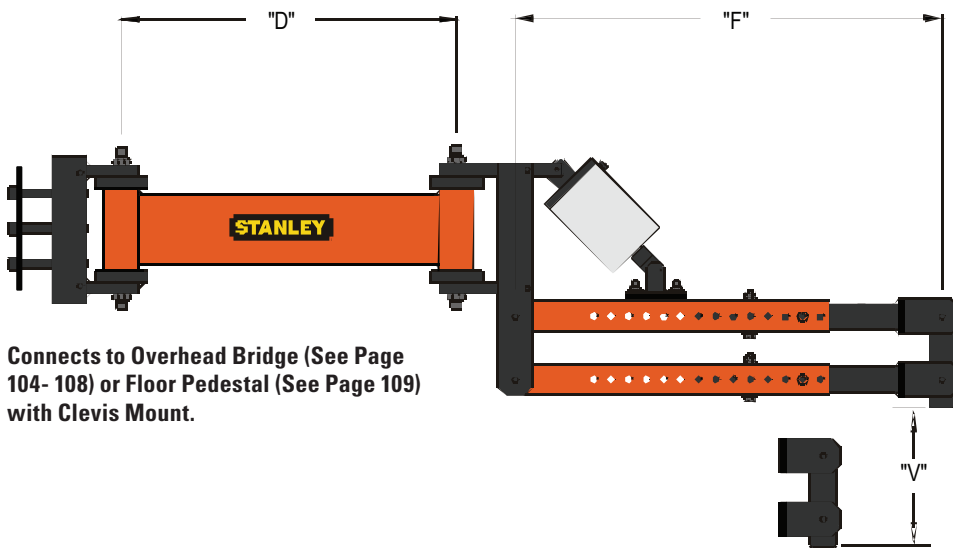

Connects to Overhead Bridge (See Page 104- 108) or Floor Pedestal (See Page 109) with Clevis Mount.

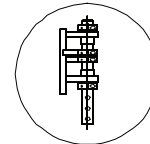

End of Arm Swivel

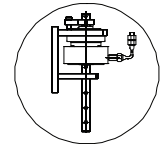

End of Arm Swivel with Brake

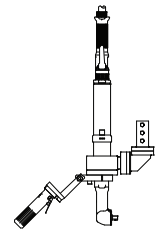

Angle Tool with Remote Start Handle

Model Number Build			
LAC	##	B or C	##

"F" Forearm Length		"V" Vertical Travel		
cm	in	cm	in	
61	24	31	12	24
76	30	38	15	30
91	36	46	18	36
107	42	53	21	42
122	48	61	24	48
137	54	69	27	54
152	60	76	30	60

B (2.5")		C (3")	
Cylinder Size			
Max Balancing Capacity			
kg	lb	kg	lb
41	90	71	155
33	70	57	125
27	60	47	105
23	50	40	90
20	45	35	75
18	40	31	70
16	35	22	50

	"D" Dumbbell Length	
	cm	in
12	30	12
18	46	18
24	60	24
30	76	30
36	91	36

Note: Capacity @ 65 psi

Engineered Systems - Articulating Arms

MA Medium Duty Articulating Arm - Clevis Mount (MAC)

Max Torque: 675 Nm (500 ftlb)

Max Balancing Capacity @ 65 psi: 42 kg (70 lb) or 87 kg (190 lb)

MA Medium Duty Articulating Arm offers interfaces for overhead bridge, floor pedestal or special mounting.

- Ergonomics Improve Operator Interface
- Zero-gravity tool balancing and elimination of torque reaction exposure reduces operator fatigue
- Increases Fastening Accuracy and Consistency
- Eliminates operator effects on results by absorbing the torque reaction impulse
- Features Ensure Reliable Operation
- All critical fasteners are either safety wired or pinned
- Safety check valves maintain load position if a sudden loss of supply air pressure occurs

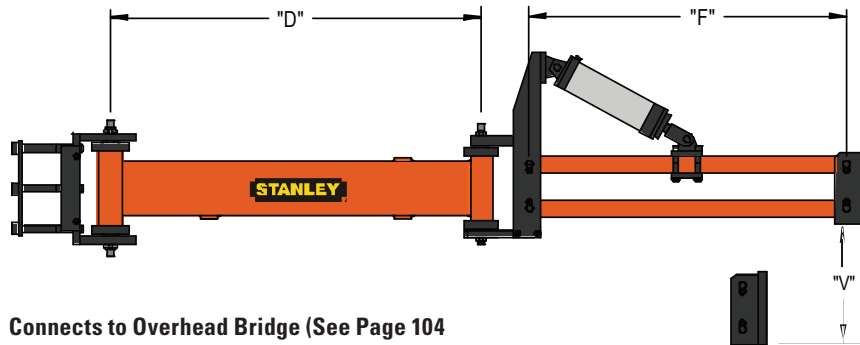

Connects to Overhead Bridge (See Page 104 - 108) or Floor Pedestal (See Page 109) with Clevis Mount.

Model Number Build																																																																					
MA	C or S	##			A, B or C			##																																																													
<table border="1"> <thead> <tr> <th colspan="2">Mounting Type</th> <th></th> </tr> </thead> <tbody> <tr> <td>Clevis</td> <td>C</td> <td></td> </tr> <tr> <td>Swivel</td> <td>S</td> <td></td> </tr> </tbody> </table>										Mounting Type			Clevis	C		Swivel	S																																																				
Mounting Type																																																																					
Clevis	C																																																																				
Swivel	S																																																																				
<table border="1"> <thead> <tr> <th colspan="2">"F" Forearm Length</th> <th colspan="2">"V" Vertical Travel</th> <th></th> </tr> <tr> <th>cm</th> <th>in</th> <th>cm</th> <th>in</th> <th></th> </tr> </thead> <tbody> <tr> <td>61</td> <td>24</td> <td>31</td> <td>12</td> <td>24</td> </tr> <tr> <td>76</td> <td>30</td> <td>38</td> <td>15</td> <td>30</td> </tr> <tr> <td>91</td> <td>36</td> <td>46</td> <td>18</td> <td>36</td> </tr> <tr> <td>107</td> <td>42</td> <td>53</td> <td>21</td> <td>42</td> </tr> <tr> <td>122</td> <td>48</td> <td>61</td> <td>24</td> <td>48</td> </tr> <tr> <td>137</td> <td>54</td> <td>69</td> <td>27</td> <td>54</td> </tr> <tr> <td>152</td> <td>60</td> <td>76</td> <td>30</td> <td>60</td> </tr> </tbody> </table>										"F" Forearm Length		"V" Vertical Travel			cm	in	cm	in		61	24	31	12	24	76	30	38	15	30	91	36	46	18	36	107	42	53	21	42	122	48	61	24	48	137	54	69	27	54	152	60	76	30	60															
"F" Forearm Length		"V" Vertical Travel																																																																			
cm	in	cm	in																																																																		
61	24	31	12	24																																																																	
76	30	38	15	30																																																																	
91	36	46	18	36																																																																	
107	42	53	21	42																																																																	
122	48	61	24	48																																																																	
137	54	69	27	54																																																																	
152	60	76	30	60																																																																	
<table border="1"> <thead> <tr> <th colspan="6">Cylinder Size Max Balancing Capacity</th> </tr> <tr> <th colspan="2">A (2")</th> <th colspan="2">B (2.5")</th> <th colspan="2">C (3")</th> </tr> <tr> <th>kg</th> <th>lb</th> <th>kg</th> <th>lb</th> <th>kg</th> <th>lb</th> </tr> </thead> <tbody> <tr> <td>32</td> <td>70</td> <td>53</td> <td>115</td> <td>87</td> <td>190</td> </tr> <tr> <td>26</td> <td>55</td> <td>43</td> <td>95</td> <td>70</td> <td>155</td> </tr> <tr> <td>22</td> <td>45</td> <td>35</td> <td>75</td> <td>55</td> <td>120</td> </tr> <tr> <td>19</td> <td>40</td> <td>30</td> <td>65</td> <td>49</td> <td>110</td> </tr> <tr> <td>16</td> <td>35</td> <td>26</td> <td>55</td> <td>43</td> <td>95</td> </tr> <tr> <td>14</td> <td>30</td> <td>23</td> <td>50</td> <td>38</td> <td>95</td> </tr> <tr> <td>13</td> <td>30</td> <td>21</td> <td>45</td> <td>35</td> <td>75</td> </tr> </tbody> </table>										Cylinder Size Max Balancing Capacity						A (2")		B (2.5")		C (3")		kg	lb	kg	lb	kg	lb	32	70	53	115	87	190	26	55	43	95	70	155	22	45	35	75	55	120	19	40	30	65	49	110	16	35	26	55	43	95	14	30	23	50	38	95	13	30	21	45	35	75
Cylinder Size Max Balancing Capacity																																																																					
A (2")		B (2.5")		C (3")																																																																	
kg	lb	kg	lb	kg	lb																																																																
32	70	53	115	87	190																																																																
26	55	43	95	70	155																																																																
22	45	35	75	55	120																																																																
19	40	30	65	49	110																																																																
16	35	26	55	43	95																																																																
14	30	23	50	38	95																																																																
13	30	21	45	35	75																																																																
<table border="1"> <thead> <tr> <th rowspan="2"></th> <th colspan="2">"D" Dumbbell Length</th> <th rowspan="2">Mounting Type</th> </tr> <tr> <th>cm</th> <th>in</th> </tr> </thead> <tbody> <tr> <td>12</td> <td>31</td> <td>12</td> <td rowspan="4">C or S</td> </tr> <tr> <td>18</td> <td>46</td> <td>18</td> </tr> <tr> <td>24</td> <td>61</td> <td>24</td> </tr> <tr> <td>30</td> <td>76</td> <td>30</td> </tr> <tr> <td>36</td> <td>91</td> <td>36</td> <td rowspan="6">S</td> </tr> <tr> <td>42</td> <td>107</td> <td>42</td> </tr> <tr> <td>48</td> <td>122</td> <td>48</td> </tr> <tr> <td>54</td> <td>137</td> <td>54</td> </tr> <tr> <td>60</td> <td>152</td> <td>60</td> </tr> <tr> <td>66</td> <td>168</td> <td>66</td> </tr> <tr> <td>72</td> <td>188</td> <td>72</td> <td></td> </tr> </tbody> </table>											"D" Dumbbell Length		Mounting Type	cm	in	12	31	12	C or S	18	46	18	24	61	24	30	76	30	36	91	36	S	42	107	42	48	122	48	54	137	54	60	152	60	66	168	66	72	188	72																			
	"D" Dumbbell Length		Mounting Type																																																																		
	cm	in																																																																			
12	31	12	C or S																																																																		
18	46	18																																																																			
24	61	24																																																																			
30	76	30																																																																			
36	91	36	S																																																																		
42	107	42																																																																			
48	122	48																																																																			
54	137	54																																																																			
60	152	60																																																																			
66	168	66																																																																			
72	188	72																																																																			
<p>Note: Capacity @ 65 psi</p>																																																																					

Swivel Mount

Max Torque: 1356 Nm (1000 ftlb)

Max Balancing Capacity @ 65 psi: 49 kg (110 lb), 88 kg (195 lb), or 157 kg (345 lb)

HAS Heavy Duty Articulating Arm offers interfaces for overhead bridge, floor pedestal or special mounting.

- Ergonomics Improve Operator Interface
- Zero-gravity tool balancing and elimination of torque reaction exposure reduces operator fatigue
- Increases Fastening Accuracy and Consistency
- Eliminates operator effects on results by absorbing the torque reaction impulse
- Features Ensure Reliable Operation
- All critical fasteners are either safety wired or pinned
- Safety check valves maintain load position if a sudden loss of supply air pressure occurs

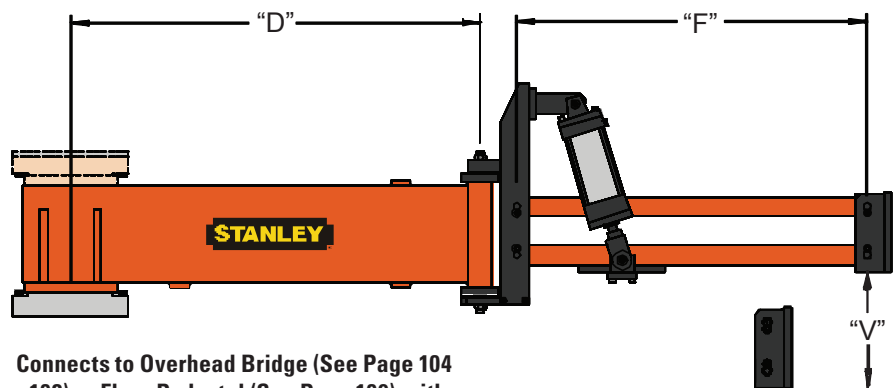

Connects to Overhead Bridge (See Page 104 - 108) or Floor Pedestal (See Page 109) with Clevis Mount.

Model Number Build					
HAS		##	A, B, or C		##

"F" Forearm Length		"V" Vertical Travel		
cm	in	cm	in	
61	24	31	12	24
76	30	38	15	30
91	36	46	18	36
107	42	53	21	42
122	48	61	24	48
137	54	69	27	54
152	60	76	30	60

Cylinder Size Max Balancing Capacity					
A (2")		B (2.5")		C (3")	
kg	lb	kg	lb	kg	lb
49	110	88	195	157	345
39	85	73	160	129	285
30	65	59	130	106	235
24	50	49	105	90	195
19	40	41	90	76	170
15	35	35	75	67	145
13	30	30	65	59	130

Note: Capacity @ 65 psi

	"D" Dumbbell Length	
	cm	in
12	31	12
18	46	18
24	61	24
30	76	30
36	91	36
42	107	42
48	122	48
54	137	54
60	152	60
66	168	66
72	188	72
84	213	84
96	244	96

Engineered Systems - Overhead Bridges

LBC Light Duty Overhead Bridge - For Clevis Arm Mount

Max Length: 244 cm (96 in)

LBC Light Duty Overhead Bridges interface STANLEY Articulating Arms to all common overhead rails. Bridge mast includes leveling jacks.

- All critical fasteners are either safety wired or pinned to ensure reliable operation
- Rugged and simple construction

NOTE: "Duty" level of Overhead Bridge must match "Duty" level of Articulating Arm. (ie: Medium Duty Bridge for Medium Duty Arm.)

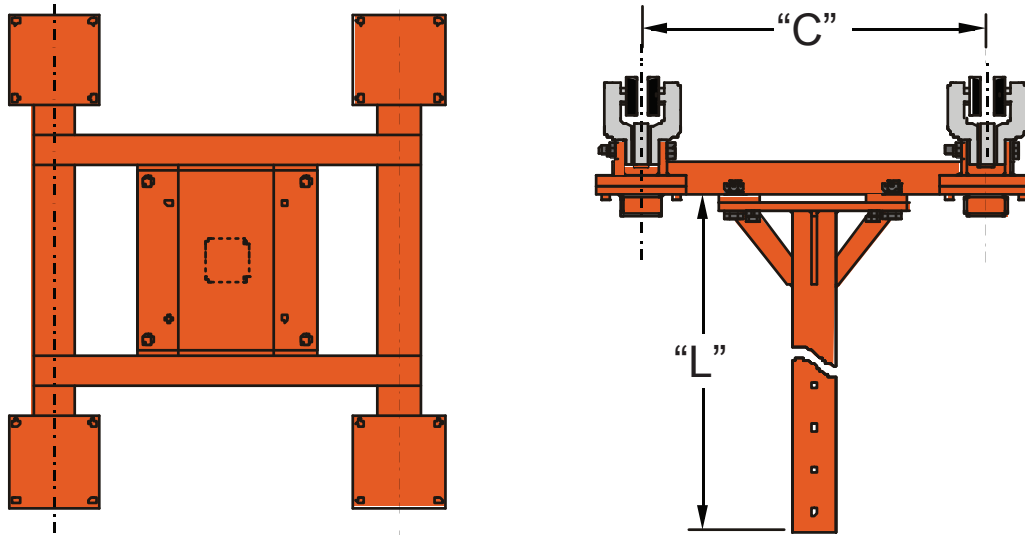

Model Number Build																																																																										
LBC	##	X	##																																																																							
<table border="1"> <thead> <tr> <th colspan="2">"C" Runway Rail Center Distance</th> </tr> <tr> <th>cm</th> <th>in</th> </tr> </thead> <tbody> <tr><td>30.5</td><td>12</td></tr> <tr><td>45.7</td><td>18</td></tr> <tr><td>61</td><td>24</td></tr> <tr><td>76.2</td><td>30</td></tr> <tr><td>91.4</td><td>36</td></tr> <tr><td>121.9</td><td>48</td></tr> <tr><td>152.4</td><td>60</td></tr> </tbody> </table>		"C" Runway Rail Center Distance		cm	in	30.5	12	45.7	18	61	24	76.2	30	91.4	36	121.9	48	152.4	60	<table border="1"> <thead> <tr> <th colspan="2">Trolley Suspension</th> </tr> </thead> <tbody> <tr><td>4" I-Beam Trolley</td><td>A</td></tr> <tr><td>6" I-Beam Trolley</td><td>B</td></tr> <tr><td>3.25" or 3.33" Flat Track Trolley</td><td>C</td></tr> <tr><td>Unified ETA-4 Trolley</td><td>D</td></tr> <tr><td>Unified ETA-8 Trolley</td><td>E</td></tr> <tr><td>Demag KBKI Trolley</td><td>F</td></tr> <tr><td>Demag KBKII-L Trolley</td><td>G</td></tr> <tr><td>IR/Zimmerman Trolley ZRA1</td><td>H</td></tr> <tr><td>IR/Zimmerman Trolley ZRA2</td><td>I</td></tr> </tbody> </table>	Trolley Suspension		4" I-Beam Trolley	A	6" I-Beam Trolley	B	3.25" or 3.33" Flat Track Trolley	C	Unified ETA-4 Trolley	D	Unified ETA-8 Trolley	E	Demag KBKI Trolley	F	Demag KBKII-L Trolley	G	IR/Zimmerman Trolley ZRA1	H	IR/Zimmerman Trolley ZRA2	I	<table border="1"> <thead> <tr> <th colspan="3">"L" Down Mast Length</th> </tr> <tr> <th></th> <th>cm</th> <th>in</th> </tr> </thead> <tbody> <tr><td>24</td><td>61</td><td>24</td></tr> <tr><td>30</td><td>76.2</td><td>30</td></tr> <tr><td>36</td><td>91.4</td><td>36</td></tr> <tr><td>42</td><td>106.7</td><td>42</td></tr> <tr><td>48</td><td>121.9</td><td>48</td></tr> <tr><td>60</td><td>152.4</td><td>60</td></tr> <tr><td>72</td><td>182.9</td><td>72</td></tr> <tr><td>84</td><td>213.4</td><td>84</td></tr> <tr><td>96</td><td>243.8</td><td>96</td></tr> </tbody> </table>	"L" Down Mast Length				cm	in	24	61	24	30	76.2	30	36	91.4	36	42	106.7	42	48	121.9	48	60	152.4	60	72	182.9	72	84	213.4	84	96	243.8	96
"C" Runway Rail Center Distance																																																																										
cm	in																																																																									
30.5	12																																																																									
45.7	18																																																																									
61	24																																																																									
76.2	30																																																																									
91.4	36																																																																									
121.9	48																																																																									
152.4	60																																																																									
Trolley Suspension																																																																										
4" I-Beam Trolley	A																																																																									
6" I-Beam Trolley	B																																																																									
3.25" or 3.33" Flat Track Trolley	C																																																																									
Unified ETA-4 Trolley	D																																																																									
Unified ETA-8 Trolley	E																																																																									
Demag KBKI Trolley	F																																																																									
Demag KBKII-L Trolley	G																																																																									
IR/Zimmerman Trolley ZRA1	H																																																																									
IR/Zimmerman Trolley ZRA2	I																																																																									
"L" Down Mast Length																																																																										
	cm	in																																																																								
24	61	24																																																																								
30	76.2	30																																																																								
36	91.4	36																																																																								
42	106.7	42																																																																								
48	121.9	48																																																																								
60	152.4	60																																																																								
72	182.9	72																																																																								
84	213.4	84																																																																								
96	243.8	96																																																																								

Other trolleys including anti-kick up available

MB Medium Duty Overhead Bridge - For Swivel or Clevis Arm Mount

Max Length: 244 cm (96 in)

MB Medium Duty Overhead Bridges interface STANLEY Articulating Arms to all common overhead rails. Bridge mast includes leveling jacks.

- All critical fasteners are either safety wired or pinned to ensure reliable operation
- Rugged and simple construction

NOTE: "Duty" level of Overhead Bridge must match "Duty" level of Articulating Arm.
(ie: Medium Duty Bridge for Medium Duty Arm.)

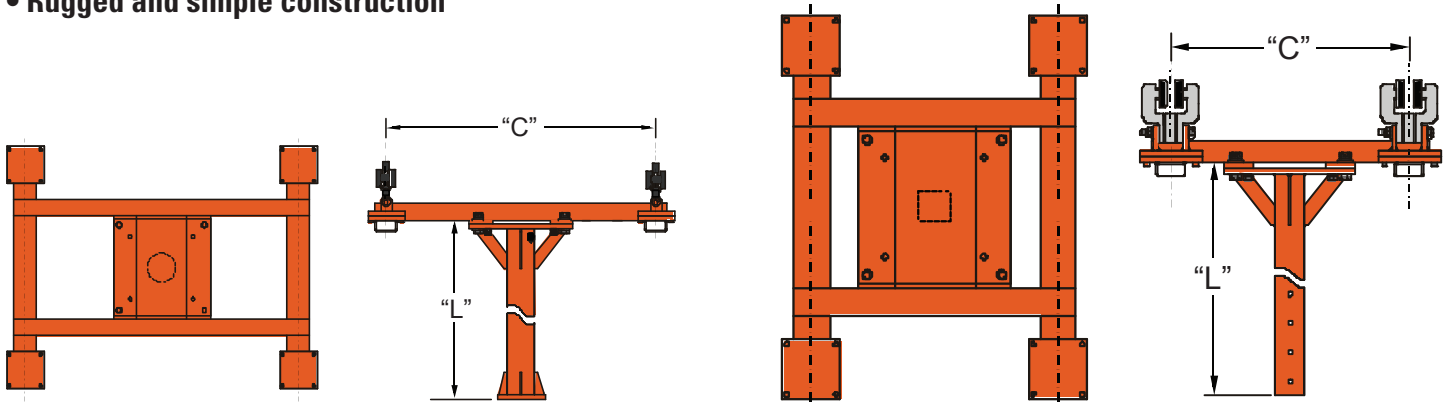

MBC Medium Duty Overhead Bridge with Clevis Mount

MBS Medium Duty Overhead Bridge with Swivel Mount

Model Number Build						
MB	C or S	##	X			##
Mounting Type	Clevis	C				
	Swivel	S				
"C" Runway Rail Center Distance			Trolley Suspension		"L" Down Mast Length	
cm	in	##	4" I-Beam Trolley	A	24	61
30.5	12	12	6" I-Beam Trolley	B	30	76.2
45.7	18	18	3.25" or 3.33" Flat Track Trolley	C	36	91.4
61	24	24	Unified ETA-4 Trolley	D	42	106.7
76.2	30	30	Unified ETA-8 Trolley	E	48	121.9
91.4	36	36	Demag KBKI Trolley	F	60	152.4
121.9	48	48	Demag KBKII-L Trolley	G	72	182.9
152.4	60	60	IR/Zimmerman Trolley ZRA1	H	84	213.4
			IR/Zimmerman Trolley ZRA2	I	96	243.8

Other trolleys including anti-kick up available

Engineered Systems - Overhead Bridges

HBS Heavy Duty Overhead Bridge - For Swivel Arm Mount

Max Length: 244 cm (96 in)

HBS Heavy Duty Overhead Bridges interface STANLEY Articulating Arms to all common overhead rails. Bridge mast includes leveling jacks.

- All critical fasteners are either safety wired or pinned to ensure reliable operation
- Rugged and simple construction

NOTE: "Duty" level of Overhead Bridge must match "Duty" level of Articulating Arm. (ie: Medium Duty Bridge for Medium Duty Arm.)

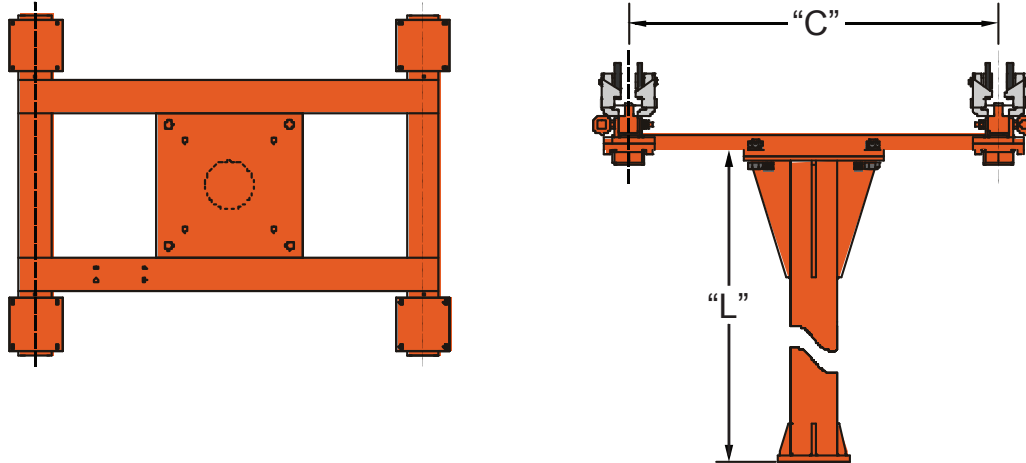

Model Number Build						
HBS	##	X		##		
"C" Runway Rail Center Distance		Trolley Suspension			"L" Down Mast Length	
<i>cm</i>	<i>in</i>	<i>cm</i>	<i>in</i>	<i>cm</i>	<i>in</i>	
45.7	18	18	4" I-Beam Trolley	12	30.5	
61	24	24	6" I-Beam Trolley	18	45.7	
76.2	30	30	3.25" or 3.33" Flat Track Trolley	24	61	
91.4	36	36	Unified ETA-8 Trolley	30	76.2	
121.9	48	42	Demag KBKII-L Trolley	36	91.4	
152.4	60	60	IR/Zimmerman Trolley ZRA1	42	106.7	
			IR/Zimmerman Trolley ZRA2	48	121.9	
				60	152.4	
				72	182.9	
				84	213.4	
				96	243.8	

Other trolleys including anti-kick up available

Pedestals for Clevis or Swivel Arm Mount

Max Length: 244 cm (96 in)

HP/MP/LP Pedestals offer floor mounting for STANLEY Articulating Arms.

- Includes leveling jacks
- All critical fasteners are either safety wired or pinned to ensure reliable operation
- Rugged and simple construction

NOTE: "Duty" level of Pedestal must match "Duty" level of Articulating Arm.
(ie: Medium Duty Pedestal for Medium Duty Arm.)

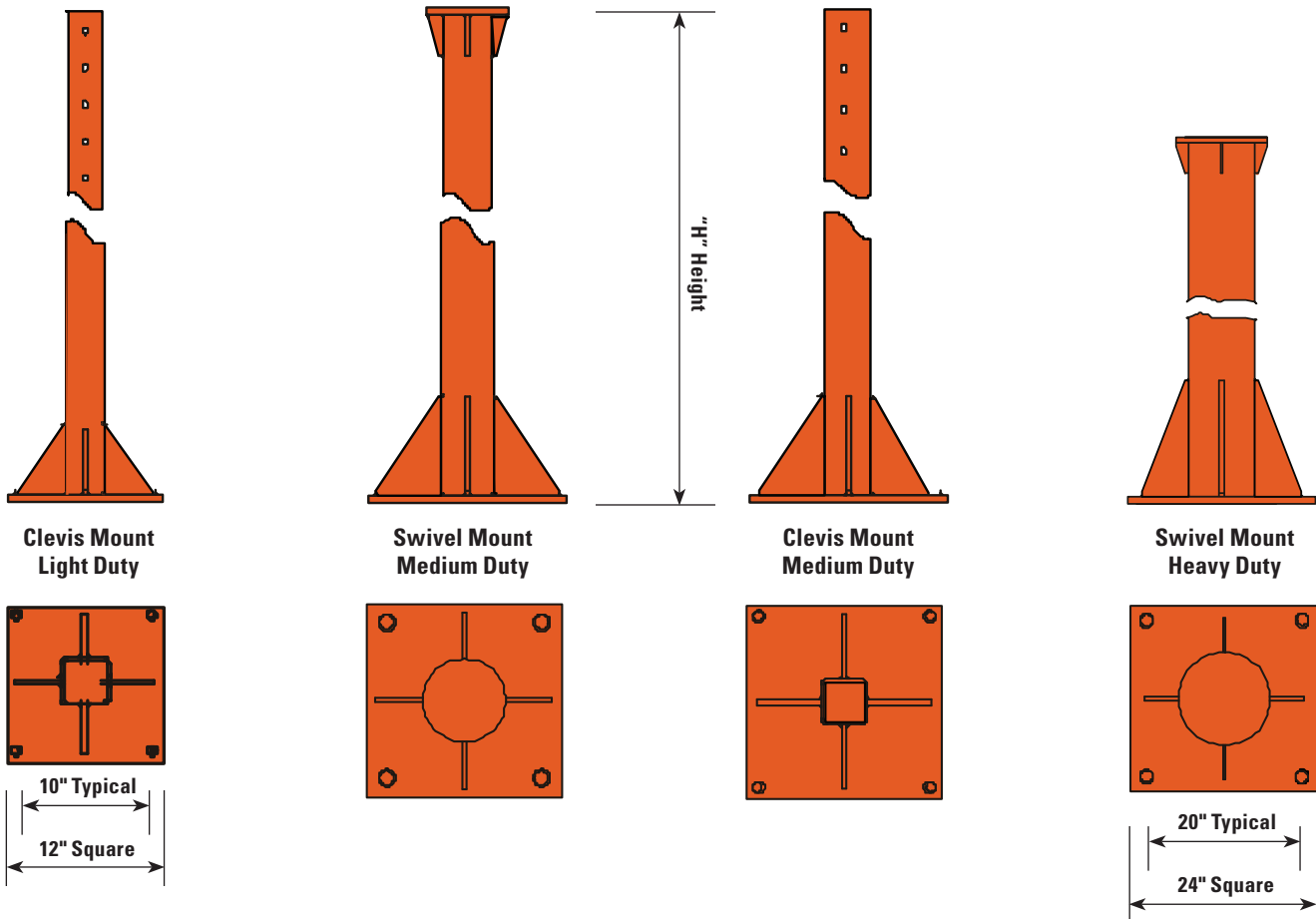

Model Number Build																																				
XX	C or S	##																																		
<table border="1"> <thead> <tr> <th colspan="2">Duty Level</th> </tr> </thead> <tbody> <tr> <td>LP</td> <td>Light</td> </tr> <tr> <td>MP</td> <td>Medium</td> </tr> <tr> <td>HP</td> <td>Heavy</td> </tr> </tbody> </table>	Duty Level		LP	Light	MP	Medium	HP	Heavy	<table border="1"> <thead> <tr> <th colspan="2">Mounting Type</th> </tr> </thead> <tbody> <tr> <td>Clevis*</td> <td>C</td> </tr> <tr> <td>Swivel**</td> <td>S</td> </tr> </tbody> </table>	Mounting Type		Clevis*	C	Swivel**	S	<table border="1"> <thead> <tr> <th rowspan="2"></th> <th colspan="2">"H" Mast Height</th> </tr> <tr> <th>cm</th> <th>in</th> </tr> </thead> <tbody> <tr> <td>60</td> <td>152.4</td> <td>60</td> </tr> <tr> <td>72</td> <td>182.9</td> <td>72</td> </tr> <tr> <td>84</td> <td>213.4</td> <td>84</td> </tr> <tr> <td>96</td> <td>243.8</td> <td>96</td> </tr> <tr> <td>108</td> <td>247.3</td> <td>108</td> </tr> </tbody> </table>		"H" Mast Height		cm	in	60	152.4	60	72	182.9	72	84	213.4	84	96	243.8	96	108	247.3	108
	Duty Level																																			
	LP	Light																																		
MP	Medium																																			
HP	Heavy																																			
Mounting Type																																				
Clevis*	C																																			
Swivel**	S																																			
	"H" Mast Height																																			
	cm	in																																		
60	152.4	60																																		
72	182.9	72																																		
84	213.4	84																																		
96	243.8	96																																		
108	247.3	108																																		

*Not available on HP (Heavy Duty) models

**Not available on LP (Light Duty) models

AA Series Tools



The new AA series pneumatic nutrunners from STANLEY offers an industry leading range of clutch shut off tools providing tool choices that improve assembly quality, productivity and ergonomics to enhance assembly processes.

The adjustable clutch on the AA series nutrunners provides a high level of torque control for most general use applications. The tool's output torque is controlled by adjusting a mechanical spring that provides axial force on steel balls rolling between indented plates. By providing smooth disengagement at a preset torque while minimizing vibration to the operator, these tools are a great choice for fastening applications requiring torque values from 4.5 to 118 Nm.

The same trusted quality outputs as the STANLEY QPM DC tools are used on these AA clutch tools reducing costly complexity and end user spare parts needs. Gearless reverse selection method also reduces parts and complexity for improved Mean Time To Repair (MTTR) and Mean Time Between Failure (MTBF).

AA clutch tools have a free speed air consumption rate of 14.2 liters/second (30 cfm).



AA Series Pneumatic Tools conform to ISO standards 28927-2 and 15744 for noise and vibration. Actual vibration of AA23 and AA33 series tools is < 2.5 m/sec . AA23 series tools' noise was measured at 79 dBA sound pressure levels. AA33 series tools' noise was measured at 85 dBA sound pressure levels. AA33 series tools' noise was measured at 96 dBA sound power level.

AA Angle Tools (4.5 to 118 Nm)

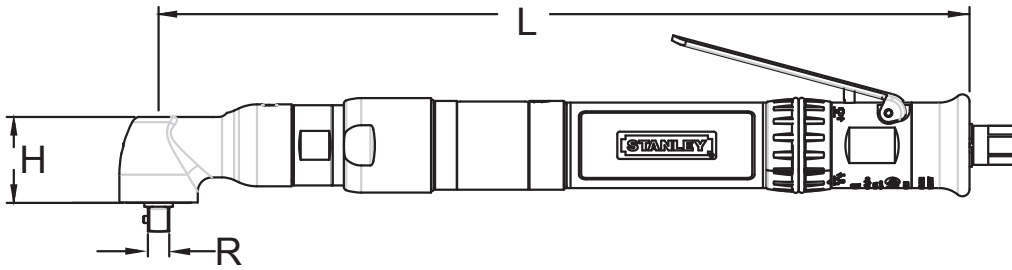

Model	Rated Speed		Torque		"R" Side to Center		"H" Head Height		"L" Length		Weight		Output
	RPM	Nm	lb ft	mm	in	mm	in	mm	in	kg	lb	Standard	
AA23LA14-9	1550	9	6.6	14	0.55	36	1.4	312.6	12.3	1.4	3.1	3/8" SD	
AA23LA13-14	1000	14	10.3	13	0.51	33	1.3	304.6	12.0	1.4	3.1		
AA23LA14-18	840	18	13.3	14	0.55	36	1.4	312.6	12.3	1.4	3.1		
AA33LA14-18	1110	18	13.3	14	0.55	36	1.4	352.2	13.9	1.6	3.6		
AA23LA14-22	665	22	16.2	14	0.55	36	1.4	312.6	12.3	1.6	3.5		
AA33LA14-25	790	25	18.4	14	0.55	36	1.4	352.2	13.9	1.6	3.6		
AA33LA14-28	500	28	20.7	14	0.55	36	1.4	352.2	13.9	1.6	3.6		
AA23LA18S-30	485	30	22.1	18	0.71	39	1.5	315.0	12.4	1.6	3.5		
AA33LA18S-40	500	40	29.5	18	0.71	39	1.5	354.8	14.0	1.7	3.9		
AA33LA18S-45	440	45	33.2	18	0.71	39	1.5	354.8	14.0	1.7	3.9		
AA33LA18S-50	390	50	36.9	18	0.71	39	1.5	354.8	14.0	1.7	3.9		

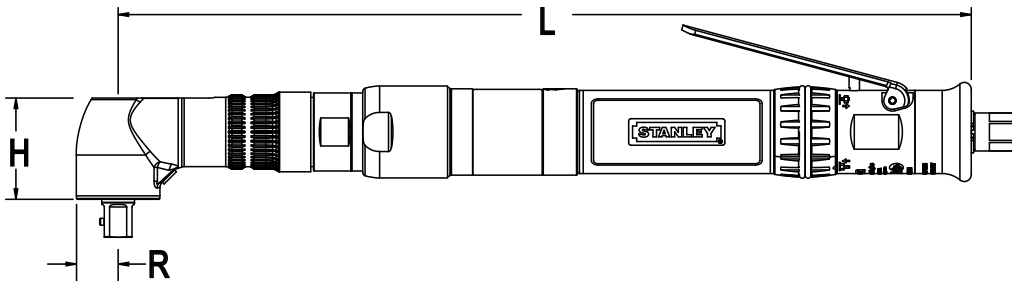

Model	Rated Speed		Torque		"R" Side to Center		"H" Head Height		"L" Length		Weight		Output
	RPM	Nm	lb ft	mm	in	mm	in	mm	in	kg	lb	Standard	
AA33LA19-59	335	59	43.5	19	0.75	46.4	1.8	390.8	15.4	2.1	4.6	1/2" SD	
AA33LA19-70	250	70	51.6	19	0.75	46.4	1.8	390.8	15.4	3.6	7.9		
AA33LA22A-106	180	106	78.2	22	0.87	47.9	1.9	474.8	18.7	2.9	6.5		
AA33LA22A-118	160	118	87	22	0.87	47.9	1.9	458.7	18.1	2.9	6.5		

AA Angle Tool Options

A13 Output	Part No.
3/8" Double-Ended	20D121912
Flush Socket *	20D121914
1/4" Quick Change	20D121916
1/4" SD	20D121919
1/4" Magnetic Internal Hex	20D121920
A14 Output	Part No.
1/4" Internal Hex	20D112110
Flush Socket *	20D112113
Flush Socket Rubber Cover	20S210000
A18S Output	Part No.
3/8" Double-Ended	20D136502
Flush Socket *	20D136503
A19 Output	Part No.
Threaded Flush Socket *	20D100021
A22 Output	Part No.
Flush Socket	20D100309
1/2" Double-Ended	20D100326
With Guided Extension Collar	20D100321
AA23 Handle	Part No.
NPT Air Inlet	20H103700
ISO Air Inlet	20H103701
AA33 Handle	Part No.
NPT Air Inlet	20H103800
ISO Air Inlet	20H103801
Socket Lock Pin	Part No.
Standard	20D227800
Rounded (Ball Detent)	20D227801
A19 / A22 Reaction Components	Part No.
Reaction Bar Assembly	20K100000
Mounting Flange	20K100300
Base Mount Bracket Assembly	20K100500

* Flush socket selection starts on page 158

AA Angle Tool Suspension Bails

Output	Part No.
A13	20K101400
A14	20K101400
A18S	20K101400
A19	20K101400
A22	20K200000

AA Tool Adjustment Screwdriver	20K401900
--------------------------------	-----------

AA - Inline Lever Tools

AA Inline Tool Options

Reaction Bar	Part No.
Reaction Bar, Aluminum	F3698
Reaction Bar, Steel	20K100100
Base Mount Bracket	A8606
Mounting Flange-B	20K101000
AA23 Handle	Part No.
NPT Air Inlet	20H103700
ISO Air Inlet	20H103701
AA33 Handle	Part No.
NPT Air Inlet	20H103800
ISO Air Inlet	20H103801
Socket Lock Pin	Part No.
Standard	20D227800
Rounded (Ball Detent)	20D227801
AA23 Handle	Part No.
NPT Air Inlet	20H103700
ISO Air Inlet	20H103701
AA Tool Adjustment Screwdriver	20K401900

AA Inline Tools (5.5 to 54 Nm)

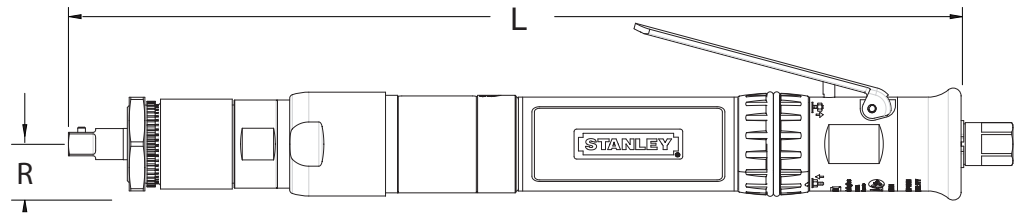

Model	Rated Speed		Torque		"R" Side to Center		"L" Length		Weight		Output	
	RPM	Nm	lb ft	mm	in	mm	in	kg	lb	Standard	Options	
AA23LB-11	1280	11	8.1	22.7	0.89	328.4	12.9	1.5	3.2	3/8" SD	1/4" QC	
AA23LB-15	990	15	11.1	22.7	0.89	322.4	12.7	1.5	3.2	3/8" SD	1/4" QC	
AA23LB-21	680	21	15.5	22.7	0.89	322.4	12.7	1.5	3.2	3/8" SD	N/A	
AA33LB-32	630	32	23.6	22.7	0.89	350.9	13.8	1.6	3.6	3/8" SD		
AA33LB-40	500	40	29.5	22.7	0.89	350.9	13.8	1.6	3.6	3/8" SD		
AA33LB-54	370	54	39.8	22.7	0.89	350.9	13.8	1.6	3.6	3/8" SD		

Hold & Drive Options

A Tang holds the bolt while the nut is tightened

A Bit holds the bolt while the nut is tightened

Typical Tang Options



Female Torx



Female Hex



Rectangular

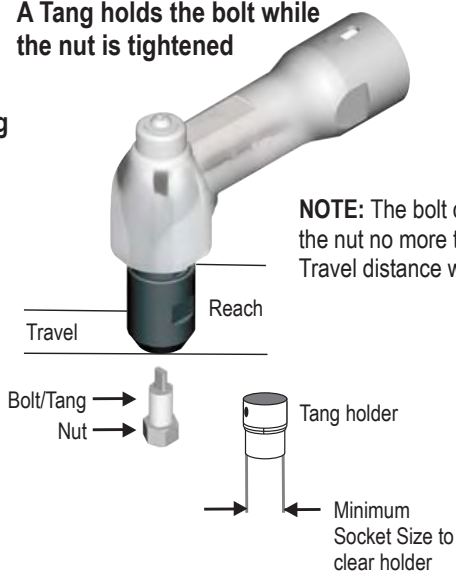

NOTE: The bolt can extend beyond the nut no more than the specified Travel distance when tightened.

Typical Bit Options



Male Hex



Male Torx

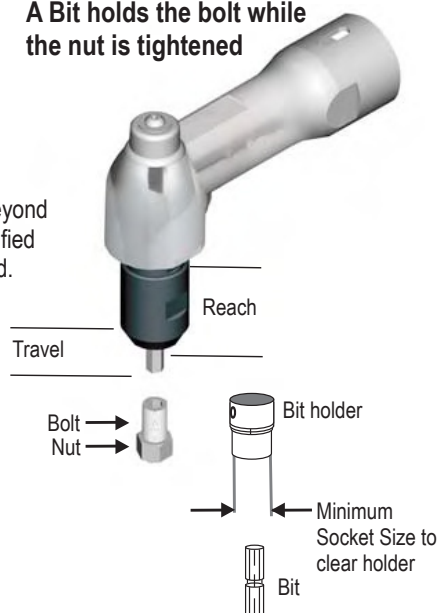

AA Hold & Drive Tools (14 to 110 Nm)

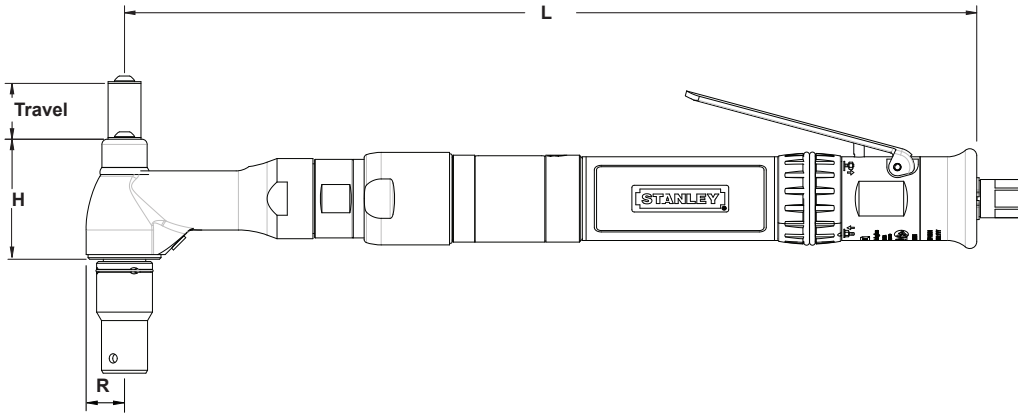

Model	Rated Speed		Torque		"R" Side to Center		"H" Head Height		"L" Length		Weight		Output
	RPM	Nm	lb ft	mm	in	mm	in	mm	in	kg	lb		
AA23LH18V1-28	485	28	20.7	18	0.71	131.9	5.2	341.7	13.5	1.8	4.0	25mm (1")	
AA33LH18V1-46	343	46	33.9	18	0.71	131.9	5.2	387.8	15.3	1.9	4.18		
AA33LH22AV1-99	175	99	73	22	0.87	143.8	5.7	468.3	18.4	3.3	7.26		
AA33LH22AV1-110	141	110	81	22	0.87	143.8	5.7	468.3	18.4	3.3	7.26		
AA23LH18V2-28	485	28	20.7	18	0.71	190.3	7.5	341.7	13.5	1.8	4.0	50mm (2")	
AA33LH18V2-46	343	46	33.9	18	0.71	190.3	7.5	387.8	15.3	1.9	4.18		
AA33LH22AV2-99	175	99	73	22	0.87	199.0	7.8	468.3	18.4	3.3	7.26		
AA33LH22AV2-110	141	110	81	22	0.87	199.0	7.8	468.3	18.4	3.3	7.26		

AA Hold & Drive Options

H18 Output	Part No.
Socket Options (See Page 165 for 20D905700 Socket Options)	20D905700
1" Travel Bit Holder Output	20D124600
2" Travel Bit Holder Output	20D124601
1" Travel Tang Holder Output	20D124602
2" Travel Tang Holder Output	20D124603
H18 Tang Holder	Part No.
6mm x 8mm Rectangle	20D261700
5mm x 7.5mm Rectangle	20D261701
6mm x 10mm Rectangle	20D261702
6mm Hex	20D261703
H18 Bit Holder	Part No.
1/4" Hex	20D254200
5/16" Hex	20D253400
Suspension Bails	Part No.
Wire Bail	A3061
Swivel	20K101400
Standard	B3432
Mounting Flange-B	20K101000
H22 Output	Part No.
Socket Options (See Page 165 for ~N4617 Socket Options)	~N4617
1" Travel Tang Holder Output	20D103211
1" Travel Bit Holder Output	20D103212
2" Travel Tang Holder Output	20D103213
2" Travel Bit Holder Output	20D103214
H22 Tang Holder	Part No.
Tang Holder Options *	~F4287
H22 Bit Holder	Part No.
Bit Holder Options *	~F4288

* Selection starts on page 165

AA23 Handle	Part No.
NPT Air Inlet	20H103700
ISO Air Inlet	20H103701
AA33 Handle	Part No.
NPT Air Inlet	20H103800
ISO Air Inlet	20H103801
Reaction Bar	Part No.
Reaction Bar Assembly	20K100000
Mounting Flange Assembly	20K100300
Base Mount Bracket Assembly	20K100500
Swivel Suspension Bails	Part No.
Non-Splined	20K101400
Splined	20K200000
AA Tool Adjustment Screwdriver	Part No.
	20K401900

AA - Crowfoot Lever Tools

AA Crowfoot Tools (6.5 to 70 Nm)

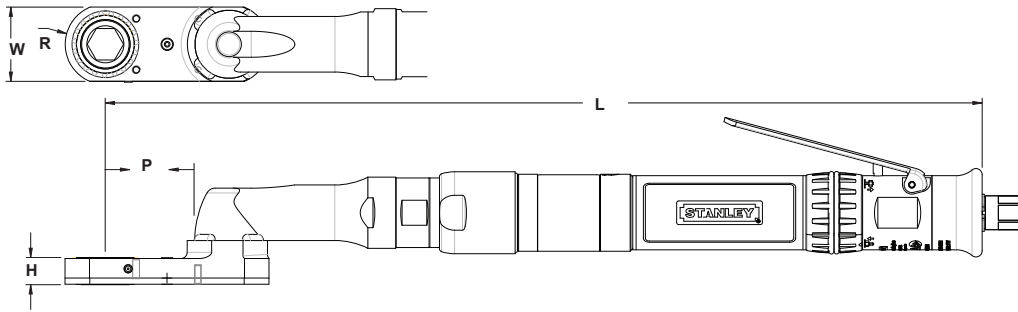

Model	Rated Speed		Torque		"R" Nose Radius		"T" Thickness		"W" Width		"P" Length		"L" Length		Weight		Maximum Hex Size	
	RPM		Nm	lb ft	mm	in	mm	in	mm	in	mm	in	mm	in	kg	lb	mm	in
AA23LC106-13	745		13	9.6	12.7	0.50	16.2	0.64	25.4	1.00	64.6	2.50	370	14.6	1.6	3.5	13	0.50
AA23LC385-17	540		17	12.5	11.9	0.47	15.9	0.63	31.8	1.25	69.2	2.70	374	14.7	1.6	3.5	13	0.50
AA23LC308-19	505		19	14	13.5	0.53	20.6	0.81	31.8	1.25	70.2	2.80	376	14.8	2.7	5.95	13	0.50
AA23LC297-21	450		21	15.5	16.0	0.63	20.6	0.81	31.8	1.25	71.0	2.80	376	14.8	2.85	6.28	14	0.56
AA23LC66-21	450		21	15.5	16.0	0.63	21.3	0.84	31.8	1.25	28.5	1.10	333	13.1	2.81	6.2	14	0.56
AA23LC362-25	370		25	18.4	12.7	0.50	15.9	0.63	25.9	1.02	65.8	2.60	370	14.6	2.57	5.67	13	0.50
AA33LC516-30	420		30	22.1	13.0	0.51	16.0	0.63	32.0	1.25	70.0	2.76	478	18.8	2.68	5.91	13	0.50
AA23LC521-30	285		30	22.1	13.0	0.51	16.0	0.63	32.0	1.25	45.0	1.76	376	14.8	2.57	5.67	13	0.50
AA33LC29-31	390		31	22.9	21.0	0.81	14.0	0.55	38.1	1.50	43.0	1.70	348	13.7	2.4	5.3	19	0.75
AA33LC308-31	420		31	22.9	13.5	0.53	20.6	0.81	31.8	1.25	70.2	2.80	415	16.3	2.98	6.58	13	0.50
AA33LC297-35	370		35	25.8	16.0	0.63	20.6	0.81	31.8	1.25	71.0	2.80	376	14.8	3.13	6.91	14	0.56
AA33LC66-40	325		40	29.5	16.0	0.63	21.3	0.84	31.8	1.25	28.5	1.10	354	13.9	3.1	6.83	14	0.56
AA33LC97-47	235		47	34.7	21.6	0.81	21.3	0.84	38.0	1.48	107	4.20	518	20.4	3.99	8.8	19	0.75
AA33LC506-50	235		50	36.9	33.0	1.30	17.0	0.68	66.0	2.60	52.0	2.03	407	16.0	3.59	7.92	38	1.50
AA33LC298-53	250		53	39.1	13.2	0.52	20.9	0.82	38.1	1.50	96.5	3.80	452	17.8	3.91	8.62	13	0.50
AA33LC162-55	225		55	40.6	13.2	0.52	20.9	0.82	38.1	1.50	97.0	3.82	596	23.5	3.91	8.62	13	0.50
AA33LC499-58	210		58	42.8	13.2	0.52	16.5	0.65	38.0	1.48	155.0	6.10	510	20.1	3.99	8.8	13	0.50
AA33LC31-70	170		70	51.6	20.6	0.81	27.9	1.10	38.1	1.50	38.9	1.50	514	20.2	3.8	8.4	19	0.75

AA Crowfoot Tool Options

AA23 Handle	Part No.
NPT Air Inlet	20H103700
ISO Air Inlet	20H103701
AA33 Handle	Part No.
NPT Air Inlet	20H103800
ISO Air Inlet	20H103801
Reaction Bar	Part No.
Reaction Bar Assembly	20K100000
Mounting Flange Assembly	20K100300
Base Mount Bracket Assembly	20K100500
Swivel Suspension Bails	Part No.
Non-Splined Output	20K101400
Splined Output	20K200000
AA Tool Adjustment Screwdriver	20K401900

See Page 168 for Crowfoot Vinyl Cover Options
See Page 143 for Crowfoot Socket Selection

AA Tool Motor Service Kits

Descriptions	Part Number
AA23 Motor Housing Service Kit	20M103400
AA33 Motor Housing Service Kit	20M103401
AA23 Motor Service Parts	20M103450
AA23 Motor Service Parts	20M103451
AA2/ 3 Handle Rebuild Kit	20H104800
AA2/ 3 Clutch Service Kit	20G110400

Each of these tools is required to repair the AA motor. It is recommended to buy the complete kit once then any one of the components as needed when they wear out.

AA Motor Repair Tools

Descriptions	Part Number
AA Motor Assembly / Disassembly Tool Kit (contains 1-each of the parts below)	20V102400
Motor Assembly Block	20V202001
Rear Bearing Press Tool	20V102300
Motor Bearing Removal Tool	20V202600
Motor Front Bearing Removal Tube	20V203200
Rear Bearing Removal Press Tool	20V201900
Motor Rear Bearing Removal Tube	20V203300

20V102400 AA Motor Repair Tool Kit Parts

Descriptions	Part Number
Throttle Seat Install Tool	20V102000
Throttle Lever Install Tool	20V102100
Rear Bearing Press Tool, AA2/3	20V102300
A13-19 Assembly Tool	20V200700
Clutch Cam Assembly Install Tool	20V201400
Rear Brg Removal Press Tool, AA2/3	20V201900
Motor Assembly Block, AA2/3	20V202001
Motor Bearing Removal Tool, AA2/3	20V202600
Throttle Seat Install Plug AA2/3	20V202800
Motor Front Bearing Removal Tube	20V203200
Motor Rear Bearing Removal Tube	20V203300
QPM #3 Gear Case To Angle Head Socket	20V204000

See AA Tool Manual for Use.



Enable Error Proofing of Threaded Fastening With all Types of Pneumatic Tools



PSI-Qualifiers improve assembly quality by enabling error proofing to prevent missed fasteners or incomplete fastening cycles. Incomplete fastening cycles that are identified and alarmed include:

- Rehits of a pre-tightened fastener
- Cross-thread of fasteners into mating threads
- Slip-off (or cam out) of the socket or screwdriver bit from the fastener head before fastening to final torque.
- Short cycle (premature cycle abort) by the operator prior to fastening to final torque.



PSI-Q Monitors Shutoff Pneumatic Tools

The PSI-Q monitors each fastening cycle to detect incomplete cycles and report complete cycles.

PSI-Qc Adds Shutoff to Non-shutoff Pneumatic Tools

The PSI-Qc monitors each fastening cycle and uses a solenoid valve to shutoff the tool at the end of the cycle. Incomplete cycles are detected and alarmed.

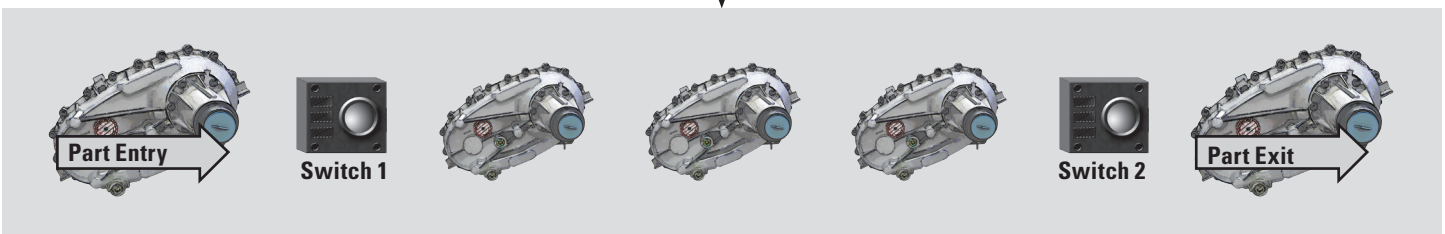

Error Proofing with Pneumatic Tool and PSI-Q and Qc

1. Incoming product for assembly resets the fastener count to zero from Switch 1.

2. An operator installs the fasteners with a pneumatic assembly tool. The PSI-Qualifier determines complete versus incomplete assembly cycles. The qualifier displays a green light for each complete assembly cycle. Red lights are illuminated for incomplete cycles from double hits, cross threads, strip outs or short cycles.

3. The PSI-Qualifier increments the fastener count for each fastener installed with a complete cycle. When all of the required fasteners are assembled with completed cycles, the green batch OK light illuminates. If any fasteners have incomplete assembly cycles, the red NOK light illuminates. A 24V signal from the PSI-Qualifier can be used to prevent products from moving out of station (Switch 2) before all fasteners have complete assembly cycles.

PSI-Q(c) Benefits/Features

- Simple menu driven programming; no laptop needed.
- Learn mode records normal cycle and rehit joint signatures
- Results displayed includes target torque, parameter set, bolt count, and OK/NOK
- Programming options include bolt count, target torque, and cycle timer.
- Counts as many as 99 fastening cycles with OK / NOK evaluation for error proofing.
- Count status lights indicate cycle, or batch, "OK" and "NOK". Batch "OK" resets the count and indicator lights.
- Discrete I/O for tie-in to local station controller, light stack or PLC.

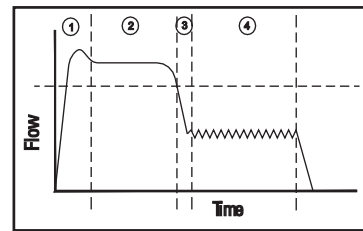
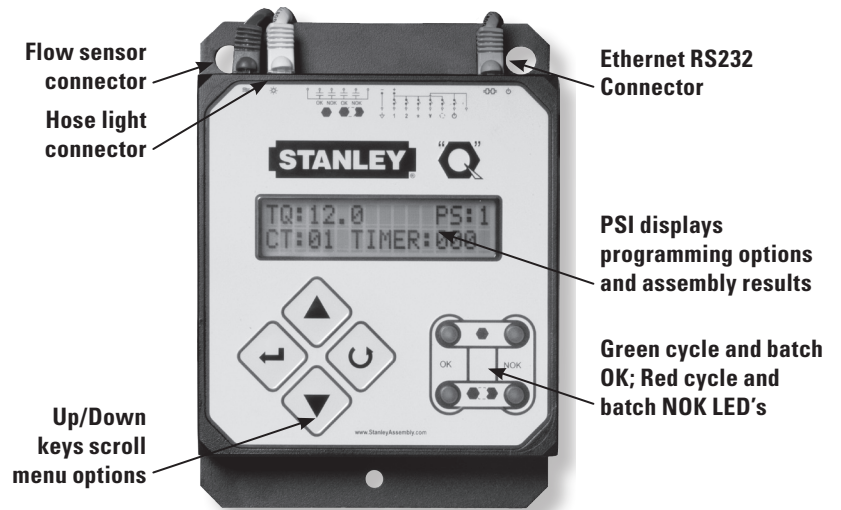

The PSI-Q(c) develops a rundown signature from a series of air flow mass measurements to detect OK vs. NOK fastening cycles.

Controller Descriptions	Part Number
Controller for Shutoff Tools with ≤ 26 Standard Cubic Feet per Minute (SCFM; ft ³ /min) or 12.3 litres per second (l/s)	PSI-Q
Controller for Shutoff Tools with 26 - 65 Standard Cubic Feet per Minute (SCFM; ft ³ /min) or 12.3 - 30.7 litres per second (l/s)	PSI-Q/H
Controller for Non-Shutoff Tools with ≤ 26 Standard Cubic Feet per Minute (SCFM; ft ³ /min) or 12.3 litres per second (l/s)	PSI-Qc
Controller for Non-Shutoff Tools with 26 - 65 Standard Cubic Feet per Minute (SCFM; ft ³ /min) or 12.3 - 30.7 litres per second (l/s)	PSI-Qc/H

The PSI-Q(c) cannot be used to qualify air tools with governors.

Contact a STANLEY office to determine if a particular pneumatic tool can be qualified.

PSI-Q Controller Specifications	
Power Source	100-240 VAC 50-60 Hz
Power Consumption	< 1 amp @ 115 VAC
Operating Conditions Temperature Humidity	0 to +50 °C (32 to 122 °F) 0 to 95 % non-condensing
Weight	1 kg. (2 lbs.) Approximately
Dimensions	15cm (6") wide x 21cm (8.25") high x 4cm (1.5") deep
Inputs/Outputs	Opto-isolated and relay dry contacts; up to 24 VDC/ 5 amps with screw lug terminals
Error Proofing	OK for acceptable cycles vs NOK REHIT/CROSS THREAD, STRIP/SLIP OFF, CYCLE ABORT & BATCH COUNT status
Optional Serial Port	RS 232 port; standard DB connector (OK-NOK, Serial PFCS)
User Interface	Two Line 11mm (0.44") LCD backlit, (16) Characters per line Five-button keypad (Up, Down, Menu, Reset/Reverse & Admin)

Power Supply Options	
24X500092	USA - (default)
24X500143	JAPAN
24X500145	UK
24X500146	EUROPE
24X500144	AUSTRALIA
24C504800	12 VDC Battery Cable

PSI-Q (-Q/H) Options

Option	Part Number	Descriptions
Software	/PQX	Shutoff Tool - (default)
	/PQC	Oetiker Hose Clamp (PSI-Q only)
	/PQP	Air Hammer Pin Press (PSI-Q only)

PSI-Qc (-Qc/H) Options

Option	Part Number	Descriptions
Software	/PQH	Stall Tool High Flow (PSI-Qc/H only)
	/PQT	Stall Tool - (default)
	/PQD	Direct Drive (PSI-Qc only)



The PSI-C/XH is used to control the AT84DB-1300 and the AT86DB-2200 tools. It has one inch input and tool supply lines to provide the proper air flow for these large tools. The external pressure regulator is controlled by the internal regulator with downstream feedback.

PSI-C Transducerized Pulse Tool Process Controller

The PSI-C Transducerized Pulse Tool Process Controller uses closed-loop transducer control of the PSI pulse and impact tools. Functions include tightening control, network connection, and POKE YOKE bolt counting. Simple MENU programming reduces set-up time to less than a minute, no laptop required. It uses an unique pressure control method that adjusts the tool pressure for more repeatable results as compared with line pressure control.

- Transducer Torque Control Improves Precision With Traceability
 - Transducer control gives higher accuracy
 - Data Transfer Unit for traceability
 - Data for every fastening cycle is date and time-stamped then stored for output through serial or Ethernet communication
- Enhances Error-Proofing
 - Red or Green lights signal to the operator the status for each fastener and the total assembly sequence
 - As many as eight parameter sets simplify tool changes for different joints
 - Torque and Pulse Limits detect tightening errors
- Easy Integration with Plant Equipment
 - Discrete I/O for tie-in to local station controller, light stack or PLC
 - Ethernet and RS-232 serial options for networking

Torque Scatter

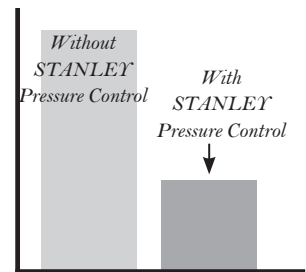

Pressure control method adjusts the line pressure for more repeatable results.

PSI Menus Simplify Assembly Setup

- Programming options include torque target and limits, pulse count limits, calibration per parameter set and bolt count
- Results display includes target torque, parameter set, bolt count, and OK/NOK
- Correlation calibrates PSI to an external reference transducer used during setup only
- Feedback values show the difference between normal cycle and rehit joint signatures for error proofing

Error Proofing with Transducerized Pulse Tools

The PSI-C compares actual torque results to quality limits, counts fastened bolts and detects cross-threads, re-hits and slip-offs. Parts exit the workstation only after all bolts are fastened correctly. Bolts that do not meet torque specifications are identified for rework.

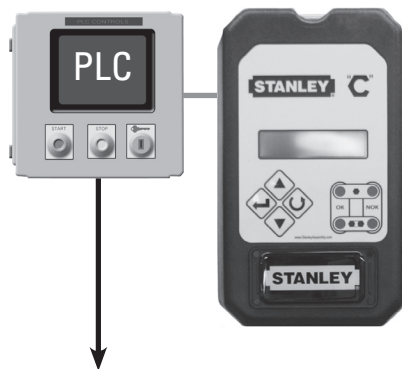

The PSI-C monitors each fastening cycle and shuts off the tool when the target torque is sensed by the tool's transducer. Incomplete cycles or torque values out of specified limits are detected and alarmed.

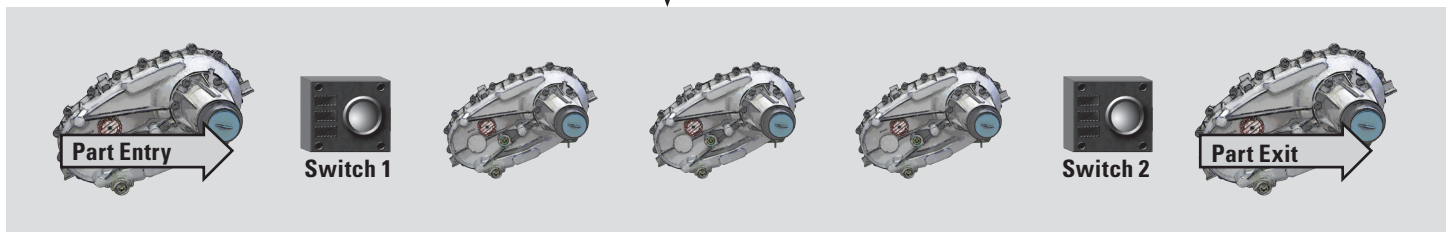

Bolt Counting Enables Error Proofing with Transducerized Pulse Tools

1. Incoming product for assembly resets the fastener count to zero from Switch 1.

2. An operator installs the fasteners with a transducerized pulse assembly tool. The PSI-C controller determines complete assembly cycles to specified torque limits and displays a green light for each complete assembly cycle. Red lights are illuminated for incorrect torque values or incomplete cycles from double hits, cross threads, strip outs or short cycles.

3. The PSI-C controller increments the fastener count for each fastener installed with a complete cycle to specification. When all of the required fasteners are assembled with completed cycles, the green Batch OK light illuminates. If any fasteners have incomplete assembly cycles, the red NOK light illuminates. A 24V signal from the PSI-C can be used to prevent products from moving out of station (Switch 2) before all fasteners have complete assembly cycles.

Power Supply Options

24X500092	USA - (default)
24X500143	JAPAN
24X500145	UK
24X500146	EUROPE
24X500144	AUSTRALIA
24C504800	12 VDC Battery Cable

Model Number	1/4" Tool Inlet	3/8" Tool Inlet	3/4" SD Tool	1" SD Tool	Smart Tool
PSI-C	✓	✓			
PSI-C2	✓	✓			✓
PSI-C/H			✓		
PSI-C2/H			✓		✓
PSI-C/XH				✓	
PSI-C2/XH				✓	✓

PSI-C Controller Specifications

Operator Interface: <ul style="list-style-type: none"> Dual Line 0.5" LCD backlit (16) character Four-button keypad (Enter, Up, Down & Reset/Reverse) LEDs indicate Cycle and Batch Status: Green=OK / Red=NOK REVERSE button; hold down for reverse; momentary for batch reset 	Inputs: Disable, Batch Clear, with screw lug terminal connection, Opto isolated & dry contact relays
	Outputs: Cycle OK / NOK & Batch OK / NOK Dry contact relays; accepts up to 48V DC and 10 amps
	Standard Data Output: Serial RS 232; ASCII
Operating Conditions: Humidity: 0 - 95% non-condensing Temperature: 0 to +50 degrees Celsius	Dimensions: 20w x 30.5h x 15d cm (8w x 12h x 6d in) 5 kg (10.5 lb)
Power Source: 100-240V AC 60/50 Hz	Air Supply: 80 scfm @ 6 bar pressure (87 psi)

PSI-C (-C2, -C/H, -C2/H, -C/XH, -C2/XH) Options

Option	Part Number	Descriptions
Printer Assembly	24X500173	Printer Assy- Internal Label
	24K500147	Case of 20 Rolls (200 labels per roll)
Network	24B100107/PNS	Serial PFCS
	24B100107/PNX	Basic Ethernet
	24B100107/PNE	Ethernet PFCS
	24B100107/PNO	Ethernet Open Protocol
	24B500431/PMX	HDS Network Card - Web Server - Stores ~1.67 million fastening cycles
Barcode	24K500507	Bar Code Adapter Kit (does not include scanner)
	24K500464	Wireless Bar Code Scanner
	24K500500	Wired Bar Code Scanner



The PSI Family of Intelligent Air Tools

STANLEY Assembly Technologies is a leading provider of threaded fastening solutions for the global industrial assembly market. The innovative and reliable “PSI Family” includes error-proofing solutions to monitor or control, pulse, impact and gear driven tools ranging from <1 to 2,200 Nm.

STANLEY PSI - Advancing 50 years of proven fastening methods with technology for the 21st century.

The STANLEY Intelligent Air Tool solutions include:

- Economical error proofing solutions for all types of pneumatic tools. Intelligent systems ensure that the process is completed correctly every time.
- Pulse, impact and direct drive tools with options for fastening cycle control. Control methods include clutch shutoff, transducer control and electronic cycle monitoring with or without solenoid shutoff
- Torque capacities from <1 to 2,200 Nm and higher are available in geometries that can fit the operator and the job.

STANLEY offers simple, robust and highly economical transducerized pulse and impact tools. Pulse and impact tools reduce the torque reaction allowing hand fastening without reaction devices for torque levels as high as 700 Nm on pistol tools and 2,200 Nm on straight tools.

Enhance Quality and Productivity

- Dual chamber motor and double blade pulsing mechanism speed tightening
- Pistol or straight models fit different tightening applications

Ergonomic Design Reduces Operator Fatigue

- Virtually no torque reaction to the operator
- Ergonomically quieted with low vibration
- Minimum oil operation eliminates fogging and product contamination
- Comfortable grip on pistol models

Other Notables

- Transducer control gives higher accuracy
- Certificate issued with every tool for gauge records
- One eCo-Drive or Taper-Lok socket comes standard with each PSI tool to provide the greatest energy transfer.

Numbering and Labeling Example

A M 3 0 P B M A - 40

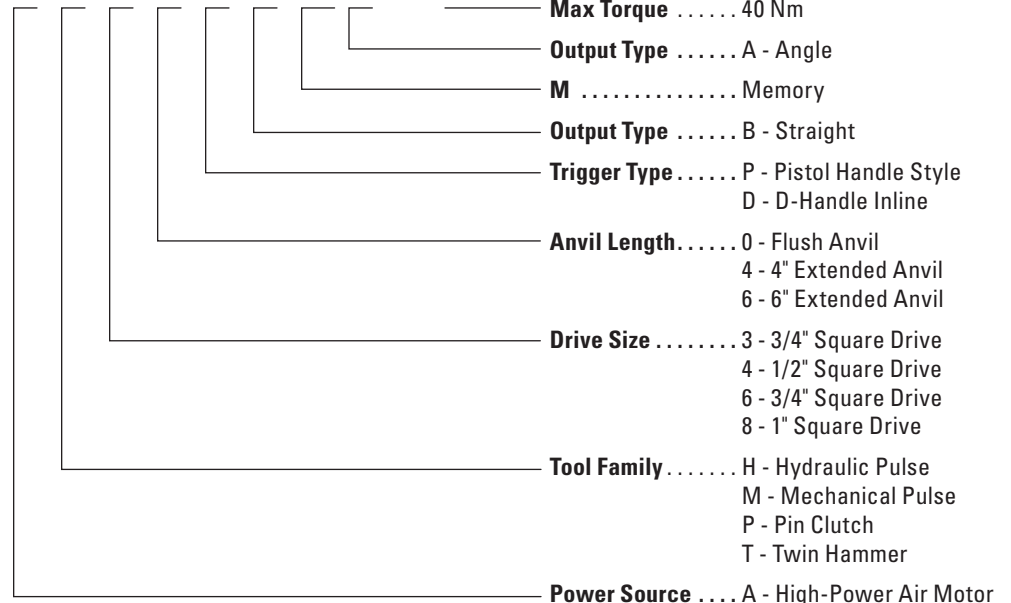

Application of Pulse Tools

Pulse tools offer tremendous advantages over direct-drive nutrunners. They are significantly faster and have virtually no torque reaction, therefore offering one handed operation without torque reaction bars or arms. Pulse tools have a low initial cost and are easy to maintain.

Successful application of pulse tools is dependent upon the proper sizing of the tools and knowledge of which joint conditions are best suited to the different types of pulse tools. Knowledge of which applications or conditions are not suited to pulse tool usage is important to reduce misapplication and the resulting poor performance of the installation.

Generally, pulse tools are designed for free running fasteners and applications that do not require excessive compression of soft materials. Attempting to use pulse tools on high prevailing torque applications will result in longer cycle times and unacceptable tool maintenance requirements.

Whenever a fastener is used to physically draw parts together (which appears as high prevailing torque) the application will cause high wear, frequent maintenance, and long cycle times. For these types of applications a shut-off, or transducerized pulse, tool which is oversized for the torque should be utilized.

Non shut-off or stall pulse tools are best for applications with...

- No significant prevailing torque
- Only free running fasteners - no crimped nuts, tri-lobe bolts or part ghosting
- No self-tapping fasteners
- Best on consistent joint conditions

Shut-off pulse tools are best for applications with...

- Wide variation in joint rates
- Self-threading fasteners
- Significant prevailing torque

Transducer pulse tools are best for applications with...

- Critical torque requirements where data is required
- Wide variation in joint rates
- Self-threading fasteners and significant prevailing torque

Non Shut-Off/Stall Tools

Pro's	Con's
Low initial cost	Difficult to control torque accuracy
Ease of repair	Cycle time controlled by soft joint
Smaller tool	

Shut-Off Pulse Tools

Pro's	Con's
Shorter cycle time	Higher cost & more parts; harder to work on
	Larger and heavier
	15% lower torque per model

Transducer Pulse Tools

Pro's	Con's
Fast cycle time	Must use air
Lighter one-hand operation	Additional maintenance required
No torque reaction	
Lower cost	

PSI Tools Application Reference Chart

PSI Tools (AH, AM, AP & AT) Application Reference Chart

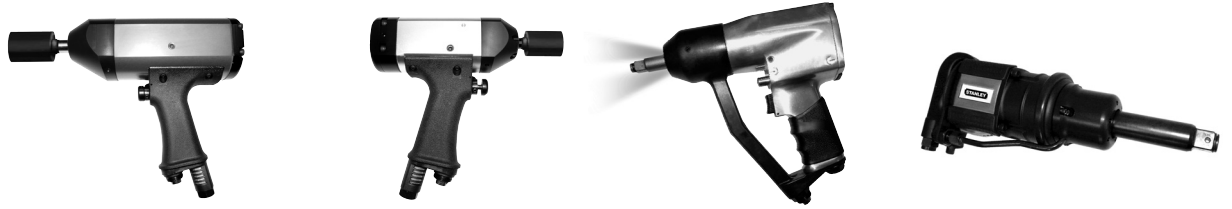

Standard Feature	Hydraulic Pulse AH Series	Mechanical Pulse AM & AM/A Series	Pin Clutch Impact AP Series	Twin-Hammer Impact AT & AT/M Series
Clutch Mechanism	Twin-Blade Oil	Cam Roller	Pin Clutch	Twin Hammer
Energy Transfer	Hydraulic Oil Pressure	Mechanical Cam	Single Hammer / Anvil	Balanced Twin Hammer / Anvil
Torque Range	10 - 120 Nm 8 - 89 lb ft	20 - 450 Nm 15 - 332 lb ft	20 - 225 Nm 15 - 166 lb ft	88 - 2200 Nm 65 - 1623
# of Models in Series	4	5	5	7
Best Use	Critical Applications	Critical Applications	Control / Data Required	Control / Data Required
When to Use	Free Running Bolts	All Joints	Free Running Bolts	All Joints
Joint Type	Hard / Medium Joints	Medium / Soft Joints	Hard / Medium Joints	Medium / Soft Joints
Use on Prevailing Torque	Not Recommended	OK	Light Only	OK
Typical Accuracy	Best	Best	Better	Good
Best Feature	Quiet & Smooth	High Power to Weight Ratio	Fast & Economical	Durability
Maintenance	Oil Change	Check Oil Level	Check Oil Level	Grease Clutch
Preventive Maintenance Recommendation	300,000 Pulse Seconds	6 Months	6 Months	12 Months
Special Feature	Hydraulic Pulse AH Series	Mechanical Pulse AM & AM/A Series	Pin Clutch Impact AP Series	Twin-Hammer Impact AT & AT/M Series
Torque Transducer	Yes	Yes	Yes	Yes
Angle Encoder	n/a	AM/A Series Only	n/a	n/a
Reversible	Yes	Yes	Yes	Yes
Green / Red Status LEDs	Yes	Yes	Yes	Yes
White Headlights	n/a	AM/A Series Only	n/a	Smart Tools Only
Memory	n/a	AM/A Series Only	n/a	Smart Tools Only
Controller to use:	PSI-C	PSI-C for AM < 3/4" SD	PSI-C for < 3/4" SD	PSI-C for < 3/4" SD
		PSI-C/H for AM = 3/4" SD		PSI-C/H for = 3/4" SD
		PSI-C2 for AM/A < 3/4" SD	PSI-C/H for = 3/4" SD	PSI-C/XH for = 1" SD
		PSI-C2/H for AM/A = 3/4" SD		PSI-C2 or PSI-C2/H for Smart Tools

* Torque Range is approximate and will be affected by joint rate, extensions and socket condition.

AH and AM series pulse tools offer excellent ergonomics delivering high torque with virtually no torque reaction. The hydraulic pulse AH series and the mechanical pulse AM series have been changing the industry since 2004. And as with all pulse and impact tools in the PSI family, the AH and AM tools provide operator feedback. Bright Green or Red lights, at the tool output, illuminate the work piece to indicate OK/ NOK cycle status upon completion of the fastening cycle.



- AH series pulse tools use hydraulic fluid to transfer energy to the fastener with the lowest possible noise and vibration levels.
- AM series pulse tools employ a proprietary mechanical mechanism instead of hydraulic fluid to transfer energy to the fastener enabling operation on more intense joint types and duty cycles.

Since the AM series tool uses oil for lubrication only, mechanical pulse tools do not require periodic oil changes reducing maintenance costs significantly. An additional benefit of the mechanical pulse unit is a higher power to weight ratio. For example, the AM tool rated for for 221 Nm weights only 2.6 kg, which is 30% lighter than the leading competitor's comparable hydraulic shutoff tool.

Remember to always use an eCo-Drive Socket with PSI tools. eCo-Drive Socket selection begins on page 133.

Choose a Gemini Hose/Cable from page 127 with a 1/4" fitting at the tool end.

PSI tools run on the PSI-C controller.

Model	Max Torque		Rated Speed	"L" Length		Weight		NPT Inlet	Flow Rate		Output
	Nm	lb ft	RPM	mm	in	kg	lb	in	l/s	CFM	Standard
AH30PB-20	20	15	6,800	149.2	5.88	1.2	2.6	1/4"	17	36	3/8" SD
AH30PB-40	40	30	7,200	165.1	6.50	1.3	3.0	1/4"	17	36	3/8" SD
AM30PB-40	40	30	8,800	162.0	6.38	1.3	3.0	1/4"	12.3	26	3/8" SD
AH30PB-65	65	48	6,800	187.3	7.38	1.5	3.4	1/4"	17	36	3/8" SD
AM30PB-70	70	52	8,800	160.3	6.31	1.4	3.2	1/4"	12.3	26	3/8" SD
AH40PB-120	120	89	6,600	209.5	8.25	2.2	4.8	1/4"	19.8	42	1/2" SD
AM30PB-125	125	93	8,600	190.5	7.50	1.7	3.8	1/4"	15.1	32	3/8" SD
AM40PB-140	140	103	7,200	190.5	7.50	2.0	4.5	1/4"	12.3	26	1/2" SD
AM40PB-221	221	163	6,600	210.0	8.25	2.7	6.0	1/4"	15.1	32	1/2" SD
AM60PB-450	450	332	5,500	301.6	11.88	5.7	12.5	1/4"	15.1	32	3/4" SD

* Torque is approximate and will be affected by joint rate, extensions and socket condition.

Torque Control with Pulse Monitoring (TC/PM)

The most common control strategy for securing threaded fasteners with pulse or impact tools. Pulse Monitoring can detect changes in joint rate for better error proofing of processes.

- Settings:
- Torque Target
 - Torque High/ Torque Low Limits
 - Pulse High/ Pulse Low Limits

This strategy ends when the achieved torque equals the Torque Target value. The achieved peak torque and pulses must be within limits for the fastening cycle to be considered OK.

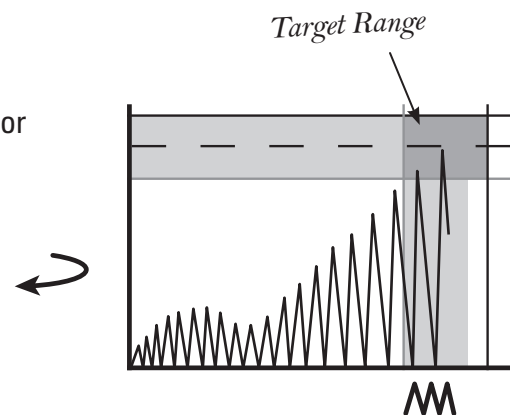

Angle Control AM/A Pulse Tools



STANLEY introduces another industry first! The AM/A series tools with the Absolute Position Sensor (APS) enables Angle Control and Monitoring for the ultimate in pulse tool error-proofing and control. While torque control has become the industry standard for threaded fastening, those operations that demand tighter process control with integrated error-proofing can now turn to the new STANLEY AM/A series pulse tool.

Bright Green or Red lights, at the tool output, illuminate the work piece to indicate OK/NOK cycle status upon completion of the fastening cycle.

White light illuminates the work piece during the fastening cycle.

These AM/A tools have a Tool Memory board which makes them a Smart tool.

Remember to always use an eCo-Drive Socket with PSI tools. eCo-Drive Socket selection begins on page 125.

Choose a Gemini Hose/Cable from page 123 with a 1/4" fitting at the tool end.

PSI tools run on the PSI-C2 controller.

Model	Max Torque		Rated Speed	"L" Length		Weight		NPT Inlet	Flow Rate		Output
	Nm	lb ft	RPM	mm	in	kg	lb	in	l/s	CFM	Standard
AM30PBMA-40	40	30	8,800	177.8	7.00	1.3	3.0	1/4"	12.3	26	3/8" SD
AM30PBMA-70	70	52	8,800	177.8	7.00	1.4	3.2	1/4"	12.3	26	3/8" SD
AM40PBMA-140	140	103	7,200	197.0	7.75	2.1	4.6	1/4"	12.3	26	1/2" SD
AM40PBMA-220	220	162	6,600	228.6	9.00	2.8	6.2	1/4"	15.1	32	1/2" SD
AM60PBMA-450	450	332	5,500	318.0	12.50	5.8	12.8	1/4"	15.1	32	3/4" SD

*** Torque Range is approximate and will be affected by joint rate, extensions and socket condition.**

Angle Control with Torque Monitoring (AC/TM)

This controls the amount of fastener rotation after a Snug Torque value. Angle Control can determine the component positions and fastener depths for better error proofing of processes.

- Settings:
- Angle Target
 - Angle High/ Angle Low Limits
 - Torque High/ Torque Low Limits

This strategy ends when the achieved angle equals the Angle Target value. the achieved peak torque and angle must be within limits for the fastening cycle to be considered OK.

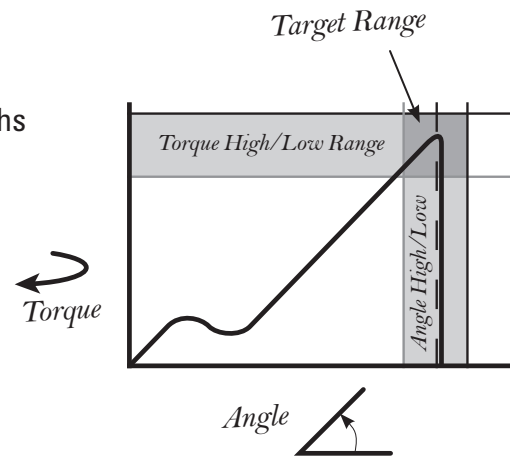

Another industry first! The new AP series impact tools feature an internal torque transducer. The AP series offers the power of an impact tool optimized for operator comfort by delivering smooth and accurate high speed performance across a wide range of free running fasteners on hard to medium joint rates with light to medium duty cycles.



All of this with virtually no torque reaction!

Bright Green or Red lights, at the tool output, illuminate the work piece to indicate OK/NOK cycle status upon completion of the fastening cycle

Model	Max Torque		Rated Speed	"L" Length		Weight		NPT Inlet	Flow Rate		Output
	Nm	ft/lb	RPM	mm	in	kg	lb	in	l/s	CFM	Standard
AP30PB-40	40	30	9,000	158.8	6.25	0.9	2.0	1/4"	14.2	30	3/8" SD
AP30PB-115	115	85	8,800	190.5	4.50	1.2	2.6	1/4"	14.2	30	3/8" SD
AP40PB-225	225	166	7,800	228.6	9.00	2.8	6.2	1/4"	14.2	30	1/2" SD

*Torque Range is approximate and will be affected by joint rate, extensions and socket condition.

Remember to always use a Taper-Lok™ Socket with these tools. Taper-Lok™ Socket selection begins on page 140.

Choose a Gemini Hose/Cable from page 123 with correct size fitting at the tool end.

PSI tools run on the PSI-C or PSI-C/H controller. Target Range

Torque Control with Pulse Monitoring (TC/PM)

The most common control strategy for securing threaded fasteners with pulse or impact tools. Pulse Monitoring can detect changes in joint rate for better error proofing of processes.

- Settings:
- Torque Target
 - Torque High/ Torque Low Limits
 - Pulse High/ Pulse Low Limits

This strategy ends when the achieved torque equals the Torque Target value. The achieved peak torque and pulses must be within limits for the fastening cycle to be considered OK.

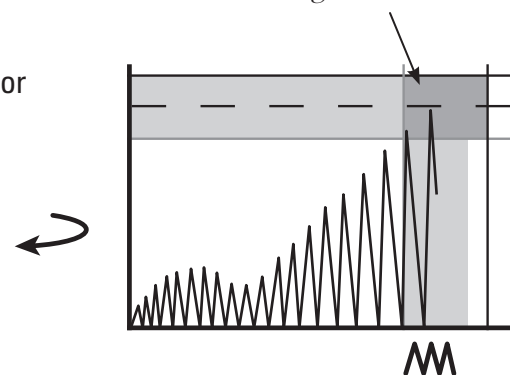

Heavy Duty AT Impact Tools

STANLEY is proud to offer the **ONLY** heavy duty transducerized impact tool with all the power and performance advantages of a Twin Hammer and the control and reporting capability of a transducerized tool. The AT series offers the power necessary for the most demanding applications with the soft and prevailing joint rates and the most intense duty cycles.

- Bright Green or Red lights, at the tool output, illuminate the work piece to indicate OK/ NOK cycle status upon completion of the fastening cycle



Remember to always use a Taper-Lok™ Socket with these tools. Taper-Lok™ Socket selection begins on page 140.

Choose a Gemini Hose/ Cable from page 123 with correct size fitting at the tool end.

Model	Max Torque		Rated Speed	"L" Length		Weight		NPT Inlet	Flow Rate		Output
	Nm	lb ft	RPM	mm	in	kg	lb	in	l/s	CFM	Standard
AT40PB-175	175	129	10,000	192	7.56	1.6	3.6	1/4	16.5	35	1/2 SD
AT40PB-335	335	247	7,500	237	9.38	2.7	6.0	1/4	16.5	35	1/2 SD
AT60DB-675	675	498	5,500	282	11.13	6.4	14.2	3/8	28.3	60	3/4 SD
AT60PB-675	675	498	5,500	381	15.00	6.6	14.5	3/8	28.3	60	3/4 SD
AT64DB-675	675	498	5,500	374	14.75	6.7	14.8	1/2	28.3	60	3/4 SD
AT64PB-675	675	498	5,500	468	18.44	7.2	15.8	1/2	28.3	60	3/4 SD
AT84DB-1300	1300	959	4,500	487	19.13	11.8	26.0	1/2	30.7	65	1 SD
AT86DB-2200	2200	1623	4,200	630	24.75	17.2	37.8	1/2	41.1	87	1 SD

* Torque Range is approximate and will be affected by joint rate, extensions and socket condition.

These AT tools have a Tool Memory board which makes them a Smart tool.

Model	Max Torque Nm *		Rated Speed	"L" Length		Weight		NPT Inlet	Flow Rate		Output
	Hard	Soft	RPM	mm	in	kg	lb	in	l/s	CFM	Standard
AT40PBM-175	175	129	10,000	192	7.56	1.6	3.6	1/4	16.5	35	1/2 SD
AT40PBM-335	335	247	7,500	237	9.38	2.7	6.0	1/4	16.5	35	1/2 SD
AT60DBM-675	675	498	5,500	282	11.13	6.4	14.2	3/8	28.3	60	3/4 SD
AT60PBM-675	675	498	5,500	381	15.00	6.6	14.5	3/8	28.3	60	3/4 SD
AT64DBM-675	675	498	5,500	374	14.75	6.7	14.8	1/2	28.3	60	3/4 SD
AT64PBM-675	675	498	5,500	468	18.44	7.2	15.8	1/2	28.3	60	3/4 SD
AT84DBM-1300	1300	959	4,500	487	19.13	11.8	26.0	1/2	30.7	65	1 SD
AT86DBM-2200	2200	1623	4,200	630	24.75	17.2	37.8	1/2	41.1	87	1 SD

* Torque Range is approximate and will be affected by joint rate, extensions and socket condition.

Target Range

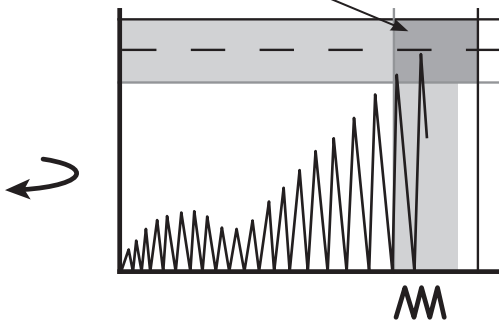

The Smart tools run on the PSI-C2 controller.

These tools with a 1/2" NPT inlet run on the High Flow (/H) controller except the AT84DB(M)-1300 and AT86DB(M)-2200 which run on the X-tra High Flow (/XH) controller.

Example: An AT84DBM-1300 would need the PSI-C2/XH controller and the AT64DB-675 would need the PSI-C/H controller.

Gemini Hose/ Cable

Gemini hoses have the electric transducer cable bonded directly to the air hose. No tie wraps or tape required.

These are used with the **PSI-C controller and PSI tools.**

Simple. Low maintenance and inexpensive cables are available for use with air tools on PSI controllers.

	Hose/Cable Part No.	Length	Fitting at Controller	Fitting at Tool	Hose ID Size	Hose Type
Model		meters	in	in	in	
PSI-C & PSI-C2	24C500503	3	3/8	1/4	3/8	Straight
PSI-C & PSI-C2	24C500505	5	3/8	1/4	3/8	
PSI-C & PSI-C2	24C500508	8	3/8	1/4	3/8	
PSI-C & PSI-C2	24C500511	11	3/8	1/4	3/8	
PSI-C & PSI-C2	24C500603	3	3/8	3/8	3/8	
PSI-C & PSI-C2	24C500605	5	3/8	3/8	3/8	
PSI-C & PSI-C2	24C500608	8	3/8	3/8	3/8	
PSI-C & PSI-C2	24C500611	11	3/8	3/8	3/8	
PSI-C & PSI-C2	24C500803	3	3/8	1/4	3/8	Coil
PSI-C & PSI-C2	24C500805	5	3/8	1/4	3/8	
PSI-C & PSI-C2	24C500808	8	3/8	1/4	3/8	
PSI-C & PSI-C2	24C500905	5	3/8	3/8	3/8	
PSI-C & PSI-C2	24C500908	8	3/8	3/8	3/8	
PSI-C/H & PSI-C2/H	24C505303	3	1/2	3/8	1/2	Straight
PSI-C/H & PSI-C2/H	24C505305	5	1/2	3/8	1/2	
PSI-C/H & PSI-C2/H	24C505308	8	1/2	3/8	1/2	
PSI-C/H & PSI-C2/H	24C505311	11	1/2	3/8	1/2	
PSI-C/H & PSI-C2/H	24C500703	3	1/2	1/2	1/2	
PSI-C/H & PSI-C2/H	24C500705	5	1/2	1/2	1/2	
PSI-C/H & PSI-C2/H	24C500708	8	1/2	1/2	1/2	
PSI-C/H & PSI-C2/H	24C500711	11	1/2	1/2	1/2	
PSI-C/H & PSI-C2/H	24N500044	5	1/2	3/8	1/2	Coil
PSI-C/XH & PSI-C2/XH	24C100100	5	1	1/2	1	Straight
PSI-C/XH & PSI-C2/XH	24C100101	8	1	1/2	1	



JED Lite Hose with Swivel at Tool End

JED Lite hoses have a tiny wire inserted into the hose presenting a red and green LED at the tool end to provide operator feedback of the fastening cycle status. **These are used with the PSI-Q or PSI-Qc qualifiers.**

	Hose/Cable Part No.	Length	Fitting at Controller	Fitting at Tool	Hose ID Size	Hose Type
Model		meters	in	in	in	
PSI-Q & PSI-Qc	24C500102	2	3/8	1/4	3/8	Straight
PSI-Q & PSI-Qc	24C500105	5	3/8	1/4	3/8	
PSI-Q & PSI-Qc	24C500108	8	3/8	1/4	3/8	
PSI-Q & PSI-Qc	24C500202	2	3/8	3/8	3/8	
PSI-Q & PSI-Qc	24C500205	5	3/8	3/8	3/8	
PSI-Q & PSI-Qc	24C500208	8	3/8	3/8	3/8	
PSI-Q/H & PSI-Qc/H	24C500305	5	1/2	3/8	1/2	
PSI-Q/H & PSI-Qc/H	24C500308	8	1/2	3/8	1/2	

PSI Tool & Cable Configurations

Choose Your Hose/Cable

Step 1: Determine the Tool Inlet size.

Step 2: Determine the Controller Inlet Size.

Step 3: Select the appropriate cable based on the tool and controller fitting sizes.

Note: AM series tools with 3/4" Square Drives may require the usage of a High Flow controller. A 1/4" to 3/8" NPT adaptor is required at the tool end to utilize the appropriate cable/hose.

Tool Inlet: 1/4" NPT
AH / AM / AP / AT Series



24C5005[##]
Gemini Hose/Cable, Straight, 1/4" - 3/8", 3/8" ID
[##] = 03, 05, 08, or 11 meters

24C5008[##]
Gemini Hose/Cable, Coiled, 1/4" - 3/8", 3/8" ID
[##] = 03, 05, or 08 meters



24C5006[##]
Gemini Hose/Cable, Straight, 3/8" - 3/8", 3/8" ID
[##] = 03, 05, 08, or 11 meters

Tool Inlet: 3/8" NPT
AP / AT Series



24C5009[##]
Gemini Hose/Cable, Coiled, 3/8" - 3/8", 3/8" ID
[##] = 05, or 08 meters



Tool Inlet: 3/8" NPT
AM* / AP / AT Series



24C5053[##]
Gemini Hose/Cable, Straight, 3/8" - 1/2", 1/2" ID
[##] = 03, 05, 08, or 11 meters

24N500044
Gemini Hose/Cable, Coiled, 3/8" - 1/2", 1/2" ID
5 meters



Tool Inlet: 1/2" NPT
AT Series



24C5007[##]
Gemini Hose/Cable, Straight, 1/2" - 1/2", 1/2" ID
[##] = 03, 05, 08, or 11 meters

24C1001[##]
Gemini Hose/Cable, Straight, 1/2" - 1", 1" ID
[##] = 00 for 5 meters or 01 for 8 meters

Controller Inlet: 3/8" NPT
PSI-C PSI-C2



Controller Inlet: 1/2" NPT
PSI-C/H PSI-C2/H



Controller Inlet: 1" NPT
PSI-C/XH PSI-C2/XH



M30 & M40 PRIME MOVER MOTORS

FIXTURED-PNEUMATIC - NO MOUNT

9 – 87 Nm (6.5 – 64 lb ft)

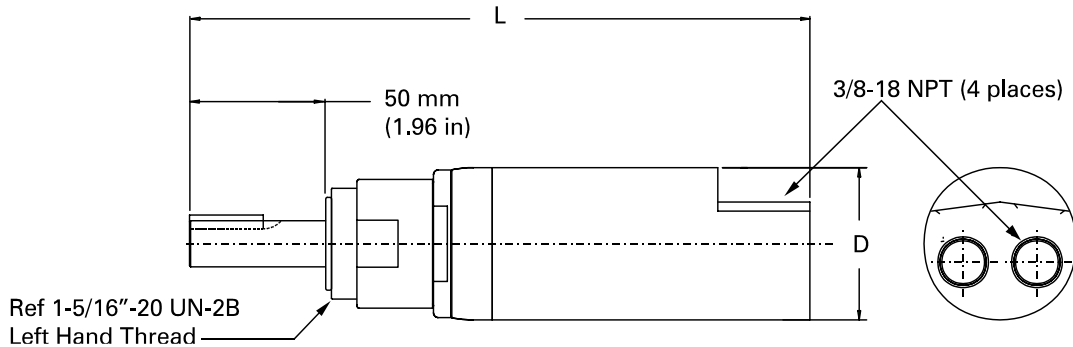

Simple Design And Sturdy Construction Provide Long Life And Low Maintenance Costs

- Regulating of the air pressure adjusts speed and power
- High power per pound ratio minimizes required space
- Air motor may be stalled repeatedly with no damage to the motor
- No spark hazard allows air motor use in explosive atmospheres or near flammable material
- Air motors are not susceptible to thermal breakdown in high temperature areas
- Continuous duty operation maximizes production use

M30/40 Prime Mover Motors give reliable and economical power for production operations.

STANDARD CONFIGURATION:

M30 Output Shaft: 13mm (1/2") diameter x 25mm (1") long with 3 x 3 x 16 mm (1/8" x 1/8" x 5/8") long keyway

M40 Output Shaft: 16mm (5/8") diameter x 44mm (1.75") long with 5 x 5 x 25 mm (3/16" x 3/16" x 1") long keyway

Min Hose: M30: 5/16" ID, Air Inlet 1/4" NPT (1/4" ISO Inlet Option); 10 l/s (20 ft³/m) M40: 1/2" ID, Air Inlet 3/8" NPT (3/8" ISO Inlet Option); 20 l/s (40 ft³/m)

MODEL	FREE SPEED	STALL TORQUE		RATED HP	MAX RPM	TORQUE @MAX HP		"L" LENGTH		"D" DIAMETER		WEIGHT	
	RPM	Nm	lb ft	H.P.	RPM	Nm	lb ft	mm	in	mm	in	kg	lb
NON-REVERSIBLE M30													
M30-16	1650	9	6.5	0.5	845	4	3	157	6.8	41	1.62	1.2	2.6
NON-REVERSIBLE M40													
M40-16	1600	21	16	1.2	820	11	8	191	7.5	52	2.06	2	4.3
M40-5	500	65	48		265	33	24	216	8.5			2.2	4.7
M40-4	375	87	64		200	43	32						
REVERSIBLE M40R													
M40R-3	300	80	59	0.9	165	40	29	216	8.5	52	2.06	2.2	4.7

ADDITIONAL COST OPTIONS:

- Reverse Rotation (Add 'RR' MODEL eg: M40RR-5)
- Special Gearing

M40 PRIME MOVER MOTORS-FLANGE MOUNTED

FIXTURED-PNEUMATIC –FLANGE MOUNTED

5.5 – 32 Nm (4 – 24 lb ft)

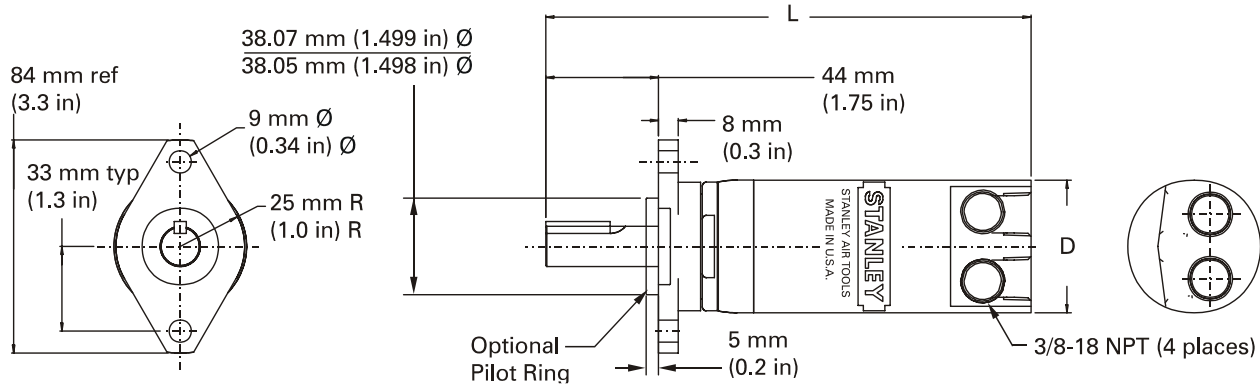

Simple Design And Sturdy Construction Provide Long Life And Low Maintenance Costs

- Regulating of the air pressure adjusts speed and power
- High power per pound ratio minimizes required space
- Air motor may be stalled repeatedly with no damage to the motor
- No spark hazard allows air motor use in explosive atmospheres or near flammable material
- Air motors are not susceptible to thermal breakdown in high temperature areas
- Continuous duty operation maximizes production use

M40F Prime Mover Motors give reliable and economical power for flange mounted motor geometry.

STANDARD CONFIGURATION:

M40 Output Shaft: 16mm (5/8") diameter x 44mm (1.75") long with 5 x 5 x 25 mm (3/16" x 3/16" x 1") long keyway

Min Hose: M30: 5/16" ID, Air Inlet 1/4" NPT (1/4" ISO Inlet Option); 10 l/s (20 ft³/m) M40: 1/2" ID, Air Inlet 3/8" NPT (3/8" ISO Inlet Option); 20 l/s (40 ft³/m)

MODEL	FREE SPEED	STALL TORQUE		RATED HP	MAX RPM	TORQUE @MAX HP		"L" LENGTH		"D" DIAMETER		WEIGHT	
	RPM	Nm	lb ft	H.P.	RPM	Nm	lb ft	mm	in	mm	in	kg	lb
NON-REVERSIBLE M40F													
M40F-37	3700	8.5	6	1.2	1875	4.5	3.4	191	7.5	52	2.06	2	4.3
M40F-26	2600	12.5	9		1325	6.5	5						
REVERSIBLE M40FR													
M40FR-13	1300	19.5	14	0.9	670	10	7	191	7.5	52	2.06	2	4.3
M40FR-7	750	32	24		395	16.5	12						

ADDITIONAL COST OPTIONS:

- M4005 Pilot Ring for M40F
- Reverse Rotation
- Special Gearing

M40 PRIME MOVER MOTORS-BASE MOUNTED

FIXTURED-PNEUMATIC – BASE MOUNTED

14 – 59 Nm (19 – 80 lb ft)

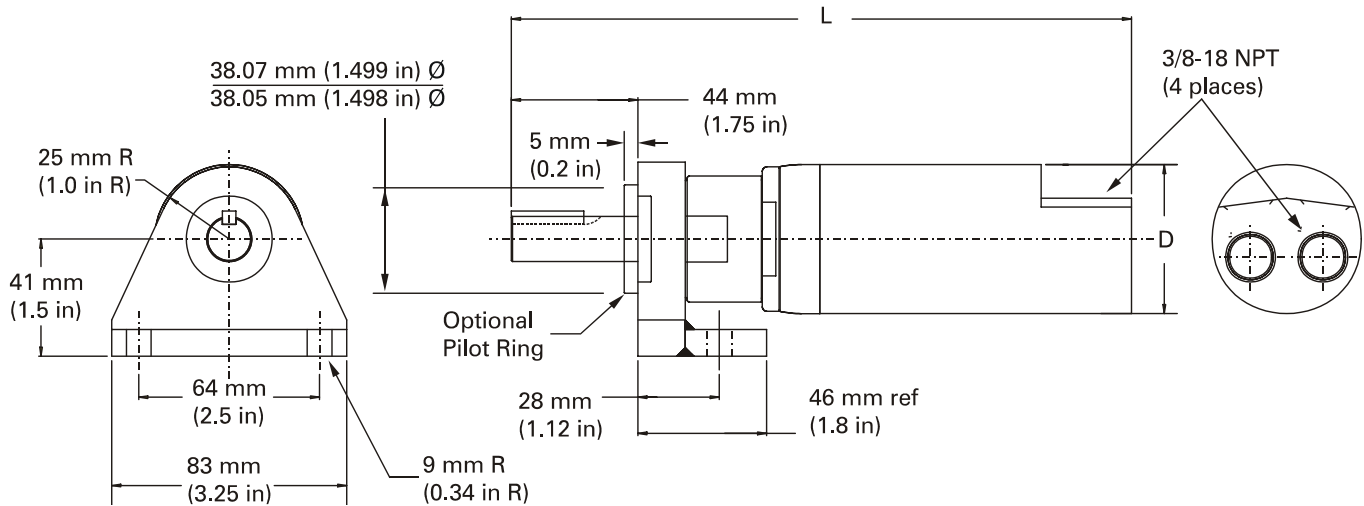

Simple Design And Sturdy Construction Provide Long Life And Low Maintenance Costs

- Regulating of the air pressure adjusts speed and power
- High power per pound ratio minimizes required space
- Air motor may be stalled repeatedly with no damage to the motor
- No spark hazard allows air motor use in explosive atmospheres or near flammable material
- Air motors are not susceptible to thermal breakdown in high temperature areas
- Continuous duty operation maximizes production use

M40B Prime Mover Motors give reliable and economical power for base mounted motor geometry.
STANDARD CONFIGURATION:
 Output Shaft: 16mm (5/8") diameter x 44mm (1.75") long with 5 x 5 x 25 mm (3/16" x 3/16" x 1") long keyway

Min Hose: M30: 5/16" ID, Air Inlet 1/4" NPT (1/4" ISO Inlet Option); 10 l/s (20 ft³/m) M40: 1/2" ID, Air Inlet 3/8" NPT (3/8" ISO Inlet Option); 20 l/s (40 ft³/m)

MODEL	FREE SPEED	STALL TORQUE		RATED HP	MAX RPM	TORQUE @MAX HP		"L" LENGTH		"D" DIAMETER		WEIGHT	
	RPM	Nm	lb ft	H.P.	RPM	Nm	lb ft	mm	in	mm	in	kg	lb
REVERSIBLE M40BR													
M40BR-13	1300	19	14	0.92	670	10	7	191	7.5	52	2.06	2	4.3
M40BR-7	750	32	24		395	16.5	12	216	8.5			2.2	4.7
M40BR-3	300	80	59		165	40	29						

ADDITIONAL COST OPTIONS:

- M4005 Pilot Ring for M40BR
- Reverse Rotation
- Special Gearing

DC Electric Headlight Aim Tools

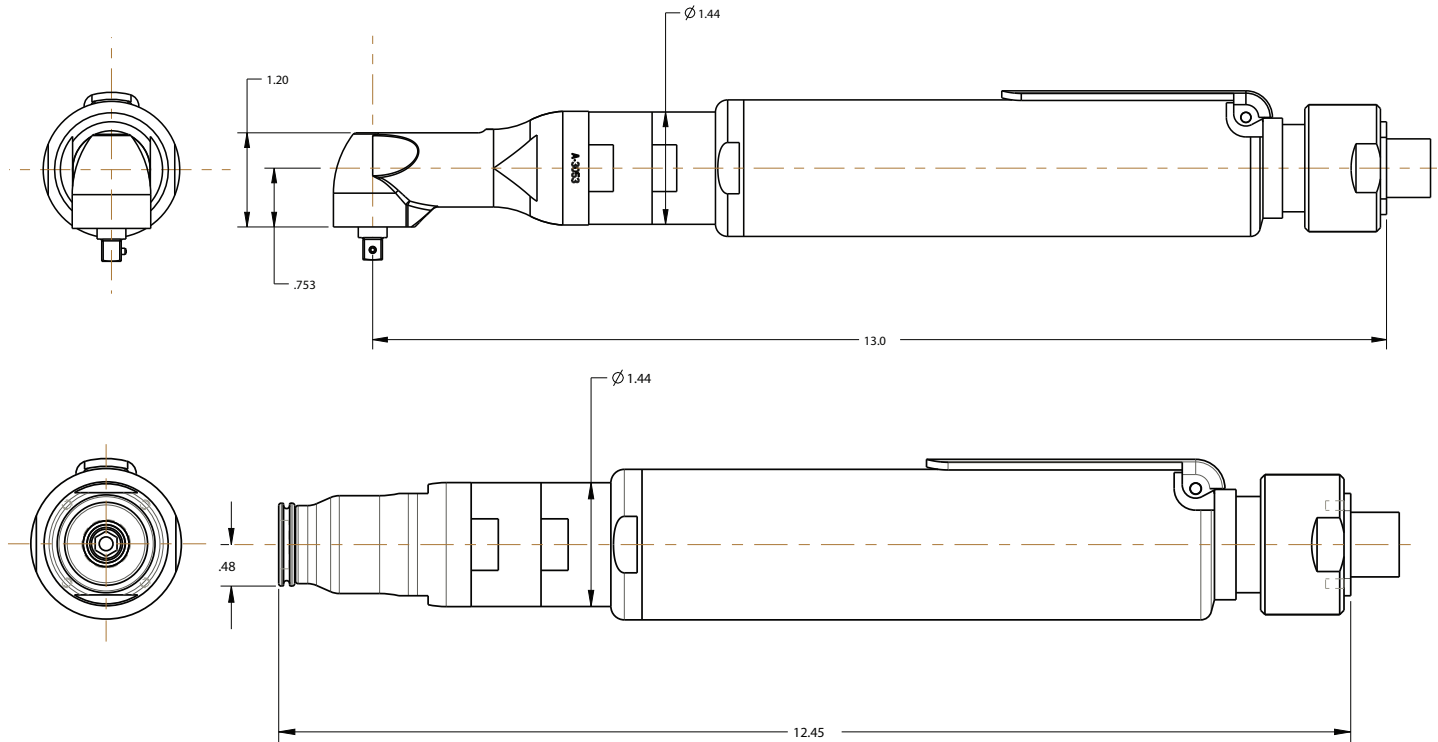

Stanley offers durable tools for production headlight aiming systems with models that fit most alignment systems. In production, the operator typically positions one tool each on the horizontal and vertical adjusting screws. The headlight aiming system controls the direction and rotation of the tools to adjust the headlight.

Torque capacity, not critical to the application, ranges from 3 to 11 Nm (24 to 94 lb-in). Each tool includes the specified connector either on the tool end or specified system interface cable.

TOOL DURABILITY MINIMIZES PRODUCTION DOWN TIME

- One-piece high strength T7075 aluminum housing as rugged as steel.
- Tool weighs 1.8 Kg (4 lb) excluding crowfoots.

A RANGE OF MODELS TO FIT YOUR SYSTEM

- Connectors and pin-outs that fit different alignment systems.
- Straight, Right Angle and Crowfoot heads.

Model	Rated Speed		Cable Length		Connector	Drive	Output
	RPM	M	ft				
S30-372	149	3	10		AMP 97-3106A-14S-6P	1/4" SD	Right Angle
S30-388	149	0	0		AMP 97-3102A-14S-6P(115)	1/4" SD	Right Angle
S30-390	224	0	0		AMP 97-3102A-14S-P(115)	1/4" Hex	Inline
S30-351	149	3.6	12		AMP 97-3106A-14S-5P	1/4" SD	Right Angle
S30-405	224	3	10		SINE A510-3Y-A300	1/4" Hex	Inline

Crowfoot outputs are available upon request.



Choose Your Socket

The New eCoDrive™ Sockets Provide Efficient & Safe Energy Transfer!

New sockets for Pulse and Impact tools from STANLEY Assembly Technologies deliver more torque with less vibration. All STANLEY Assembly Technologies pulse tools conform to the Japanese/ Asian standard for sleeve type guided sockets and extensions.

STANLEY Assembly Technologies' eCoDrive™ ergonomic sockets and extensions will greatly improve productivity by increasing torque accuracy, reduce torque loss, and improve operator comfort.

An O-ring inside the drive end of eCoDrive™ sockets and extensions creates a fit that is perfectly snug with the pulse tool anvil. This controlled alignment eliminates the vibration and rattle normally created by the loose fit, and wobble, of standard pulse tool sockets and extensions. No vibration or wobble means a higher capability as more torque is delivered consistently to the fastener with reduced operator fatigue and injury.

Anti-mar, free-spinning, protection covers made of Delrin® High Performance, Low Wear, Low Friction Grade Acetal Resin are optional for all eCoDrive™ sockets and extensions.

One eCo-Drive or Taper-Lok socket comes standard with each PSI tool to provide the greatest energy transfer.

eCoDrive™ Fast-Lead 6-Point Sockets for Pulse Tools

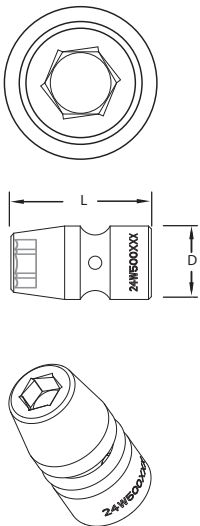

3/8" Drive	Length		Diameter		Part Number	Socket With Sleeve	Sleeve	Dowel Pin	External O-Ring
	Size (mm)	mm	in	mm					
8	37.85	1.49	19.78	0.78	24W500084	24W510060	24W520003	24R501280	24R501270
10	37.85	1.49	19.78	0.78	24W500085	24W510061			
12	37.85	1.49	19.78	0.78	24W500086	24W510062			
13	37.85	1.49	19.78	0.78	24W500087	24W510063			
14	37.85	1.49	19.78	0.78	24W500141	24W510117	24W520004	24R501281	24R501271
15	46.74	1.84	25.15	0.99	24W500121	24W510097			
16	46.74	1.84	25.15	0.99	24W500124	24W510100			
17	46.74	1.84	25.15	0.99	24W500127	24W510103			
18	46.74	1.84	28.35	1.12	24W500130	24W510106	24W520005	24R501284	24R501272
19	46.74	1.84	28.35	1.12	24W500133	24W510109			

eCoDrive™ Fast-Lead 6-Point Sockets for Pulse Tools

3/8" Drive	Length		Diameter		Part Number	Socket With Sleeve	Sleeve	Dowel Pin	External O-Ring
	Size (in)	mm	in	mm					
3/8	37.85	1.49	19.78	0.78	24W500112	Contact Us for more info	24W520003	24R501280	24R501270
7/16	37.85	1.49	19.78	0.78	24W500178				
1/2	37.85	1.49	19.78	0.78	24W500113				
9/16	37.85	1.49	19.78	0.78	24W500115		24W520004		

1/2" Drive	Length		Diameter		Part Number	Socket With Sleeve	Sleeve	Dowel Pin	External O-Ring
	Size (mm)	mm	in	mm					
13	46.74	1.84	25.15	0.99	24W500112	24W510088	24W520019	24R501283	24R501271
14	46.74	1.84	25.15	0.99	24W500178	24W510135			
15	46.74	1.84	25.15	0.99	24W500113	24W510089			
16	46.74	1.84	25.15	0.99	24W500114	24W510090			
17	46.74	1.84	28.35	1.12	24W500115	24W510091	24W500020	24R501279	24R501276
18	46.74	1.84	28.35	1.12	24W500116	24W510092			
19	46.74	1.84	28.35	1.12	24W500117	24W510093			
20	46.74	1.84	32.97	1.30	24W500118	24W510094			
21	46.74	1.84	32.97	1.30	24W500119	24W510095	24W500021	24R501285	24R501272
22	46.74	1.84	32.97	1.30	24W500120	24W510096			

1/2" Drive	Length		Diameter		Part Number	Socket With Sleeve	Sleeve	Dowel Pin	External O-Ring
	Size (in)	mm	in	mm					
9/16	46.74	1.84	25.15	0.99	24W500284	Contact Us for more info	24W520019	24R501283	24R501271
5/8	46.74	1.84	25.15	0.99	24W500287				
11/16	46.74	1.84	28.35	1.12	24W500290		24W500020	24R501279	24R501276
3/4	46.74	1.84	28.35	1.12	24W500293				
13/16	46.74	1.84	32.97	1.30	24W500296		24W500021	24R501285	24R501272
7/8	46.74	1.84	32.97	1.30	24W500299				
15/16	46.74	1.84	39.37	1.55	24W500302				
1	46.74	1.84	39.37	1.55	24W500305				



eCoDrive™ Fast-Lead Deep 6-Point Sockets for Pulse Tools

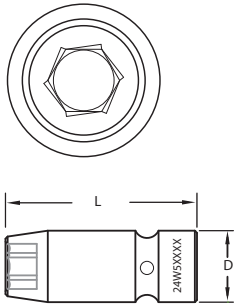

3/8" Drive	Length		Diameter		Part Number	Socket With Sleeve	Separate Sleeve	Dowel Pin	External O-Ring
	Size (mm)	mm	in	mm					
8	59.44	2.34	19.81	0.78	24W500107	24W510083	24W520006	24R501280	24R501270
10	59.44	2.34	19.81	0.78	24W500108	24W510084			
12	59.44	2.34	19.81	0.78	24W500109	24W510085			
13	59.44	2.34	19.81	0.78	24W500110	24W510086			
14	68.58	2.70	25.15	0.99	24W500254	Contact Us	24W520007	24R501281	24R501271
15	68.58	2.70	25.15	0.99	24W500122	24W510098			
16	68.58	2.70	25.15	0.99	24W500125	24W510101			
17	68.58	2.70	25.15	0.99	24W500128	24W510104			
18	74.17	2.92	28.35	1.12	24W500131	24W510107	24W520008	24R501284	24R501272
19	74.17	2.92	28.35	1.12	24W500134	24W510110			

3/8" Drive	Length		Diameter		Part Number	Socket With Sleeve	Separate Sleeve	Dowel Pin	External O-Ring
	Size (in)	mm	in	mm					
5/16	59.44	2.34	19.81	0.78	24W500443	Contact Us for more info	24W520006	24R501280	24R501270
3/8	59.44	2.34	19.81	0.78	24W500273				
7/16	59.44	2.34	19.81	0.78	24W500276				
1/2	59.44	2.34	19.81	0.78	24W500279		24W520007	24R501281	24R501271
9/16	68.58	2.70	25.15	0.99	24W500282				
3/4	74.17	2.92	28.35	1.12	24W500448				

1/2" Drive	Length		Diameter		Part Number	Socket With Sleeve	Separate Sleeve	Dowel Pin	External O-Ring
	Size (mm)	mm	in	mm					
13	68.58	2.70	25.15	0.99	24W500097	24W510073	24W520022	24R501283	25R501271
14	68.58	2.70	25.15	0.99	24W500179	24W510136			
15	68.58	2.70	25.15	0.99	24W500098	24W510074			
16	68.58	2.70	25.15	0.99	24W500099	24W510075			
17	74.17	2.92	28.35	1.12	24W500100	24W510076	24W520023	24R501279	25R501276
18	74.17	2.92	28.35	1.12	24W500101	24W510077			
19	74.17	2.92	28.35	1.12	24W500102	24W510078			
20	82.55	3.25	32.97	1.30	24W500103	24W510079	24W520024	24R501285	24R501272
21	82.55	3.25	32.97	1.30	24W500104	24W510080			
22	82.55	3.25	32.97	1.30	24W500111	24W510087			

1/2" Drive	Length		Diameter		Part Number	Socket With Sleeve	Separate Sleeve	Dowel Pin	External O-Ring
	Size (in)	mm	in	mm					
9/16	68.58	2.70	25.15	0.99	24W500285	Contact Us for more info	24W520022	24R501283	25R501271
5/8	68.58	2.70	25.15	0.99	24W500288				
11/16	74.17	2.92	28.35	1.12	24W500291		24W520023	24R501279	25R501276
3/4	74.17	2.92	28.35	1.12	24W500294				
13/16	82.55	3.25	32.97	1.30	24W500297	24W520024	24R501285	24R501272	
7/8	82.55	3.25	32.97	1.30	24W500300				
15/16	94.234	3.71	39.37	1.55	24W500303				
1	94.234	3.71	39.37	1.55	24W500306				

eCoDrive™ Hex, Deep, Sliding Magnet 6-Point Sockets for Pulse Tools

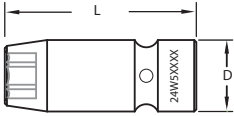
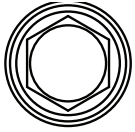

3/8" Drive	Length		Diameter		Part Number	Socket With Sleeve	Separate Sleeve	Dowel Pin	External O-Ring
	Size (mm)	mm	in	mm					
8	59.44	2.34	19.81	0.78	24W500105	24W510081	24W520006	24R501280	24R501270
10	59.44	2.34	19.81	0.78	24W500106	24W510082			
12	59.44	2.34	19.81	0.78	24W500082	24W510058			
13	59.44	2.34	19.81	0.78	24W500083	24W510059			
14	68.58	2.70	25.15	0.99	24W500255	Contact Us	24W520007	24R501281	24R501271
15	68.58	2.70	25.15	0.99	24W500123	24W510099			
16	68.58	2.70	25.15	0.99	24W500126	24W510102			
17	68.58	2.70	25.15	0.99	24W500129	24W510105			
18	74.17	2.92	28.35	1.12	24W500132	24W510108	24W520008	24R501284	24R501272
19	74.17	2.92	28.35	1.12	24W500135	24W510111			

1/2" Drive	Length		Diameter		Part Number	Socket With Sleeve	Separate Sleeve	Dowel Pin	External O-Ring
	Size (mm)	mm	in	mm					
13	68.58	2.70	25.15	0.99	24W500088	24W510064	24W520022	24R501283	24R501271
14	68.58	2.70	25.15	0.99	24W500137	24W510113			
15	68.58	2.70	25.15	0.99	24W500089	24W510065			
16	68.58	2.70	25.15	0.99	24W500090	24W510066	24W520023	24R501279	24R501276
17	74.17	2.92	28.35	1.12	24W500091	24W510067			
18	74.17	2.92	28.35	1.12	24W500092	24W510068			
19	74.17	2.92	28.35	1.12	24W500093	24W510069	24W520024	24R501285	24R501272
20	82.55	3.25	32.97	1.30	24W500094	24W510070			
21	82.55	3.25	32.97	1.30	24W500095	24W510071			
22	82.55	3.25	32.97	1.30	24W500096	24W510072			



eCoDrive™ Hex, Deep, Sliding Magnet 6-Point Sockets for Pulse Tools

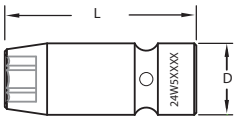
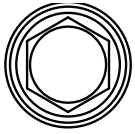

3/8" Drive	Length		Diameter		Part Number	Socket With Sleeve	Separate Sleeve	Dowel Pin	External O-Ring
	Size (mm)	mm	in	mm					
8	59.44	2.34	19.81	0.78	24W500105	24W510081	24W520006	24R501280	24R501270
10	59.44	2.34	19.81	0.78	24W500106	24W510082			
12	59.44	2.34	19.81	0.78	24W500082	24W510058			
13	59.44	2.34	19.81	0.78	24W500083	24W510059			
14	68.58	2.70	25.15	0.99	24W500255	Contact Us	24W520007	24R501281	24R501271
15	68.58	2.70	25.15	0.99	24W500123	24W510099			
16	68.58	2.70	25.15	0.99	24W500126	24W510102			
17	68.58	2.70	25.15	0.99	24W500129	24W510105			
18	74.17	2.92	28.35	1.12	24W500132	24W510108	24W520008	24R501284	24R501272
19	74.17	2.92	28.35	1.12	24W500135	24W510111			

1/2" Drive	Length		Diameter		Part Number	Socket With Sleeve	Separate Sleeve	Dowel Pin	External O-Ring
	Size (mm)	mm	in	mm					
13	68.58	2.70	25.15	0.99	24W500088	24W510064	24W520022	24R501283	24R501271
14	68.58	2.70	25.15	0.99	24W500137	24W510113			
15	68.58	2.70	25.15	0.99	24W500089	24W510065			
16	68.58	2.70	25.15	0.99	24W500090	24W510066	24W520023	24R501279	24R501276
17	74.17	2.92	28.35	1.12	24W500091	24W510067			
18	74.17	2.92	28.35	1.12	24W500092	24W510068			
19	74.17	2.92	28.35	1.12	24W500093	24W510069	24W520024	24R501285	24R501272
20	82.55	3.25	32.97	1.30	24W500094	24W510070			
21	82.55	3.25	32.97	1.30	24W500095	24W510071			
22	82.55	3.25	32.97	1.30	24W500096	24W510072			

eCoDrive™ Hex, Short Magnetic Sidewall 6-Point Sockets for Pulse Tools

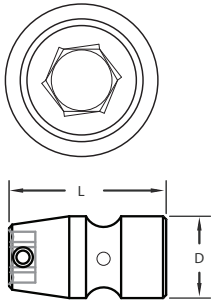

3/8" Drive	Length		Diameter		Part Number	Socket With Sleeve	Separate Sleeve	Dowel Pin	External O-Ring
	Size (mm)	mm	in	mm					
8	31.75	1.25	19.78	0.78	24W500224	24W510173	24W500226	24R501280	24R501270
10	31.75	1.25	19.78	0.78	24W500225	24W510174			
12	31.75	1.25	19.78	0.78	24W500226	24W510175			
13	31.75	1.25	19.78	0.78	24W500227	24W510176	24W520049	24R501281	24R501271
14	38.10	1.50	19.78	0.78	24W500228	24W510177			
15	38.10	1.50	25.15	0.99	24W500229	24W510178			
16	38.10	1.50	25.15	0.99	24W500230	24W510179	24W520050	24R501284	24R501272
17	38.10	1.50	25.15	0.99	24W500231	24W510180			
18	38.10	1.50	28.35	1.12	24W500232	24W510181			
19	38.10	1.50	28.35	1.12	24W500233	24W510182			

1/2" Drive	Length		Diameter		Part Number	Socket With Sleeve	Separate Sleeve	Dowel Pin	External O-Ring
	Size (mm)	mm	in	mm					
13	38.10	1.50	25.15	0.99	24W500234	24W510183	24W520051	24R501283	24R501271
14	38.10	1.50	25.15	0.99	24W500235	24W510184			
15	38.10	1.50	25.15	0.99	24W500236	24W510185			
16	38.10	1.50	25.15	0.99	24W500237	24W510186	24W520052	24R501279	24R501276
17	41.15	1.62	28.35	1.12	24W500238	24W510187			
18	41.15	1.62	28.35	1.12	24W500239	24W510188			
19	41.15	1.62	28.35	1.12	24W500240	24W510189	24W520053	24R501285	24R501272
20	41.15	1.62	32.97	1.30	24W500241	24W510190			
21	41.15	1.62	32.97	1.30	24W500242	24W510191			
22	41.15	1.62	32.97	1.30	24W500243	24W510192			



eCoDrive™ Hex, Magnetic Sidewall
6-Point Sockets for Pulse Tools

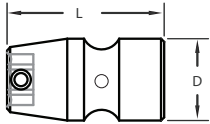
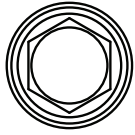

3/8" Drive	Length		Diameter		Part Number	Socket With Sleeve	Separate Sleeve	Dowel Pin	External O-Ring
	mm	in	mm	in					
8	37.85	1.49	19.78	0.78	24W500188	24W510137	24W520003	24R501280	24R501270
10	37.85	1.49	19.78	0.78	24W500189	24W510138			
12	37.85	1.49	19.78	0.78	24W500190	24W510139			
13	37.85	1.49	19.78	0.78	24W500191	24W510140			
14	37.85	1.49	19.78	0.78	24W500192	24W510141			
15	46.74	1.84	25.15	0.99	24W500193	24W510142	24W520004	24R501281	24R501271
16	46.74	1.84	25.15	0.99	24W500194	24W510143			
17	46.74	1.84	25.15	0.99	24W500195	24W510144			
18	46.74	1.84	28.35	1.12	24W500196	24W510145	24W520005	24R501284	24R501272
19	46.74	1.84	28.35	1.12	24W500197	24W510146			

3/8" Drive	Length		Diameter		Part Number	Socket With Sleeve	Separate Sleeve	Dowel Pin	External O-Ring
	mm	in	mm	in					
3/8	37.85	1.49	19.78	0.78	24W500274	Contact Us	24W520003	24R501280	24R501270
7/16	37.85	1.49	19.78	0.78	24W500277	Contact Us			
1/2	37.85	1.49	19.78	0.78	24W500280	Contact Us			
9/16	37.85	1.49	19.78	0.78	24W500283	Contact Us			

1/2" Drive	Length		Diameter		Part Number	Socket With Sleeve	Separate Sleeve	Dowel Pin	External O-Ring
	mm	in	mm	in					
13	46.74	1.84	25.15	0.99	24W500207	24W510156	24W520019	24R501283	24R501271
14	46.74	1.84	25.15	0.99	24W500261	Contact Us			
15	46.74	1.84	25.15	0.99	24W500208	24W510157			
16	46.74	1.84	25.15	0.99	24W500209	24W510158			
17	46.74	1.84	28.35	1.12	24W500262	Contact Us	24W520020	24R501279	24R501276
18	46.74	1.84	28.35	1.12	24W500210	24W510159			
19	46.74	1.84	28.35	1.12	24W500263	Contact Us			
20	46.74	1.84	32.97	1.30	24W500211	24W510160	24W520021	24R501285	24R501272
21	46.74	1.84	32.97	1.30	24W500212	24W510161			
22	46.74	1.84	32.97	1.30	24W500213	24W510162			

1/2" Drive	Length		Diameter		Part Number	Socket With Sleeve	Separate Sleeve	Dowel Pin	External O-Ring
	mm	in	mm	in					
9/16	46.74	1.84	25.15	0.99	24W500286	Contact Us for more info	24W520019	24R501283	24R501271
5/8	46.74	1.84	25.15	0.99	24W500289				
11/16	46.74	1.84	28.35	1.12	24W500292		24W520020	24R501279	24R501276
3/4	46.74	1.84	28.35	1.12	24W500295				
13/16	46.74	1.84	32.97	1.30	24W500298		24W520021	24R501285	24R501272
7/8	46.74	1.84	32.97	1.30	24W500301				
15/16	46.74	1.84	39.37	1.55	24W500304				
1	46.74	1.84	39.37	1.55	24W500307				

eCoDrive™ Hex, Deep, Magnetic Sidewall 6-Point Sockets for Pulse Tools

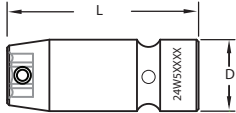
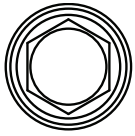

3/8" Drive	Length		Diameter		Part Number	Socket With Sleeve	Separate Sleeve	Dowel Pin	External O-Ring
	Size (mm)	mm	in	mm					
8	59.44	2.34	19.81	0.78	24W500198	24W510147	24W520006	24R501280	24R501270
10	59.44	2.34	19.81	0.78	24W500199	24W510148			
12	59.44	2.34	19.81	0.78	24W500200	24W510149			
13	59.44	2.34	19.81	0.78	24W500201	24W510150			
14	68.58	2.70	25.15	0.99	24W500202	24W510151	24W520007	24R501281	24R501271
15	68.58	2.70	25.15	0.99	24W500260	Contact Us			
16	68.58	2.70	25.15	0.99	24W500203	24W510152			
17	68.58	2.70	25.15	0.99	24W500204	24W510153			
18	74.17	2.92	28.35	1.12	24W500205	24W510154	24W520008	24R501284	24R501272
19	74.17	2.92	28.35	1.12	24W500206	24W510155			

1/2" Drive	Length		Diameter		Part Number	Socket With Sleeve	Separate Sleeve	Dowel Pin	External O-Ring
	Size (mm)	mm	in	mm					
13	68.58	2.70	25.15	0.99	24W500214	24W510163	24W520022	24R501283	24R501271
14	68.58	2.70	25.15	0.99	24W500215	24W510164			
15	68.58	2.70	25.15	0.99	24W500216	24W510165			
16	68.58	2.70	25.15	0.99	24W500217	24W510166			
17	74.17	2.92	28.35	1.12	24W500218	24W510167	24W520023	24R501279	24R501276
18	74.17	2.92	28.35	1.12	24W500219	24W510168			
19	74.17	2.92	28.35	1.12	24W500220	24W510169			
20	82.55	3.25	32.97	1.30	24W500221	24W510170			
21	82.55	3.25	32.97	1.30	24W500222	24W510171	24W520024	24R501285	24R501272
22	82.55	3.25	32.97	1.30	24W500223	24W510172			



eCoDrive™ 12-Point, Deep, Sliding Magnet, Sockets for Pulse Tools

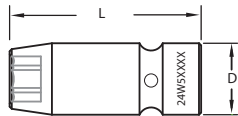
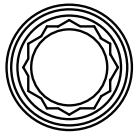

3/8" Drive	Length		Diameter		Part Number	Socket With Sleeve	Separate Sleeve	Dowel Pin	External O-Ring
	Size (mm)	mm	in	mm					
8	59.44	2.34	19.81	0.78	24W500380	Contact Us for more info	24W520006	24R501280	24R501270
10	59.44	2.34	19.81	0.78	24W500381				
12	59.44	2.34	19.81	0.78	24W500382				
13	59.44	2.34	19.81	0.78	24W500385		24W520007	24R501281	24R501271
14	68.58	2.70	25.15	0.99	24W500398				
15	68.58	2.70	25.15	0.99	24W500399				
16	68.58	2.70	25.15	0.99	24W500390		24W520008	24R501284	24R501272
17	68.58	2.70	25.15	0.99	24W500391				
18	74.17	2.92	28.35	1.12	24W500392				
19	74.17	2.92	28.35	1.12	24W500393				

1/2" Drive	Length		Diameter		Part Number	Socket With Sleeve	Separate Sleeve	Dowel Pin	External O-Ring
	Size (mm)	mm	in	mm					
13	68.58	2.70	25.15	0.99	24W500259	Contact Us for more info	24W520022	24R501283	24R501271
14	68.58	2.70	25.15	0.99	24W500394				
15	68.58	2.70	25.15	0.99	24W500395				
16	68.58	2.70	25.15	0.99	24W500396		24W520023	24R501279	24R501276
17	74.17	2.92	28.35	1.12	24W500397				
18	74.17	2.92	28.35	1.12	24W500400				
19	74.17	2.92	28.35	1.12	24W500401		24W520024	24R501285	24R501272
20	82.55	3.25	32.97	1.30	24W500402				
21	82.55	3.25	32.97	1.30	24W500403				
22	82.55	3.25	32.97	1.30	24W500404				

eCoDrive™ 12-Point, Deep, Sliding Magnet, Sockets for Pulse Tools

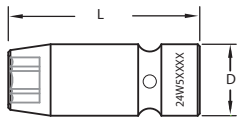
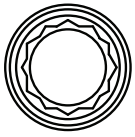

3/8" Drive	Length		Diameter		Part Number	Socket With Sleeve	Separate Sleeve	Dowel Pin	External O-Ring
	mm	in	mm	in					
8	59.44	2.34	19.81	0.78	24W500380	Contact Us for more info	24W520006	24R501280	24R501270
10	59.44	2.34	19.81	0.78	24W500381				
12	59.44	2.34	19.81	0.78	24W500382				
13	59.44	2.34	19.81	0.78	24W500385		24W520007	24R501281	24R501271
14	68.58	2.70	25.15	0.99	24W500398				
15	68.58	2.70	25.15	0.99	24W500399				
16	68.58	2.70	25.15	0.99	24W500390		24W520008	24R501284	24R501272
17	68.58	2.70	25.15	0.99	24W500391				
18	74.17	2.92	28.35	1.12	24W500392				
19	74.17	2.92	28.35	1.12	24W500393				

1/2" Drive	Length		Diameter		Part Number	Socket With Sleeve	Separate Sleeve	Dowel Pin	External O-Ring
	mm	in	mm	in					
13	68.58	2.70	25.15	0.99	24W500259	Contact Us for more info	24W520022	24R501283	24R501271
14	68.58	2.70	25.15	0.99	24W500394				
15	68.58	2.70	25.15	0.99	24W500395				
16	68.58	2.70	25.15	0.99	24W500396		24W520023	24R501279	24R501276
17	74.17	2.92	28.35	1.12	24W500397				
18	74.17	2.92	28.35	1.12	24W500400				
19	74.17	2.92	28.35	1.12	24W500401		24W520024	24R501285	24R501272
20	82.55	3.25	32.97	1.30	24W500402				
21	82.55	3.25	32.97	1.30	24W500403				
22	82.55	3.25	32.97	1.30	24W500404				

Special Socket 15mm Bolt Clearance, Magnetic

3/8" Drive Size (mm)	Length		Diameter		Part Number	Socket With Sleeve	Separate Sleeve	Dowel Pin	External O-Ring
	mm	in	mm	in					
13	30.226	1.19	19.7866	0.779	24W500333	24W510198	24W520040	24R501280	24R501270

Hex Euro Quick Change

3/8" Drive Size (in)	Length		Diameter		Part Number	With Sleeve	Separate Sleeve	Dowel Pin	External O-Ring
	mm	in	mm	in					
1/4	32.766	1.29	21.209	0.835	24W500323	24W510193	24W520002	24R501282	24R501274
7/16	32.766	1.29	21.209	0.835	24W500258	Contact Us			

1/2" Drive Size (in)	Length		Diameter		Part Number	With Sleeve	Separate Sleeve	Dowel Pin	External O-Ring
	mm	in	mm	in					
7/16	39.116	1.54	25.146	0.99	24W500324	24W510194	24W520018	24R501283	24R501271

Hex Asian Quick Change

3/8" Drive Size (in)	Length		Diameter		Part Number	With Sleeve	Separate Sleeve	Dowel Pin	External O-Ring
	mm	in	mm	in					
1/4	45.466	1.79	21.209	0.835	24W500329	24W510195	24W520002	24R501282	24R501274
7/16	45.466	1.79	21.209	0.835	24W500331	24W510197			

3/8" Drive Size (in)	Length		Diameter		Part Number	Socket With Sleeve	Separate Sleeve	Dowel Pin	External O-Ring
	mm	in	mm	in					
1/4	39.116	1.54	25.146	0.99	24W500257	Contact Us	24W520018	24R501283	24R501271
7/16	39.116	1.54	25.146	0.99	24W500330	24W510196			
5/8	39.116	1.54	25.146	0.99	24W500256	Contact Us			

Asian Extension

3/8" Drive Size (in)	Length		Diameter		Part Number	Extension With Sleeve	Separate Sleeve	Dowel Pin	External O-Ring
	mm	in	mm	in					
2	42.164	1.66	21.209	0.835	24W500006	24W510003	24W520001	24R501282	24R501274
4	100.584	3.96	21.209	0.835	24W500010	24W510007			
6	151.384	5.96	21.209	0.835	24W500039	24W510036			
8	202.184	7.96	21.209	0.835	24W500011	24W510008			
10	252.984	9.96	21.209	0.835	24W500035	24W510032			
12	303.784	11.96	21.209	0.835	24W500036	24W510033			
16	430.784	16.96	21.209	0.835	24W500012	24W510009			

Asian Extension

1/2" sq. Size (in)	Length		Diameter		Part Number	Extension With Sleeve	Separate Sleeve	Dowel Pin	External O-Ring
	mm	in	mm	in					
2	50.8	2	25.146	0.99	24W500019	24W510016	24W520017	24R501283	24R501271
4	100.33	3.95	25.146	0.99	24W500013	24W510010			
8	201.93	7.95	25.146	0.99	24W500014	24W510011			
10	252.73	9.95	25.146	0.99	24W500037	24W510034			
12	303.53	11.95	25.146	0.99	24W500038	24W510035			
16	405.13	15.95	25.146	0.99	24W500015	24W510012			

Asian Extension / Adapter

3/8" Female
x 1/4" Male

3/8"x 1/4"	Length		Diameter		Part Number	Extension With Sleeve	Separate Sleeve	Dowel Pin	External O-Ring
	mm	in	mm	in					
4	101.6	4	21.209	0.835	24W500364	Contact Us	24W520001	24R501282	24R501274

3/8" Female
x 1/2" Male

3/8"x 1/2"	Length		Diameter		Part Number	Extension With Sleeve	Separate Sleeve	Dowel Pin	External O-Ring
	mm	in	mm	in					
2	48.514	1.91	25.146	0.99	24W500375	Contact Us	24W520001	24R501282	24R501274
4	106.426	4.19	25.146	0.99	24W500376				

1/2" Female
x 3/8" Male

1/2"x 3/8"	Length		Diameter		Part Number	Extension With Sleeve	Separate Sleeve	Dowel Pin	External O-Ring
	mm	in	mm	in					
2	48.514	1.91	25.146	0.99	24W500049	Contact Us for more info	24W520017	24R501283	24R501271
4	106.426	4.19	25.146	0.99	24W500050				
8	208.026	8.19	25.146	0.99	24W500051				

Euro to Asian Extension / Adapter

3/8"	Length		Diameter		Part Number	Extension With Sleeve	Separate Sleeve	Dowel Pin	External O-Ring
	mm	in	mm	in					
2	43.18	1.7	21.209	0.835	24W500001	Contact Us	24W520001	24R501282	24R501274
4	101.6	4.00	21.209	0.835	24W500007	24W510004			
8	203.2	8.00	21.209	0.835	24W500008	24W510005			
16	406.4	16.00	21.209	0.835	24W500009	24W510006			

1/2"	Length		Diameter		Part Number	Extension With Sleeve	Separate Sleeve	Dowel Pin	External O-Ring
	mm	in	mm	in					
2	51.816	2.04	25.146	0.99	24W500002	Contact Us	24W520017	24R501283	24R501271
4	101.6	4.00	25.146	0.99	24W500016	24W510013			
8	203.2	8.00	25.146	0.99	24W500017	24W510014			
16	406.4	16.00	25.146	0.99	24W500018	24W510015			

3/4"	Length		Diameter		Part Number	Extension With Sleeve	Separate Sleeve	Dowel Pin	External O-Ring
	mm	in	mm	in					
2	51.816	2.04	29.718	1.17	24W500003	Contact Us			

Euro to Asian Extension / Adapter

1/2" Female
x 3/8" Male

1/2"x 3/8"	Length		Diameter		Part Number	Extension With Sleeve	Separate Sleeve	Dowel Pin	External O-Ring
	Size (in)	mm	in	mm					
2	48.514	1.91	25.146	0.99	24W500049	Contact Us for more info	24W520017	24R501283	24R501271
4	106.426	4.19	25.146	0.99	24W500050				
8	208.026	8.19	25.146	0.99	24W500051				

Standard Female to eCoDrive Male Adapter / Extension

3/8" sq.	Length		Diameter		Part Number	Extension With Sleeve	Separate Sleeve	Dowel Pin	External O-Ring
	Size (in)	mm	in	mm					
2	43.18	1.70	21.209	0.835	24W500024	24W510021	24W520035	24R501282	24R501270
4	101.60	4.00	21.209	0.835	24W500025	24W510022			
8	203.20	8.00	21.209	0.835	24W500031	24W510028			
16	406.40	16.00	21.209	0.835	24W500032	24W510029			

1/2"	Length		Diameter		Part Number	Extension With Sleeve	Separate Sleeve	Dowel Pin	External O-Ring
	Size (in)	mm	in	mm					
2	52.324	2.06	25.146	0.99	24W500026	24W510023	24W520036	24R501283	24R501271
4	101.6	4.00	25.146	0.99	24W500027	24W510024			
8	203.2	8.00	25.146	0.99	24W500033	24W510030			
16	406.4	16.00	25.146	0.99	24W500034	24W510031			

Asian Tube Extension

3/8" Drive	Length		Diameter		Part Number	Extension With Sleeve	Separate Sleeve	Dowel Pin	External O-Ring
	Size (in)	mm	in	mm					
8	156.972	6.18	25.4	1	24W500042	Contact Us	24W20002	24R501282	24R501274
16	360.172	14.18	25.4	1	24W500043				

1/2" Drive	Length		Diameter		Part Number	Extension With Sleeve	Separate Sleeve	Dowel Pin	External O-Ring
	Size (in)	mm	in	mm					
8	144.78	5.70	30.226	1.19	24W500044	Contact Us	24W520017	24R501283	24R501271
16	347.98	13.70	30.226	1.19	24W500045				

E - Type Torx Sockets

3/8" Drive	Length		Diameter		Part Number	Socket With Sleeve	Separate Sleeve	Dowel Pin	External O-Ring
	Size - E	mm	in	mm					
5	39.116	1.54	19.7866	0.779	24W500078	24W510056	24W520003	24R501280	24R501270
6	39.116	1.54	19.7866	0.779	24W500077	24W510055			
7	39.116	1.54	19.7866	0.779	24W500076	24W510054			
8	39.116	1.54	19.7866	0.779	24W500075	24W510053			
10	39.116	1.54	19.7866	0.779	24W500074	24W510052			
12	39.116	1.54	19.7866	0.779	24W500073	24W510051			
14	39.116	1.54	19.7866	0.779	24W500072	24W510050			
16	39.116	1.54	19.7866	0.779	24W500071	24W510049			

Magnetic

3/8" Drive	Length		Diameter		Part Number	Socket With Sleeve	Separate Sleeve	Dowel Pin	External O-Ring
	Size - E	mm	in	mm					
8	51.816	2.04	19.7866	0.779	24W500079	24W510057	24W520044	24R501280	24R501270

1/2" Drive	Length		Diameter		Part Number	Socket With Sleeve	Separate Sleeve	Dowel Pin	External O-Ring
	Size - E	mm	in	mm					
18	48.006	1.89	25.146	0.99	24W500070	24W510048	24W520019	24R501283	24R501271
20	48.006	1.89	25.146	0.99	24W500069	24W510047			

T - Type Torx Sockets

3/8" Drive	Length		Diameter		Part Number	Socket With Sleeve	Separate Sleeve	Dowel Pin	External O-Ring
	Size - T	mm	in	mm					
40	39.116	1.54	19.7866	0.779	24W500361	Contact Us	24W520003	24R501280	24R501270
55	39.116	1.54	19.7866	0.779	24W500356				

1/2" Drive	Length		Diameter		Part Number	Socket With Sleeve	Separate Sleeve	Dowel Pin	External O-Ring
	Size - T	mm	in	mm					
25	48.006	1.89	25.146	0.99	24W500357	Contact Us	24W520019	24R501283	24R501271
27	48.006	1.89	25.146	0.99	24W500358				

Torx Bit Driver Socket

3/8" Drive	Length		Diameter		Part Number	Socket With Sleeve	Separate Sleeve	Dowel Pin	External O-Ring
	Size - T	mm	in	mm					
50	30.3784	1.20	9.144	0.36	24W500067	24W510045	24W520043	24R501280	24R501270

1/2" Drive	Length		Diameter		Part Number	Socket With Sleeve	Separate Sleeve	Dowel Pin	External O-Ring
	Size - T	mm	in	mm					
50	35.2298	1.39	25.146	0.99	24W500080	Contact Us	24W520072	24R501283	24R501271

Hex Bit Holder

3/8" Drive	Length		Diameter		Part Number	Socket With Sleeve	Separate Sleeve	Dowel Pin	External O-Ring
	Size (in)	mm	in	mm					
1/4	63.5	2.50	14.2748	0.562	24W500061	24W510039	24W520039	24R501280	24R501270
5/16	63.5	2.50	14.2748	0.562	24W500060	24W510038			
7/16	63.5	2.50	19.7866	0.779	24W500063	24W510041			

1/2" Drive	Length		Diameter		Part Number	Socket With Sleeve	Separate Sleeve	Dowel Pin	External O-Ring
	Size (in)	mm	in	mm					
5/16	34.925	1.38	25.146	0.99	24W500062	24W510040	24W520038	24R501283	24R501271
7/16	34.925	1.38	25.146	0.99	24W500064	Contact rep			

Hex Bit Holder, Stainless Steel, Magnetic

3/8" Drive	Length		Diameter		Part Number	Socket With Sleeve	Separate Sleeve	Dowel Pin	External O-Ring
	Size (in)	mm	in	mm					
1/4	28.575	1.13	19.7866	0.779	24W500066	24W510044	24W520074	24R501280	24R501270
5/16	28.575	1.13	19.7866	0.779	24W500059	Contact rep			

1/2" Drive	Length		Diameter		Part Number	Socket With Sleeve	Separate Sleeve	Dowel Pin	External O-Ring
	Size (in)	mm	in	mm					
5/16	85.09	3.35	25.146	0.99	24W500065	Contact rep	24W520069	24R501283	24R501271

Hex Nutsetter, Sliding Magnet

1/4" Drive	Length		Diameter		Part Number	Socket With Sleeve	Separate Sleeve
	Size (mm)	mm	in	mm			
8	152.4	6.00	12.2682	0.483	24W500334	24W510199	24W520042
10	152.4	6.00	14.3002	0.563	24W500269	Contact your STANLEY rep	
10	304.8	12.00	14.3002	0.563	24W500270		

Hex Power Bit

1/4" Hex Drive

1/4" Drive	Part Number
Size - T	
10	24W500316
15	24W500317
20	24W500318
25	24W500319
27	24W500320
30	24W500321

Taper-Lok™ Impact Sockets

These sockets are used on the PSI Twin Hammer and Pin Clutch tools. STANLEY Assembly Technologies' Taper-Lok™ ergonomic sockets will greatly improve productivity by increasing torque accuracy, operator comfort, and reduce torque loss.

A taper inside the drive end of Taper-Lok™ sockets creates a fit that is perfectly snug with the tapered output of the impact tool anvil. This controlled alignment eliminates the vibration and rattle normally created by the loose fit and wobble of standard impact tool sockets. No vibration or wobble means a higher capability as more torque is delivered consistently to the fastener with reduced operator fatigue and injury.

3/8" DRIVE

Taper-Lok™ 3/8" Drive, Fast-Lead, 6-point, Hex

Metric Size (mm)	Length		Diameter		Part Number	Dowel Pin	External O-Ring
	mm	in	mm	in			
8	41.402	1.63	18.796	0.74	24W500454	24R501280	24R501270
10	41.402	1.63			24W500455		
12	41.402	1.63			24W500456		
13	44.958	1.77			24W500457		
14	44.958	1.77			24W500458		
15	50.546	1.99			24W500459		
16	50.546	1.99			24W500460		
17	50.546	1.99			24W500461		
18	58.42	2.3			24W500462		
19	58.42	2.3			24W500463		

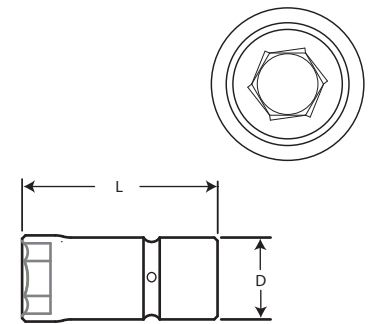

3/8" Impact Socket Set	Part No.
3/8" Drive, Taper-Lok™, Metric, Impact Socket-Set Contains 1-each of the sockets listed on the left	24W500453

SAE Standard Size (in)	Length		Diameter		Part Number	Dowel Pin	External O-Ring
	mm	in	mm	in			
1/4	41.402	1.63	18.796	0.74	24W500476	24R501280	24R501270
5/16	41.402	1.63			24W500477		
11/32	41.402	1.63			24W500478		
3/8	44.958	1.77			24W500479		
7/16	44.958	1.77			24W500480		
1/2	50.546	1.99			24W500481		
9/16	50.546	1.99			24W500482		
5/8	50.546	1.99			24W500483		
11/16	50.546	1.99			24W500484		
3/4	58.42	2.3			24W500485		
13/16	58.42	2.3			24W500486		
7/8	58.42	2.3			24W500487		

3/8" Impact Socket Set	Part No.
3/8" Drive, Taper-Lok™, SAE, Impact Socket-Set Contains 1-each of the sockets listed on the left	24W500475

Taper-Lok™ 1/2" Drive, Fast-Lead, 6-point, Hex

Metric Size (mm)	Length		Diameter		Part Number	Dowel Pin	External O-Ring
	mm	in	mm	in			
13	44.958	1.77	25.1968	0.992	24W500465	24R501279	24R501271
14	44.958	1.77			24W500466		
15	50.546	1.99			24W500467		
16	50.546	1.99			24W500468		
17	50.546	1.99			24W500469		
18	59.944	2.36			24W500470		
19	59.944	2.36			24W500471		
20	68.326	2.69			24W500472		
21	68.326	2.69			24W500473		
22	68.326	2.69			24W500474		

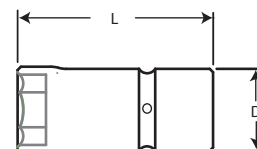
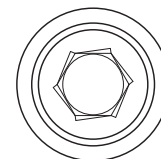

1/2" Impact Socket Set	Part No.
1/2" Drive, Taper-Lok™, Metric, Impact Socket-Set Contains 1-each of the sockets listed on the left	24W500464

SAE Standard Size (mm)	Length		Diameter		Part Number	Dowel Pin	External O-Ring
	mm	in	mm	in			
7/16	58.42	2.3	18.796	0.74	24W500489	24R501365	24R501379
1/2	58.42	2.3			24W500490		
9/16	58.42	2.3			24W500491		
5/8	58.42	2.3			24W500492		
11/16	58.42	2.3			24W500493		
3/4	69.088	2.72			24W500494		
13/16	69.088	2.72			24W500495		
7/8	69.088	2.72			24W500496		
15/16	82.296	3.24			24W500497		
1	82.296	3.24			24W500498		
1 1/16	82.296	3.24			24W500499		
1 1/8	82.296	3.24			24W500500		
1 1/4	98.298	3.87			24W500501		
1 5/16	98.298	3.87			24W500502		
1 3/8	98.298	3.87			24W500503		

1/2" Impact Socket Set	Part No.
1/2" Drive, Taper-Lok™, SAE, Impact Socket-Set Contains 1-each of the sockets listed on the left	24W500488

Taper-Lok™ 3/4" Drive, Fast-Lead, 6-point, Hex

Metric	Length		Diameter		Part Number	Dowel Pin	External O-Ring
	mm	in	mm	in			
Size (mm)	mm	in					
20	80.264	3.16	38.1	0.992	24W500520	24R501366	24R501378
21	80.264	3.16			24W500521		
22	80.264	3.16			24W500522		
23	80.264	3.16			24W500523		
24	80.264	3.16			24W500524		
25	95.504	3.76			24W500525		
26	95.504	3.76			24W500526		
27	95.504	3.76			24W500527		
29	103.378	4.07			24W500528		
30	103.378	4.07			24W500529		
32	103.378	4.07			24W500530		
35	115.57	4.55	50.8	2	24W500531	24R501367	24R501380
36	115.57	4.55			24W500532		

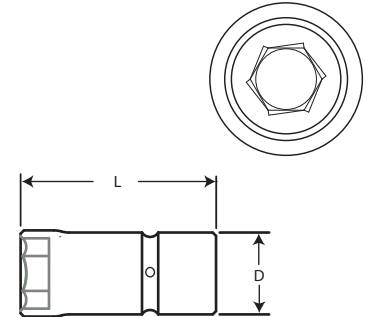

3/4" Impact Socket Set	Part No.
1/2" Drive, Taper-Lok™, Metric, Impact Socket-Set Contains 1-each of the sockets listed on the left	24W500519

SAE Standard	Length		Diameter		Part Number	Dowel Pin	External O-Ring				
	mm	in	mm	in							
Size (in)	mm	in									
3/4	80.264	3.16	38.1	1.5	24W500505	24R501366	24R501378				
13/16	80.264	3.16			24W500506						
7/8	80.264	3.16			24W500507						
15/16	80.264	3.16			24W500508						
1	95.504	3.76			24W500509						
1-1/16	95.504	3.76			24W500510						
1-1/8	103.378	4.07			24W500511						
1-3/16	103.378	4.07			24W500512						
1-1/4	103.378	4.07			24W500513						
1-5/16	115.57	4.55			50.8			2.00	24W500514	24R501367	24R501380
1-3/8	115.57	4.55							24W500515		
1-7/16	115.57	4.55	24W500516								
1-1/2	122.428	4.82	24W500517								
1-5/8	122.428	4.82	24W500518								

3/4" Impact Socket Set	Part No.
3/4" Drive, Taper-Lok™, SAE, Impact Socket-Set Contains 1-each of the sockets listed on the left	24W500504

A new part number system for standard crowfoot and tubenut sockets enables customers to describe and price standard sockets for each application. The part number includes information on head number of the tool, socket type, socket size and extension length. For special sockets or dimensions not included on this page, check the following pages or contact your local STANLEY sales representative.

Choose Your Socket





Step 1: Select the Base Code from the Head Number table

Step 2: Add Type, Size and Extension from their tables separated by forward slashes

Note: Specify socket size no larger than Max Hex Size.

Base/ Type/ Size/ Extension

Crowfoot or Tubenut Head Number	Max Hex Size		Base Code
	Size (mm)	Size (in)	
7, 16, 299, 306, 353	19	3/4	L3258
8, 61, 106, 174, 178, 311, 420, 445	13	1/2	L3224
5, 10, 19, 31, 70, 83, 126, 406,	19	3/4	L3217
13, 228, 230, 308, 333, 394, 443	13	1/2	L3213
20	27	1 1/16	L3255
21, 98, 225, 284, 416	27	1 1/16	L3240
23, 84, 95, 135, 309, 568	18	11/16	L3209
29, 35, 121, 152, 175, 221, 234, 278, 287, 496	19	3/4	L3218
47, 170, 294	11	7/16	L3222
69, 173, 279, 301, 307, 313, 317, 327, 362, 379, 381, 385, 448, 455, 477, 487, 516, 521	13	1/2	L3201
74, 164, 261, 265, 269, 271, 273, 274, 286, 291, 312, 540	18	11/16	L3211
79, 82, 103, 167, 508,	13	1/2	L3202
99, 116, 283, 285, 296	27	1 1/16	L3267
32, 75, 91, 92, 132, 136, 137, 138, 147, 182, 184, 190, 202, 208, 209, 211, 212, 213, 266, 267, 270, 288, 300, 302, 303, 305	13	1/2	20D280700
32, 75, 91, 92, 132, 136, 137, 138, 147, 182, 184, 190, 202, 208, 209, 211, 212, 213, 266, 267, 270, 288, 300, 302, 303, 305 Thru Hex	13	1/2	L3392
160	13	1/2	L3228
200, 324, 396	19	3/4	L3220
203, 456	19	3/4	L3221
216	13	1/2	L3225
246, 297, 315,	13	9/16	L3256
252, 346, 349, 387, 358, 408, 513	13	1/2	20D280700
264, 304	24	15/16	L3259
264, 304 Thru Hex	24	15/16	L3260

Type
SH Single Hex

DH Double Hex

SD Surface Drive

FL Fast Lead

Size (mm)	Size Code
4	M4
5	M5
6	M6
7	M7
8	M8
9	M9
10	M10
11	M11
12	M12
13	M13
14	M14
15	M15
16	M16
17	M17
18	M18
19	M19
20	M20
21	M21
22	M22
23	M23
24	M24
25	M25
26	M26
27	M27

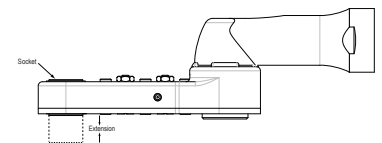
Choose mm or in	
Size (in)	Size Code
1/8	2
3/16	3
1/4	4
5/16	5
3/8	6
7/16	7
1/2	8
9/16	9
5/8	10
11/16	11
3/4	12
13/16	13
7/8	14
15/16	15
1	16
1 1/16	17

Length		Extension Code
(mm)	(in)	
Standard	Standard	0
3	1/8	3
6	1/4	6
9	3/8	9
12	1/2	12
15	5/8	15
18	3/4	18
21	7/8	21
24	1	24
27	1 1/16	27
30	1 1/8	30
33	1 1/4	33
36	1 3/8	36
39	1 1/2	39
42	1 5/8	42
45	1 3/4	45
48	1 7/8	48
51	2	51

Example Order Numbers



Example 1: A #8 crowfoot head requires a 3/8 inch surface drive socket with a 1 inch extension. Select the BASE (L3224), TYPE (SD), SIZE (6) and EXTENSION (24).

Base	Type	Size	Ext.
L3224	/SD	/6	/24

Example 2: A #147 tubenut head requires a 10mm hex socket with a standard extension. Select the BASE (L3282), TYPE (SH), SIZE (M10) and EXTENSION (0).

Base	Type	Size	Ext.
L3282	/SH	/M10	/0

Crowfoot/ Tubenut Special Socket Selection

Crowfoot Head Number(s) 8, 61, 106, 174, 178, 311, 420, 445

Use(s) Special Socket Option ~A3729.

Use the L3224 Base Socket, in the Standard Socket Configurator on Page 151, to configure a standard socket.

Hex Socket

Size	Part No.	Feature
4mm	B3434	
4mm	F3129	Blind Socket
11/32"	A3682	
7/16"	F3116	both sides have Hex
7/16"	F3674	No Chamfer
7/16"	J3724	with Lead Chamfer
1/2"	F3172	Blind Socket
13mm	J3477	Double Hex with Groove

Extended Hex Socket

Size	Extension	Part No.	Feature
7/32"(5.5mm)	3mm	20D216402	Surface Drive
7/16"	1"	J3060	Surface Drive
3/8"	3/8"	A3749	
3/8"	1/2"	A3766	
9mm	3/4"	B3515	
10mm	3mm	J3197	
10mm	4mm	J3195	
10mm	5mm	J3196	
10mm	7mm	F3802	
10mm	10mm	B3569	with Retaining Ring
10mm	19mm	B3606	
1/2"	3mm	J3229	
1/2"	1/4"	B3164	both sides have Hex
1/2"	1/2"	J3169	
13mm	1/2"	A3976	
13mm	27mm	20D216404	

Hex Magnetic Socket

Size	Part No.	Feature
7mm	J3482	
10mm	B3172	
10mm	B3543	thru-hole
3/8"	B3895	Plugged
5/16"	A3690	Plugged
5/16"	A3951	Shallow, plugged
7/16"	A3696	Plugged
7/16"	F3863	thru-hole
11mm	F3181	Shallow, plugged
1/2"	A3705	
13mm	A3923	thru-hole

Extended Hex Magnetic Socket

Size	Extension	Part No.	Feature
1/4"	7.5mm	B3344	plugged
8mm	1/4"	20D243901	
8mm	1/4"	20D216401	shallow
8mm	15mm	B3508	plugged
8mm	3/8"	F3637	
8mm	3/8"	F3652	turned down diameter
7/16"	1/2"	A3928	
7/16"	1-1/4"	20D243900	
9mm	1/4"	20D216400	
3/8"	1/4"	B3866	
10mm	2mm	A6316	
10mm	1/4"	B3850	plugged
10mm	1/2"	F3664	Fast Lead
10mm	12mm	B3181	
11mm	12mm	B3222	
11mm	1/8"	B3167	plugged
13mm	1/4"	B3776	thru-hole
13mm	1/2"	J3360	

Male Square Drive

Size	Part No.	Feature
1/4"	B3823	
5/16"	J3261	with Retaining Ring
3/8"	F3242	
1/2"	20D216403	

Torx Socket

Size	Extension	Part No.
E5		L3191
E8	6mm	F3493

Extended Hex Magnetic Socket

Size	Extension	Part No.	Feature
1/4"		F3545	Use Customer's Bit
1/4"	1/4"	20D216405	Choose bit below

~F4296 - See Bits on Page 161

Crowfoot Head Number(s) 5, 10, 19, 31, 70, 83, 126, 406

Use(s) Special Socket Option ~A4882

Use the L3217 Base Socket, in the Standard Socket Configurator on Page 151, to configure a standard socket.

Hex Socket

Size	Part No.	Feature
8mm	L4655	
1/2"	B4257	
15mm	20D270202	Special C'Bore
18mm	L4003	thru broached with stop ring
19mm	B4511	Grooved
18mm	L4672	Part broached

Extended Hex Socket

Size	Extension	Part No.	Feature
15mm	3/8"	A4933	
5/8"	1/4"	B4069	Double Hex
11/16"	1/4"	B4133	1/2" Extension on opposite side
9/16"	1/4"	B4865	
19mm	2"	F4158	
5/8"(16mm)	35mm	F4379	
3/4"	1"	F4661	Extension on both sides
15mm	1/2"	F4933	
19mm	1-1/4"	J4383	with compression ring
15mm	1/4"	L4177	Fast Leak with Retaining Ring
17mm	1/4"	L4421	Extension on both sides
15mm	3/4"	20D270201	Surface Drive

Extended Hex Magnetic Socket

Size	Extension	Part No.
15mm	1/4"	B4039
19mm	1/2"	L4788

Male Square Drive

Size	Part No.	Feature
1/2"	S7542	
5/8"	20D116800	
1/2"	A6174	Wobble Square Drive

Torx Socket

Size	Part No.
E12	L4880
E18	A6172
E20	A6405

Internal Threaded Socket

Size	Pitch	Part No.
1/2"	20	F4519
3/4"	16	20D270200

20D116801 Insert Hex Socket

Size	Part No.
21mm	20D136000

Tubenut Head Number 20

Use(s) Special Socket Option ~B4000

Use the L3255 Base Socket, in the Standard Socket Configurator on Page 151, to configure a standard socket.

Hex Socket

Size	Part No.	Feature
7/8"	L4828	Broached
11/16"	B4301	
18mm	J4153	Broached
19mm	20D281800	19mm Slot
3/4"	B4771	Broached
21mm	A6214	
22mm	20D281801	19mm Slot
15/16"	B4269	Broached
1"	F4536	Broached
1 1/16"	B4270	Broached
1 1/16"	B4505	

J4572 Special Wire Twist Socket

Extended Hex Socket

Size	Extension	Part No.	Feature
3/4"	3/4"	J4557	
3/4"	3/4"	H4601	Broached
3/4"	3"	F4945	
22mm	15mm	N4264	
24mm	15mm	J4471	Broached
1"	1"	B4502	
42mm	5.3mm	L4136	

Dual Size Hex Socket

Size 1	Size 2	Part No.	Feature
19mm	26mm	L4836	
22mm	19mm	20DS200005	

Crowfoot/ Tubenut Special Socket Selection

Crowfoot Head Number(s) 13, 228, 230, 308, 333, 394, 443

Use(s) Special Socket Option ~A4737

Use the L3213 Base Socket, in the Standard Socket Configurator on Page 151, to configure a standard socket.

Extended Hex Socket

Size	Extension	Part No.	Feature
10mm	13mm	L3344	
13mm	5mm	B4616	
13mm	1/4"	B4148	
13mm	1/4"	F4486	3/8" Broach
13mm	10mm	B4577	
13mm	1/2"	B4196	
13mm	15mm	20D124102	
13mm	3/4"	J4903	
13mm	55mm	N4499	Surface Drive
1/2"	1/4"	B4383	
1/2"	3/8"	B4463	

Hex Socket

Size	Part No.	Feature
7mm	L3404	Triple Square
5/16"	J4561	With Groove
7/16"	20D124103	Without Ring Groove
7/16"	F4277	With Ball
1/2"	L4125	
1/2"	F4140	With Groove
13mm	J3477	Double Hex with Groove

Extended Hex Magnetic Socket

Size	Extension	Part No.
10mm	1/2"	L4636
10mm	15mm	20D124100
13mm	Standard	F4354
13mm	1/4"	L4805

Hex Magnetic Socket

Size	Part No.	Feature
10mm	20D124101	
13mm	N4941	
13mm	N4939	Double Hex

Male Square Drive

Size	Part No.	Feature
3/8"	J4312	
3/8"	L4612	Paint Marker Socket

Torx Socket

Size	Part No.
E10	20D241400
E12	H4896

Internal Threaded Socket

Size	Pitch	Part No.
1/2"	20	F4363

Crowfoot Head Number(s) 21, 98, 225, 284, 416

Use(s) Special Socket Option ~A4949

Use the L3240 Base Socket, in the Standard Socket Configurator on Page 151, to configure a standard socket.

Hex Socket

Size	Part No.	Feature
12mm	N4984	
15mm	N4761	
21mm	H4478	
21mm	N4227	Broached
30mm	L4889	
1 1/4"	L4302	Broached

Male Square Drive

Size	Part No.	Feature
1/2"	N4629	
5/8"	S9143	Wobble

Extended Hex Socket

Size	Extension	Part No.	Feature
19mm	3/8"	J4823	Surface Drive
19mm	1 1/4"	A6308	
22mm	54mm	B4923	
22mm	57mm	A6477	
22mm	2 1/8"	S7502	
23mm	1"	B4455	Extension is on both sides
24mm	3/4"	F4937	Fast Lead
1"	3/4"	B4963	
1 1/8"	2"	J4856	1/2" Below Through

Torx Socket

Size	Extension	Part No.
E18	15mm	20D245800
E20		H4818

Tubenut Head Number(s) 23, 84, 95, 135, 309

Use(s) Special Socket Option ~A4929

Use the L3209 Base Socket, in the Standard Socket Configurator on Page 151, to configure a standard socket.

Hex Socket

Size	Part No.	Feature
5/16"	J4721	Broached
9/16"	H4160	
1/2"	H4256	
15mm	N4962	
17mm	F4325	Broached
18mm	N4376	Broached

Extended Hex Socket

Size	Extension	Part No.	Feature
5/8"	3/4"	J4645	
15mm	1/2"	F3303	Broached
15mm	1 3/4"	L4263	
16mm	1/2"	B4569	Broached
17mm	37mm	N4297	
18mm	1/2"	B4570	Broached

Male Square Drive

Size	Part No.	Feature
20mm	B3372	Both sides have male hex drive
20mm	B3726	

Crowfoot Head Number(s) 29, 35, 121, 152, 175, 221, 234, 278, 287, 496

Use(s) Special Socket Option ~B4105

Use the L3218 Base Socket, in the Standard Socket Configurator on Page 151, to configure a standard socket.

Hex Socket

Size	Part No.	Feature
1/4"	J4073	With Retaining Ring
5/16"	20D122602	With Retaining Ring
1/2"	F4863	
1/2"	F4408	With Ring Groove
1/2"	J4423	Double Hex
16mm	F4333	With Ring Groove
17mm	B4994	

Hex Magnetic Socket

Size	Part No.	Feature
10mm	20D122600	
13mm	A6100	
13mm	N4846	
13mm	H4167	
15mm	A6232	With Groove

Extended Hex Socket

Size	Extension	Part No.	Feature
1/4"	3/16"	F4875	With Groove
5/16"	5/8"	L4756	
13mm	13mm	20D238907	Special Outside Diameter
1/2"	3/4"	H4100	
14mm	1/4"	A6001	Extension is on both sides
9/16"	1/4"	B4185	
9/16"	5/16"	L4522	Fast Lead
9/16"	3/4"	A6412	
15mm	1/8"	F4941	
15mm	3/8"	B4754	
15mm	1/2"	L4620	1/2" Deep
15mm	85mm	A6224	
16mm	1/2"	L4014	
17mm	10mm	A6298	
18mm	1 3/4"	H4726	
18mm	2 1/4"	H4717	

Extended Hex Magnetic Socket

Size	Extension	Part No.	Feature
10mm	1/4"	H4878	
12mm	8mm	J4430	
12mm	8mm	H4735	
13mm	8mm	H4254	
13mm	1/4"	H4599	
13mm	15mm	A6442	
13mm	20mm	20D122603	11mm Bore
14mm	20mm	20D122601	
15mm	3/8"	J4274	
15mm	1/2"	H4211	

Male Square Drive

Size	Part No.	Feature
1/2"	A6088	

Internal Threaded Socket

Size	Part No.	Feature
1/2"	20	A6304

Crowfoot/ Tubenut Special Socket Selection

Use this list of special sockets only if the Standard Socket Configurator doesn't have the socket you need.

Crowfoot Head Number(s) 47, 170, 294

Use(s) Special Socket Option ~B3150

Use the L3222 Base Socket, in the Standard Socket Configurator on Page 151, to configure a standard socket.

Hex Magnetic Socket

Size	Part No.	Feature
10mm	20D118100	
10mm	F3280	Double Hex
1/4"	F3521	Bit Holder

Extended Hex Magnetic Socket

Size	Extension	Part No.	Feature
10mm	10mm	F3458	Double Hex
10mm	3/16"	F3459	
10mm	11mm	J3111	Extension is on both sides
10mm	19mm	F3658	
10mm	2 1/2"	B3528	Extension is on both sides

Crowfoot Head Number(s) 69, 173, 279, 301, 307, 313, 317, 327, 362, 379, 381, 385, 448, 455, 477, 487, 516, 521

Use(s) Special Socket Option ~B4750

Use the L3201 Base Socket, in the Standard Socket Configurator on Page 151, to configure a standard socket.

Hex Socket

Size	Part No.	Feature
1/4"	A6401	With Retaining Ring
5/16"	20D242401	Double Square Socket

Hex Magnetic Socket

Size	Part No.	Feature
12mm	20D117601	Surface Drive
13mm	F4268	
13mm	20D117606	

Extended Hex Socket

Size	Extension	Part No.	Feature
5/16"	1/4"	20D117603	
10mm	10mm	20D242400	
10mm	15mm	20D117609	Surface Drive
13mm	1/8"	A6022	Oversize

Extended Hex Magnetic Socket

Size	Extension	Part No.	Feature
10mm	6mm	20D117604	
12mm	6mm	20D117605	
13mm	6mm	20D117600	
13mm	9mm	20D117602	Surface Drive
13mm	15mm	20D107900	
13mm	20mm	20D117607	Surface Drive

Male Square Drive

Size	Part No.	Feature
3/8"	H4212	

Torx Socket

Size	Extension	Part No.
E12		20D242404
E12	15mm	A6431

Miscellaneous

Part No.	Feature
20D117608	12mm Hex Insert
20D135800	16mm Magnetic Socket with 12mm Hex Drive

Tubenut Head Number(s) 74, 164, 261, 265, 269, 271, 273, 274, 286, 291, 312

Use(s) Special Socket Option ~B3251

Use the L3211 Base Socket, in the Standard Socket Configurator on Page 151, to configure a standard socket.

Hex Socket

Size	Part No.	Feature
12mm	20D243700	Broached Through
12mm	20D232900	
13mm	L3428	Surface Drive
13mm	F3277	Broached Flush
1/2"	F3092	Broached
14mm	20D243701	Broached Through
15mm	20D243704	Broached Through
16mm	A6376	Surface Drive
16mm	20D222500	Surface Drive
17mm	B3521	Broached Through
18mm	B3711	Broached Through

Extended Hex Socket

Size	Extension	Part No.	Feature
12mm	1/4"	20D230600	Extension on both sides
12mm	13mm	20D230300	Double Hex
13mm	1/4"	20D239100	
13mm	12mm	20D229200	
13mm	3/4"	20D238500	
5/8"	Standard	A6264	
9/16"	1/2"	A6265	
14mm	27mm	20D243702	Broached Through
16mm	5mm	A6271	
17mm	3mm	20D243705	6.5 Deep

Crowfoot Head Number(s) 79, 82, 103, 167, 508

Use(s) Special Socket Option ~B4953

Use the L3202 Base Socket, in the Standard Socket Configurator on Page 151, to configure a standard socket.

Hex Socket

Size	Part No.	Feature
13mm	B4984	Double Hex

Extended Hex Magnetic Socket

Size	Extension	Part No.	Feature
13mm	6mm	20D139100	Magnetic

Internal Threaded Socket

Size	Pitch	Feature
1/2"	20	20D238100

Tubenut Head Number(s) 99, 116, 283, 285, 296

Use(s) Special Socket Option ~F4591

Use the L3267 Base Socket, in the Standard Socket Configurator on Page 151, to configure a standard socket.

Hex Socket

Size	Part No.	Feature
19mm	L3099	8mm Deep
3/4"	F4621	Broached through
3/4"	L4680	Special Slot
13/16"	F4622	Broached through
21mm	20D267200	19mm Slot, 6mm Deep
22mm	H4925	Broached through
22mm	20D267204	19mm Slot
22mm	20D267202	Special Slot
7/8"	F4623	Broached through
15/16"	F4624	Broached through
24mm	J4567	22.5mm Slot
24mm	H4178	7mm Deep
1"	F4625	Broached through
1 1/16"	F4626	Broached through

Extended Hex Socket

Size	Extension	Part No.	Feature
19mm	10mm	20D246600	
20mm	3/8"	20D232800	
20mm	3/8"	20D216700	
21mm	40mm	N4702	Broached through
22mm	105mm	20D237900	
7/8"	1/4"	N4497	Double Hex
7/8"	1/2"	J4733	
7/8"	1"	N4381	
7/8"	1"	H4141	
7/8"	1 3/8"	N4363	Fast Lead
7/8"	2 5/8"	H4102	
24mm	20mm	J3896	36mm Diameter
30mm	45mm	J3895	

J4455 Special Socket For Turnbuckle

Crowfoot/ Tubenut Special Socket Selection

Tubenut Head Number(s) 147, 32, 75, 91, 92, 132, 136, 137, 138, 182, 184, 190, 202, 208, 209, 211, 212, 213, 266, 267, 270, 288, 300, 302, 303, 305

Use(s) Special Socket Option ~F3577

Use the L3281, L3282, L3283, or L3392 Base Socket, in the Standard Socket Configurator on Page 151, to configure a standard socket.

Hex Socket

Size	Part No.	Feature
8mm	J3297	
9mm	J3296	
3/8"	A6027	
10mm	F3861	
10.4mm	20D255000	
11mm	J3018	
11mm	J3362	Double Hex
7/16"	H4219	
12mm	J3486	
13mm	F3577	
13mm	A6213	Double Hex
13mm	F3689	Double Hex
13mm	F3946	Surface Drive
1/2"	H4701	

Extended Hex Socket

Size	Extension	Part No.	Feature
8mm	5mm	J3784	
3/8"	1/4"	H4718	
10mm	1/4"	J3674	
10mm	10mm	H4496	
10mm	12mm	L3312	Surface Drive
11mm	5mm	J3456	
11mm	8mm	H4530	
11mm	10mm	J3019	
11mm	10mm	L3378	Double Hex
11mm	15mm	J3361	
11mm	15mm	J3680	
7/16"	3/8"	H4440	
7/16"	15mm	H4788	
12mm	3mm	L3143	
12mm	5mm	L3109	
12mm	5mm	J3501	Double Hex
12mm	10mm	L3110	
12mm	15mm	L3111	
13mm	6mm	L3422	
13mm	6mm	L3423	Surface Drive
13mm	7mm	L3359	
13mm	3/8"	L3374	
13mm	10mm	L3411	Double Hex

Crowfoot Head Number 160

Use(s) Special Socket Option ~F3812

Use the L3228 Base Socket, in the Standard Socket Configurator on Page 151, to configure a standard socket.

Extended Hex Magnetic Socket

Size	Extension	Part No.	Feature
10mm	3/4"	J3265	

Torx Socket

Size	Extension	Part No.
E10		20D215600
E10	5mm	20D215601

Crowfoot Head Number(s) 200, 324, 396

Use(s) Special Socket Option ~N4774

Use the L3220 Base Socket, in the Standard Socket Configurator on Page 151, to configure a standard socket.

Hex Socket

Size	Part No.
15mm	N4774

Crowfoot Head Number 216

Use(s) Special Socket Option ~H4086

Use the L3225 Base Socket, in the Standard Socket Configurator on Page 151, to configure a standard socket.

Male Hex Drive

Size	Part No.	Feature
1/2"	20D248400	

Crowfoot Head Number(s) 203, 456

Use(s) Special Socket Option ~N4864

Use the L3221 Base Socket, in the Standard Socket Configurator on Page 151, to configure a standard socket.

Extended Hex Socket

Size	Extension	Part No.	Feature
13mm	Standard	20D213302	.312 Deep

Torx Magnetic Socket

Size	Part No.	Feature
T-50	20mm	20S111300

Extended Hex Magnetic Socket

Size	Extension	Part No.	Feature
10mm	Standard	20D213303	
13mm	Standard	20D213301	

Crowfoot Head Number(s) 246, 297, 315

Use(s) Special Socket Option ~H4648

Use the L3256 Base Socket, in the Standard Socket Configurator on Page 151, to configure a standard socket.

Hex Magnetic Socket

Size	Part No.	Feature
13mm	20D114700	
13mm	20D114704	5.3mm Deep

Extended Hex Socket

Size	Extension	Part No.	Feature
8mm	6mm	20D230004	Double Hex, Special O.D.
10mm	36mm	20D230001	45mm Extension on other side
12mm	6mm	20D114706	Magnetic
13mm	1/4"	20D114705	Magnetic
13mm	1/4"	H4763	Magnetic
13mm	1/4"	A6078	Magnetic
9/16"	3/8"	A6314	Double Hex

Tubenut Head Number(s) 252, 346, 349, 387, 358, 408, 513

Use(s) Special Socket Option ~L3130

Use the 20D280700, L3233 Base Socket, in the Standard Socket Configurator on Page 151, to configure a standard socket.

Hex Socket

Size	Part No.	Feature
11mm	20D245408	5.3mm Deep
13mm	20D245405	Surface Drive
13mm	20D245406	1/4" Deep, Surface Drive, Thick Wall
13mm	20D245407	1/4" Deep, Thick Wall
13mm	20S211100	1/4" Deep, Surface Drive
13mm	20S211101	1/4" Deep

Extended Hex Socket

Size	Extension	Part No.	Feature
12mm	9mm	20S213500	.312 Deep
14mm	2mm	20D245400	

Tubenut Head Number(s) 264, 304

Use(s) Special Socket Option ~F3388

Use the L3259, L3260 Base Socket, in the Standard Socket Configurator on Page 151, to configure a standard socket.

Hex Socket

Size	Part No.	Feature
15mm	L3405	
18mm	20D281200	5/16" Deep
24mm	L3347	1/2" Deep

Extended Hex Socket

Size	Extension	Part No.	Feature
13mm	Standard	L3412	
3/4"	3/4"	L3005	
13/16"	1"	F3461	
7/8"	1"	H4012	

Crowfoot/ Tubenut Special Socket Selection

Use this list of special sockets only if the Standard Socket Configurator on page 143 doesn't have the socket you need.

Crowfoot Head Number(s) 7, 16, 299, 306, 353

Use(s) Special Socket Option ~A4690.

Use the L3258 Base Socket, in the Standard Socket Configurator on Page 151, to configure a standard socket.

Hex Socket

Size	Extension	Part No.	Feature
13mm		20D111300	
5/16"		A6395	
14mm		20D118801	Drive Insert
17mm		L4049	
17mm	62mm	B4047	

Hex Bit

Size	Extension	Part No.	Feature
3/16"		A6179	
1/4"		A5668	
3/8"		A5666	
5mm		F4380	
6mm		F4399	
6mm		A6206	Square Bit
6mm	5mm	A6207	
7mm		F4296	
8mm		F4513	
10mm		L4259	
14mm		A5724	

Torx Bit

Size	Extension	Part No.
T30		A6341
T30	20mm	20D240609
T40		A6373
T45		20D240600
T45	20mm	20D240610
T50		A6403

Special Bit

Size	Extension	Part No.
XNZ		H4533
Slotted		20D246700

5/16" Bit Holder 20D118800 with Bit Retainer Clip



A new part number system for standard flush angle head sockets enables customers to describe and price standard sockets for each application. The part number includes information on head number of the tool, socket type, socket size and extension length. For special sockets or dimensions not included on this page, check the following pages of special sockets or contact your local STANLEY sales representative.

Choose Your Socket

Step 1: Select the Base Code from the Head Number table

Step 2: Add Type, Size and Extension from their tables separated by forward slashes

Note: Specify socket size no larger than Max Hex Size.

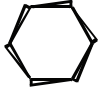
Flush Angle Head Number	Max Hex Size		Base Code	Type	Size		Extension		
	Size (mm)	Size (in)			Size (mm)	Size Code	Length (mm)	Length (in)	Extension Code
A15 (as in EB33LA15-27)	13	1/2	20D283200	SH Single Hex 	4	M4	1/8	2	Standard Standard 0
A18	16	5/8	20D213505		5	M5	3/16	3	
A19	17	5/8	20D222300		6	M6	1/4	4	3
A22	19	3/4	L3270		7	M7	5/16	5	6
A26	22	7/8	L3435	DH Double Hex 	8	M8	3/8	6	9
					9	M9	7/16	7	9
				SD Surface Drive 	10	M10	1/2	8	12
					11	M11	9/16	9	15
					12	M12	5/8	10	18
					13	M13	11/16	11	21
				FL Fast Lead 	14	M14	3/4	12	24
					15	M15	13/16	13	27
					16	M16	7/8	14	30
					17	M17	15/16	15	33
					18	M18	1	16	36
					19	M19	1 1/16	17	39
					20	M20			42
				21	M21			45	
				22	M22			48	
				23	M23			51	
				24	M24				
				25	M25				
				26	M26				
				27	M27				

Example Order Number

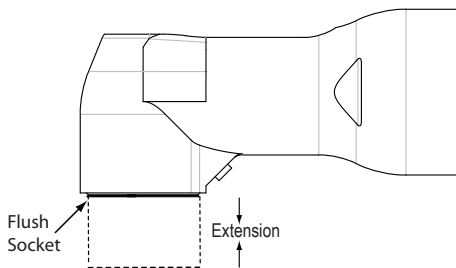

Example: An A19 flush angle head requires a 3/8 in surface drive socket with a 1 in extension. Select the BASE (20D222300), TYPE (SD), SIZE (6) and EXTENSION (24).

Write the Socket Part Number with the (/) separating each number.

Base	Type	Size	Ext.
20D222300	/SD	/6	/24

Flush Angle Special Socket Selection

Use this list of special sockets only if the Standard Socket Configurator on page 161 doesn't have the socket you need.

~B3686 Socket Options for **A13** Flush Output 20D121914

Maximum Hex size for this output is 12mm

* B3686 is the default socket unless another is specified on Purchase Order.

Hex Socket

Size	Part No.	Feature
4mm	B3834	
7mm	B3686*	
1/4"	B3751	
5/16" (8mm)	B3752	
5/16" (8mm)	20D126500	With Retaining Ring
3/8"	B3753	
10mm	B3754	

Hex Magnetic Socket

Size	Part No.
5/16" (8mm)	J3823
10mm	L3393

Double Hex Magnetic Socket

Size	Part No.
10mm	20D126503

Torx Socket

Size	Part No.
E10	20D253202

Extended Hex Magnetic Socket

Size	Extension	Part No.
5/16" (8mm)	1/2"	20D126501
10mm	1/4"	L3073

Extended Hex Socket

Size	Extension	Part No.
8mm	1/4"	J3041
5/16" (8mm)	1/16"	J3706
10mm	5mm	20D253204
10mm	10mm	20D253200
10mm	3/4"	20D238300
10mm	1/2"	J3100

Double Hex Socket

Size	Part No.
8mm	L3154
10mm	20D253205

~20D905800 Socket Options for **A14** Flush Output 20D112113

Maximum Hex size for this output is 13mm

* 20D255500 is the default socket unless another is specified on Purchase Order.

Surface Drive Socket

Size	Part No.
10mm	20D255505
12mm	20D255500*
13mm	20D255501

Surface Drive Magnetic Socket

Size	Part No.
10mm	20D126402
12mm	20D126400
13mm	20D126401

Extended Surface Drive Thin Wall Socket

Size	Extension	Part No.
13mm	1/4"	20D126406

Includes 20D236604 Compression Ring to prevent cracking

Extended Surface Drive Socket

Size	Extension	Part No.
10mm	10mm	20D255503
12mm	1/4"	20D255506
13mm	1/4"	20D255508
13mm	9mm	20D255507

Extended Surface Drive Magnetic Socket

Size	Extension	Part No.
10mm	10mm	20D126405
13mm	9mm	20D126404

~20D901200 Socket Options for **A18** Flush Output 20D136503

* F4747 is the default socket unless another is specified on Purchase Order.

Hex Socket

Size	Part No.	Feature
6mm	20D213504	
5/16"(8mm)	L4653	with Retaining Ring
3/8"	20D213501	
10mm	F4897	
7/16"	F4896	
11mm	F4898	
12mm	L4006	
1/2"	F4895	
13mm	F4899	
13mm	L4543	1/2" clearance hole
9/16"	F4747*	
14mm	20D213500	
15mm	F4900	
15mm	N4769	with Retaining Ring
5/8"(16mm)	F4894	

Extended Hex Socket

Size	Extension	Part No.	Feature
10mm	3mm	N4638	
10mm	7mm	N4251	
10mm	8mm	20D213503	
10mm	1"	J4979	
12mm	1/4"	L4839	
13mm	1/8"	N4086	
13mm	1/4"	N4918	
13mm	12mm	H4494	
13mm	1/2"	L4435	
13mm	1"	J4444	
9/16"	1/4"	J4413	
14mm	1/4"	N4268	
14mm	16mm	J4311	
15mm	1/4"	L4378	
15mm	1/4"	N4686	with Retaining Ring
15mm	3/8"	H4459	
15mm	1/2"	J4684	
15mm	1/2"	20D213502	Surface Drive
16mm	1/4"	N4312	
16mm	150mm	N4343	
17mm	5mm	H4301	
17mm	20mm	A6192	

Surface Drive Socket

Size	Part No.
13mm	L4022

Extended Surface Drive Socket

Size	Extension	Part No.
3/8"	10mm	H4236
13mm	5mm	L4935
13mm	10mm	L4934
14mm	30mm	H4371
16mm	1/4"	N4581

Hex Magnetic Socket

Size	Part No.
13mm	L4834

Extended Hex Magnetic Socket

Size	Extension	Part No.
10mm)	8mm	20D118202
11mm	5/8"	L4509
12mm	3mm	A6309
13mm	1/2"	H4921
13mm	23mm	20D118200
15mm	3/8"	A6115

Torx Socket

Size	Part No.
E8	H4367

Torx Socket

Size	Part No.
5mm	X4048
6mm	X4047
8mm	X4091
10mm	X4093
T30	X4198
T40	X4248
T50	X4249

Flush Angle Special Socket Selection

Use this list of special sockets only if the Standard Socket Configurator doesn't have the socket you need.

~20D903900 Socket Options for **A19 (Threaded)** Flush Output 20D100021 and **A19 (Splined)** Flush Output 20D100106

Use the 20D222300 Base Socket, in the Standard Socket Configurator on Page 161, to configure a standard socket.

Hex Socket

Size	Part No.
9/16"	20D222305
18mm	20D222308

Extended Hex Socket

Size	Extension	Part No.
17mm	6mm	20D118003
18mm)	12mm	20D118001

Extended Hex Magnetic Socket

Size	Extension	Part No.
18mm)	12mm	20D118002

Torx Bit

Size	Extension	Part No.
T30		A6341
T30	20mm	20D240609
T40		A6373
T45		20D240600
T45	20mm	20D240610
T50		A6403

~20D904000 Bit Options for 5/16" Bit Holder 20D118000 with Bit Retainer Clip

Choose Bit

Size	Extension	Part No.	Feature
3/16"		A6179	
1/4"		A5668	
3/8"		A5666	
5mm		F4380	
6mm		F4399	
6mm		A6206	Square Bit
6mm	5mm	A6207	
7mm		F4296	
8mm		F4513	
10mm		L4259	
14mm		A5724	

Miscellaneous Bits

Size	Extension	Part No.
XNZ		H4533
Slotted		20D246700

~20D902700 Socket Options for **A22** Flush Output 20D100309

Use the 20D115100 Base Socket, in the Standard Socket Configurator on Page 161, to configure a standard socket.

Torx Socket

Size	Part No.
E18	20D268400

~20D903700 Socket Options for **A26** Flush Output 20D100409

Use the 20D116600 Base Socket, in the Standard Socket Configurator on Page 161, to configure a standard socket.

~A5170 Socket Options for **A32** Flush Output 20D102201

Size	Part No.
17mm	20D267300
18mm	A5651
19mm	A5248
3/4" Square	A5479
21mm	A5175
22mm	A5112
22mm Fast Lead	A5183

Size	Part No.
23mm	20D267303
24mm	A5107
24mm Fast Lead	A5380
24mm Surface Drive	A5438
1"	A5113
1" Fast Lead	A5473
27mm	A5114

Size	Extension	Part No.
17mm	1/4"	20D267301
21mm	1/2"	A6234
24mm	8mm	A5261
24mm	1/2"	A6428
24mm Surface Drive	1/2"	20D267302
24mm	15mm	A5129
27mm	2.5mm	A5238
27mm	20mm	A5574

LH18 Output Options

~20D905700 Socket Options

Hex

Size	Part No.
14mm	20D253600
15mm	20D253604
16mm	20D253601
17mm	20D253603
18mm	20D253606
19mm	20D253610
24mm	20D253611

~20D905700 Tang Options

Size	Extension	Part No.
5mm	7.5mm	20D261701
6mm		20D261703
6mm	8mm	20D261700
6mm	10mm	20D2617020

~20D905600 Bit Holder Options

Size	Part No.
1/4"	20D254200
5/16"	20D253400

Extended Hex

Size	Extension	Part No.
14mm	5mm	20D253602
14mm	6mm	20D253605
16mm	17mm	20D253607

LH22 Output Options

~N4617 Socket Options

Hex

Size	Part No.
7/16"	A6184
7/8"	A6186
13mm (1/2")	A6185
14mm	H4747
9/16	N4884
15mm	N4665
16mm (5/8")	N4617
17mm	H4270
18mm	N4619
19mm	N4746
11/16"	20D235100
21mm	N4793
22mm	H4600
24mm	A6261
1"	20S202000
27mm	20D232607

Extended Hex

Size	Extension	Part No.
14mm	1-5/8"	A6451
14mm	2-5/8"	20D215100
14mm	4-5/8"	20D215101
14mm	7-3/8"	20D215102
15mm	1/2"	H4597
15mm	1"	A6282
15mm	6"	A6002
16mm	3/8"	20D245502
16mm	17mm	20D245503
16mm	30mm	N4620
16mm	60mm	20D245500
16mm	200mm	20D245501
18mm	17mm	20D253608
18mm	1"	20D227000
18mm	27mm	20D222003
18mm	3"	20D233000
19mm	11mm	20D215106
21mm	67.6mm	20D222006
21mm	110mm	20D132204
21mm	6"	20D222600
24mm	1/2"	20D222903
27mm	75mm	20D232604

Deep Extended Hex

Size	Extension	Part No.
18mm	18mm	H4038
21mm	18mm	H4037

Surface Drive Extended Hex

Size	Extension	Part No.
17mm	1-1/8"	H4651
18mm	1/2"	A6269
18mm	46mm	H4500
18mm	12-1/2"	20D132203
21mm	40mm	20D222001
21mm	80mm	20D222000

Extension Tube Options with Hex Sockets

Size	Extension	Part No.
18mm	8"	20D132201
18mm	12"	20D132200
19mm	4"	20D132202

Hex Surface Drive

Size	Part No.
13mm	H4435
15mm	A6200
17mm	N4750
18mm	H4036
21mm	H4595

Hold & Drive Socket, Bit & Tang Options

LH22 Output Options *continued*

~F4287 Tang Options

Description	Part No.
7.7MM X 9.8MM FEMALE SHANK	F4287
1/4" HEX HOLDER	F4360
10MM FEM.HEX TANG HOLDER	F4406
7.7 X 9.8 X 16MM EXT TANG HOLD	F4542
5MM X 8MM TANG HOLDER	F4544
5.7MM X 8MM TANG HOLDER	F4572
8MM (5/16) INT. HEX TANG	F4573
5.9MM X 8.1MM TANG HOLDER	F4596
10MM X 13MM TANG HOLDER	F4600
8.5 HEX FEMALE TANG HOLDER	F4636
.390" X .529" TANG HOLDER	F4673
8MM X 6.35MM TANG HOLDER	F4718
2.7MM X 7MM BIT	F4866
6.7MM X 7MM TANG HOLDER	F4870
7.2MM X 10.2MM TANG HOLDER	F4975
10MM TANG HOLD LEFT HAND	J4043
1/4 X 5/16 TANG HOLDER	J4178
8MM X 6.35 X 1/2 TANG HOLDER	J4214
8.5 X 10.5 X 16MM TANG HOLDER	J4296
8.5 X 10.5MM TANG HOLDER	J4302
9.75 X 12MM TANG HOLDER	J4314
7.7 X 9.8 X 80MM TANG HOLDER	J4315
7.7 X 9.8 X 157MM TANG HOLDER	J4317
8MM HEX TANG HOLDER 10MM EXT	J4382
8MM HEX TANG HOLDER	J4456
7MM FEMALE HEX TANG HOLDER	J4586
6.3 X 9MM TANG HOLDER	J4707
8MM X 11MM TANG HOLDER	J4785
8MM X 5.7MM X 1" EXT TANG	J4830
6.3 X 7.5MM TANG HOLDER	J4877
8.90 X 11.20MM X 80MM TANG	J4990
9MM FEMALE HEX TANG HOLDER	L4005
10MM X 6MM TANG HOLDER	L4017
5MM X 8MM TANG HOLDER	L4019
11/32 HEX FEMALE TANGE	L4106
8.2MM X 9.8MM TANG HOLDER	L4117
3/8 FEMALE HEX TANG HOLDER	L4373
9.2 X 12.5MM TANG HOLDER	L4523
8MM X 5.77MM TANG HOLDER	L4524
6MM X 7.72MM TANG HOLDER	L4544
6 X 8MM TANG HOLDER	L4644
TANG HOLDER 9MM SURF DR	L4694
TANG HOLDER 12.5 X 9.2 MM	L4738
TANG HOLDER 12.5 X 9.2 X 300MM	L4732
TANG HOLDER 8MM HEX 80 MM EXT	L4784
11MM HEX TANG HOLDER	L4803

Description	Part No.
8MM HEX TANG HOLDER X 19 MM	L4848
TANG HOLDER 8.2 X 9.8 MM	L4869
4MM MALE HEX TANG HOLDER	L4898
6.3 X 9.8MM TANG HOLDER	L4978
TANG HOLDER 12.5 X 9MM X	N4029
TANG HOLDER 12.5 X 9MM X 145MM	N4030
TANG HOLDER 12.5 X 9	N4031
TANG HOLDER 10 X 7.6MM X	N4033
TANG HOLDER 12.5 X 9MM X	N4032
10MM X 7.6MM TANG HOLDER	N4133
12.5MM X 9MM TANG HOLDER	N4130
12.5MM X9MM TANG HOLDER 27MM	N4131
12.5MM X 9MM TANG HOLDER 102MM	N4132
9.2 X 12.5MM TANG HOLDER 157MM	N4151
12.5 X 9MM TANG HOLDER 62MM	N4187
TANG HOLDER 10MM HEX X 1.531	N4189
TANG HOLDER 6MM HEX	N4192
12.5MM X 9MM TANG HOLDER	N4384
8 X 5.7 TANG HOLDER 87MM EXT	N4400
6.3 X 8.0 X 32MM EXT TANG	N4413
9.2 X 12.5MM TANG HOLDER 8.5MM	N4467
9.2MM X 12.5MM X 26.5MM EXT.	N4469
10MM HEX T HOLDER 1/4" EXT	N4575
8MM X 12MM TANG HOLDER	N4483
6MM X 13MM TANG HOLDER	N4484
7.2MM X 9.2MM TANG HOLDER 80MM	N4587
TORX SOCKET 3/8" SQ X E14	R7927
7.7MM X 9.8MM X 30MM	N4621
7.2MM X 9.2MM TANG HOLDER	N4658
10 X 7.6MM TANG HOLDER 182MM	N4697
10 X 7.6MM TANG HOLDER 102MM	N4699
8MM X 6MM TANG HOLDER	N4666
10MM X 3-1/8 EXT TANG HOLDER	N4712
6MM HEX TANG HOLDER 80MM EXT	N4716
TANG HOLDER 9 X 11.5MM X	N4747
TANG HOLDER 9 X 12.6MM X 157MM	N4748
TANG HOLDER 8 X 10MM X 80MM	N4749
TANG HOLDER 8 X 10MM X 157MM	N4752
5MM HEX TANG HOLDER	N4758
1/4" X 7/16" TANG HOLDER	N4826
6.3MM X 9.8MM TANG HOLDER 37MM	N4834
10MM X 7MM TANG HOLDER	N4921
11/32" HEX TANG HOLDER	N4927
10MM X 7.6MM TANG HOLDER	N4994
10MM X 7.3MM TANG HOLDER 152MM	N4995
14MM DOUBLE HEX SOCKET	N4064

Description	Part No.
6.3MM X 9.3MM TANG HOLDER	H4115
7MM HEX TANG HOLDER 1" EXT	H4161
8MM SQ FEMALE TANG HOLDER	H4191
8MM X 11MM TANG HOLDER W/ LEAD	H4176
6 X 10MM TANG HOLDER .600 OD	H4209
.340 HEX TANG HOLDER	H4210
8MM HEX TANG HOLDER 1" EXT	H4372
TORX SOCKET TX3114	H4373
9.2 X 12.5MM TANG HOLDER	H4448
9.2 X 12.5MM TANG HOLDER 182MM	H4483
9.22 X 12.5MM TANG HOLD	H4484
9.2 X 12.5MM TANG HOLDER	H4485
8 X 10MM TANG HOLDER 10MM EXT	H4488
6.3 X 8.7MM TANG HOLDER 80MM	H4489
4MM X 6MM TANG HOLDER	H4475
9MM HEX TANG HOLDER 46MM EXT	H4499
6 X 8MM TANG HOLDER 43MM EXT	H4577
9 X 11MM TANG HOLDER	H4578
6 X 8MM TANG HOLDER 47MM EXT	H4593
5.7 X 8MM TANG HOLDER 5MM EXT	H4606
5.6 X 9.8MM TANG HOLDER	H4607
5.9 X 6.8MM TANG HOLDER	H4676
6.8 X 8.25MM TANG HOLDER	H4725
2 STEP TANG HOLD 6.00&7.08 X	H4748
7MM X 11MM TANG HOLDER	H4761
7.3MM X 9.4MM TANG HOLDER	H4829
5.7MM X 8MM TANG HOLDER	H4840
6.35 X 8.12MM TANG HOLDER	H4858
5 X 7.5MM TANG HOLDER	H4857
12MM FEMALE HEX TANG HOLDER	H4874
10MM FAST LEAD TANG HOLDER	H4877
8MM HEX TANGHOLDER 8" EXT	H4888
TANG HOLDER 9.4 X 11.3MM STD	H4889
TANG HOLDER 9.2MMX12.5MMX45MM	H4819
8.0 X 10.5MM TANG HOLDER, 8"	H4904
8.7 X 11MM TANG OLDER, STD.	H4905
10.2 X 11.5MM TANG HOLDER, STD	H4906
TANG HOLDER 8MM X 10MM 1-1/8	H4958
10MM HEX TANG HOLD 32MM EXT	H4960
7MM FEMALE TANG HOLDER 6" EXT	A6003
4.4 X 8MM TANG HOLDER	A6005
E12 TORX SOCKET	R8461
6.24 X 7.5MM TANG HOLDER	A6136
10MM HEX X 75MM EXT TANG	A6233
8MM SQ TANG HOLDER 47MM EXT	A6226
6MM X 8MM TANG HOLDER	A6089

LH22 Output Options *continued*

~F4287 Tang Options

Description	Part No.
TANG/EXTENSION KIT,8MMHX,12"LG	20D132300
TANG HOLDER 11MM SURF. DR X	20D214300
TANG HOLDER 8MM SURF. DR. X	20D214301
TANG HOLDER 6.4MM X 8.4M X	20D215400
10MM FEMALE HEX x 6.00"	20D222700
A3H TANG HOLDER, 8.8MM X 9.8MM	20D226100
TANG HOLDER SP. 11.28 DOUBLE	20S200602
E8 TORX TANG HOLDER,	20D226200
15MM X 17MM TANG HOLDER	20S201900
TANG HOLDER 5.0 X 6.3MM	20D242700
TANG HOLDER - 7MM SURF DR	20D246900
5.5 X 7.3, 6MM EXT,TANG HOLDER	20D242701
6.0MM X 5.0 MM, TANG HOLDER	20D242702
TANG HOLDER, E12 TORX	20D226201
E8 TORX X 6" EXT HEX BIT	20D226202
6.5MM X 8MM, TAPERED LEAD,TANG	20D226101
10.22mm FEMALE HEX TANG HOLDER	20D222702
TANG HOLDER 5.4mm X 7.7mm	20D242703
H22 SKT/EXT TUBE KIT, 19mm, 4"	20D132202
8MM X 8" EXT H22 TANG ASM	20D132301
8MM X 12-1/2" EXT, SURF DR H22	20D132305
10MM X 32MM EXT, SURF DR TANG	20D245103
6MM HEX 6MM DEEP, TANG H22	20D214303
13MM HEX TANG HOLDER,A22/40A4H	20D214304
7.2MM X 10MM, 11MM EXT TANG	20D214305
10MM X 37MM,SURF DR, TANG HLDR	20D245105
10MM X 37MM EXT.,TANG HOLDER	20D245106
10MM X 67.6MM EXT, HEX,TANG	20D245109
10MM X 55MM OAL TANG H22/H26	20D245112
10mm HEX, 64mm O'ALL LENGTH	20D245111

~F4288 Bit Holder Options

Size	Extension	Part No.
1/4"		F4360
1/4"		20D215200
1/4"	1/4"	A6181
1/4"	1/4"	A6182
1/4"	1 5/8"	A6452
5/16"		F4288
5/16"		A6193
5/16"		S7750 (Special Diameter)
5/16"	1/4"	A6183
5/16"	31mm	N4631
5/16"	1"	20D226900
5/16"	60mm	H4897
5/16"	3"	20D233100
5/16"	80mm	N4670
5/16"	100mm	20DS200009
5/16"	110mm	20D132306
5/16"	4"	20D132302
5/16"	150mm	20D215208
5/16"	155mm	20D215207
5/16"	175mm	20D247200
5/16"	6 5/8"	20D215202
7/16"		20D215201

Hold & Drive Socket, Bit & Tang Options

LH26 Output Options

~N4285 Socket Options

Description	Part No.
10MM SURFACE DR SOCKET	A6137
17MM HEX SOCKET	F4285
19MM HEX SOCKET	F4294
14MM SOCKET	F4359
21MM SOCKET	F4401
22MM HEX SOCKET	F4487
24MM (15/16") HEX SOCKET	F4512
19MM X 16MM EXT SOCKET	F4541
9/16" HEX SOCKET	F4571
18MM HEX SOCKET	F4635
19MM X 10MM HEX SOCKET	F4653
15MM HEX SOCKET	F4717
1-1/16HEX (27MM) SOCKET	F4867
19MM X 7MM SURFACE DR. SOCKET	F4869
21MM FAST LEAD SOCKET	J4044
16MM (5/8") HEX SOCKET	J4090
15MM X 1/2 EXT SOCKET LA3H	J4213
17MM HEX SOCKET (SPEC. O.D.)	J4304
19MM X 80MM EXT SOCKET	J4316
19MM X 157MM EXT SOCKET	J4318
19MM X 18MM EXT SURFACE DR	J4381
17MM HEX SOCKET SURFACE DR	J4398
14MM FAST LEAD SOCKET	J4457
17MM X 19MM EXT SOCKET	J4467
22MM FAST LEAD SOCKET LA3H	J4607
17MM FAST LEAD SOCKET LA3H	J4608
9/16 X 1/2 EXT REACTION SOCKET	J4708
15MM X 1" EXT HEX SOCKET	J4829
TANG DRIVE SOCKET	S7749
22MM X 80MM EXT SOCKET LA3H	J4989
18MM X 80MM EXT SURFACE DR	L4067
21MM X 80MM EXT SURFACE DR	L4068
18MM X 157MM EXT SURF DR	L4073
11/16 HEX SOCKET	L4116
18MM 1/4" EXT (SPECIAL OD)	L4118
19MM HEX SOCKET LA3H	L4119
22MM X .52MM EXT HEX SOCKET	L4372
18MM X 80MM SURF DR SKT SPEC	L4426
19MM SURFACE DR SOCKET LA3H	L4474
11/16 SOCKET 36MM EXT	L4525
15MM SURFACE DR. SOCKET	J4662
16MM X 10MM EXT SOCKET	L4535
18MM SOCKET 1 1/2" EXT	L4556
22MM SURF DR SOCKET 10MM EXT	L4557
30MM HEX SOCKET LA4H	L4622
18MM X 19MM EXT HEX SOCKET	L4646

Description	Part No.
24 MM SOCKET 10 MM EXT	L4663
HEX SOCKET 21MM X 300MM	L4733
19 MM FAST LEAD SOCKET	L4868
19 MM SOCKET X 3/8" EXT	L4886
12MM HEX SOCKET (LA3H)	L4897
21MM SURF DR SOCKET 75 MM EXT	N4034
21MM SURF DR SOCKET 150 EXT	N4035
21MM SURF DR SOCKET	N4036
18MM X 37MM EXT SURF DR SOCKET	N4134
21MM X 37MM EXT SURF DR SOCKET	N4135
21MM X32MM EXT SURF DR SOCKET	N4136
21MM X 107MM EXT SURF DR	N4137
21MM X 80MM EXT SURF DR SOCKET	N4149
21MM X 157MM EXT SURF DR	N4150
20MM HEX SOCKET	N4177
21MM SURF DR SOCKET 67MM EXT	N4186
21MM HEX SOCKET X 1.531 EXT	N4188
21MM HEX SOCKET 8MM EXT	N4337
21MM HEX SOCKET 57MM EXTENDED	N4382
17MM X 87MM EXT SOCKET	N4398
15MM SURF DR SOCKET 37MM EXT	N4412
24MM SURF DR SOCKET	N4439
22MM SURF DR SOCKET	N4440
18MM HEX SOCKET 1/4" EXT	N4457
21MM X 8.5MM EXT. HEX SOCKET	N4466
18MM X 26.5MM EXT. HEX SOCKET	N4468
18MM HEX SOCKET 187MM EXT	N4696
18MM HEX SOCKET 107MM EXT	N4698
15MM X 80MM EXT. SURFACE DR.	N4582
18MM X 3-1/8" EXT HEX SOCKET	N4711
18MM HEX SURF DR SOCKET 80MM	N4715
15MM DBLE. HEX SOCKET	N4782
15MM HEX SOCKET (USE W/ N4826	N4825
18MM HEX SOC 1-1/2" EXT FAST	N4925
18MM HEX SOCKET FAST LEAD	N4926
17MM HEX SOCKET 10MM EXT	N4975
21MM SURF DR SOC 15MM DEEP	H4039
18MM SURF DR SOC 12MM DEEP	H4040
18MM SURF DR SOCKET	H4177
21MM SURF DR SOCKET 182MM EXT	H4366
17MM HEX SURF DR SOCKET 37MM	H4409
21MM SURF DR SOC 155MM EXT	H4447
21MM SURF DR SOCKET 10MM EXT	H4486
18MM SURF DR SOCKET 10MM EXT	H4487
17MM SURF DR SOCKET 1.5" EXT	H4576
17MM SURF DR SOCKET 1-5/8" EXT	H4594

Description	Part No.
18MM SURF DR OVER SIZE	H4612
18MM HEX SOCKET 32MM EXT	H4628
21MM HEX SOCKET 52MM EXT	H4629
17MM HEX SOCKET 36MM EXT	H4781
18MM HEX SOCKET 8" EXT	H4886
SOCKET 24MM X 45MM EXT.	H4820
17MM X 1-1/8" EXT SOCKET	H4959
14MM DBL HEX SOCKET	A6231
18MM HEX SURF DR X 1-1/2"	A6215
22MM HEX - A3H SPECIAL O.D.	A6216
22M SURFACE DRIVE - 1/4 EXT	A6228
15/16" X 60MM HEX SKT, 40A3H	A6270
21 MM SURF DR. X 2" SKT	A6467
19MM HEX SURF. DR. X 46MM EXT.	A6474
SOCKET 24MM X 8" EXT SURFACE	20D213700
21MM X 8.5MM EXT SURF DR - A3H	20D226300
SPECIAL 21MM X 80MM EXT.	20D232600
23MM HEX SOCKET, A40LA3H	20D232601
21MM X 8" EXT, HEX SKT ASM-H26	20D135900
27MM X 77MM EXT, H26 SKT	20D232606
7/8 HEX SOCKET	J4850
HEX SOCKET 1 1/8" SINGLE HEX	20D232609
HEX SOCKET,21MM X 67.6MM EXT.	20D232610
HEX SOCKET 21MM X 28MM EXT	20D232611
HEX SOCKET 34MM, H26	20D232612

LH26 Output Options *continued*

~H4948 Tang Holder Options

Description	Part No.
10MM HEX TANG HOLDER	H4948
8MM HEX TANG HOLDER	H4949
8MM HEX TANG HOLDER 8" EXT	H4982
10MM HEX TANG HOLDER 3.125"	H4983
12MM HEX TANG HOLDER	H4946
10MM HEX TANG HOLD 32MM EXT	H4960
10 X 12MM TANG HOLDER	A6004
10MM HEX FAST LEAD TANG HOLDER	A6030
TWO STEP TANG HOLDER	A6043
8MM TANG HOLDER 32MM EXT	A6053
7.1 X 8.25 MM TANG HOLDER	A6032
6MM X 8MM TANG HOLDER	A6089
5MM HEX TANG HOLDER	A6123
8MM HEX TANG HOLDER	A6132
8.7 X 11MM X 157MM EXT. TANG	A6203
8.0mm X 80mm EXT. A3H TANG	A6296
6.4MM X 8.4MM TANG HOLDER	A6288
10MM HEX X 2" EXT TANG	A6468
TANG HOLDER 12MM HEX X 8" EXT	20D213800
TANG HOLDER 11MM HEX X STD'D	20D215300
TANG HOLDER, 11MM SURFACE	20D216300
8MM HEX X 1.500 EXT TANG	20D216600
7MM X 1" EXT TANG HOLDER	20D223900
9MM FEMALE HEX TANG HOLDER	20D222701
TANG HOLDER 10MM SURF DR	20D245100
TANG HOLDER, .343 HEX	20D223901
7.7mm x 9.8mm RECT TANG HLDR	20D223902
10MM X 8" EXT, HEX TANG ASM	20D132303
10MM X 1-1/2" EXT, SURF DR TANG	20D245102
10MM X 7.5" EXT, SURF DR TANG	20D132304
E8 TORX TANG HOLDER,	20D226200
10MM X 32MM EXT, SURF DR TANG	20D245103
6MM HEX 6MM DEEP, TANG H26	20D245104
10MM X 67.6MM EXT, SURF DR, TANG	20D245108
10MM X 67.6MM EXT, HEX, TANG	20D245109
8.9MM X 11.2MM RECT TANG HOLDE	20D245110
10mm HEX, 64mm O'ALL LENGTH	20D245111
10MM X 55MM OAL TANG H22/H26	20D245112
TANG HOLDER, E12 TORX	20D226901

~H4947 H26 Bit Holder Options

Description	Part No.
HEX BIT HOLDER 5/16"HEX	H4947
BIT HOLDER 80MM EXT (FOR	N4670
BIT HOLDER 1/4" HEX X STD EXT	A6273
5/16" HEX BIT HOLDER 31MM EXT	N4631
HEX BIT HOLDER 5/16" X 1/4"	20D241300
HEX BIT HOLDER 5/16 HEX,	H4897
5/16" X 77MM EXT, BIT HOLDER	20D241301

~F4296 Bit Selection

Description	Part No.
7MM HEX BIT (FOR 5/16 HOLDER)	F4296
5MM HEX BIT (FOR 5/16 HOLDER)	F4380
6MM HEX BIT (FOR 5/16 HOLDER)	F4399
8MM HEX BIT (FOR 5/16 HOLDER)	F4513
5MM HEX BIT (FOR 1/4 HOLDER)	F4361
10MM MALE HEX BIT	L4259
5/16" HEX BIT (USE W/ F4360)	N4451
8MM HEX BIT (FOR 1/4" HOLDER)	N4991
T15 TORX BIT (FOR 1/4" HOLDER)	H4280
HEX INSERT BIT -SLOTTED (FOR	H4436
BIT FOR "XNZ" SCREW (FOR 5/16"	H4533
1/4" MALE HEX BIT (USE W/	A5668
3/8" MALE HEX BIT (USE W/	A5666
T27 TORX BIT 1/4" SHANK	A6134
7MM HEX BIT (FOR 1/4" HOLDER)	H4909
HEX BIT 14MM	A5724
6MM SQUARE BIT	A6206
6MM X 5MM BIT	A6207
HEX BIT-1/4 HEX 5/32 HEX	A6178
HEX BIT-1/4 HEX 3/16 HEX	A6179
T30 HEX BIT	A6341
HEX BIT - T40, MADE FROM X4248	A6373
HEX BIT-T50	A6403
HEX BIT -1/4 HEX	A6453
HEX BIT, T-45	20D240600
SLOTTED HEX BIT - 5/16" HEX	20D246700
HEX BIT, T30 (1/4" HOLDER)	20D240601
9MM HEX BIT, 1/4" HOLDER	20D240605
5/16" HEX BIT, 7/16" DRIVE	20D240606
T-30 BIT, SPCL LENGTH, 5/16 HLDR	20D240609
T-45 BIT, SPCL LENGTH, 5/16 HLDR	20D240610
6MM HEX BIT, 1/4" DRIVE, MACH	20D240611

These bits can be used in all H18, H22, H26 and H32 Bit Holders

Hold & Drive Socket, Bit & Tang Options

LH32 Output Options

~A5302 1" Travel Socket Options

Description	Part No.
21MM HEX SOCKET	A5302
1 3/16" (30MM) HEX SOCKET	A5306
1-1/8" HEX SOCKET	A5667
41MM HEX SOCKET	A5722
36MM HEX SOCKET	A5726
24MM HEX SOCKET	20D212101
27MM HEX SOCKET	20D212102
23MM HEX SOCKET	20D212103
22MM SURF DR SKT	20D212104

~A5303 2" Travel Socket Options

Description	Part No.
21MM HEX SOCKET	A5303
1 3/16" (30MM) HEX SOCKET	A5316
31MM HEX SOCKET	A5339
22MM HEX SOCKET	A5383
24MM HEX SOCKET	A5393
46MM HEX SOCKET	A5718
36MM HEX SOCKET	20D226700
24MM SURFACE DRIVE SOCKET	20D230100
34MM HEX SOCKET	20D235000
21MM X 16MM EXTENSION HEX SOCKET	20D249400
18MM HEX SOCKET	20D230101
24MM X 16MM EXTENSION HEX SOCKET	20D249401
30MM HEX SOCKET	20DS201800

~20D900602 Bit Holder Options

Description	Part No.
5/16" Hex	A5307
7/16" Hex	A5723
8 MM Special Outside Diameter	20D250100

~20D900601 Tang Options

Hex

Size	Extension	Part #	Feature
5/16" (8mm)		A5559	
8mm		20D212204	Special O.D.
10mm		A5301	
10mm	1/4"	A5452	
11mm		A5394	
12mm		20D212201	

Surface Drive

Size	Part #
10mm	A5581
11mm	A5549
12mm	20D212203
13mm	20D212202
15mm	20D212206

Fast Lead

Size	Extension	Part #
10mm		A5399
11mm		A5400
11mm	1/4"	A5453

Rectangle

Size	Extension	Part #
10.32 X 13.1mm		A5585
9 x 12.55mm	80mm	A5384

Torx

Size	Part #
T-18	A5340

Tools Data Manager

Tools Data Manager is a Comprehensive Manufacturing Data Management and Analysis Solution.

Tools Data Manager is designed to simplify the challenges of connecting, extracting, associating, archiving, analyzing, and mobilizing data generated by plant-floor devices. DC electric tool assembly, process and material handling PLCs, injection molding, painting/ curing, quality and testing such as Labview, and more are the types of systems from which Tools Data Manager aggregates manufacturing data into a single, central database. Tools Data Manager offers total control and collaboration of all the data which represents the manufacturing DNA of an operating plant.

Features That Deliver Real Value

Tools Data Manager's advanced data management, search, viewing and graphing features support efforts to leverage:

1. Record Keeping
2. Liability Mitigation
3. Product Quality
4. Error Proofing (Poke-Yoke)
5. Traceability (Data Quality)
6. Predictive Maintenance
7. Tool Management
8. Continuous Improvement (Kaizen)

The word **Kaizen** is Japanese and means
"Continuous Improvement"



Tools Data Manager collects information via an Ethernet network for industrial plant equipment such as:

1. Electric Torque Tools
2. Fill Stations
3. Alignment Stations
4. Operator Processes
5. Test Stations
6. Torque Audit Equipment
7. Plant PLCs



Tools Data Manager can seamlessly integrate into Quality, Broadcast, MES and Database systems to provide:

1. Equipment Program Selection
2. Operator Instructions
3. Data Alignment

Tools Data Manager organizes and presents the data in meaningful ways such as:

1. Exception Reports
2. Activity Reports
3. Data Graphs
4. Trend Graphs
5. Dashboard Meter and Gauges
6. Exported Spreadsheets

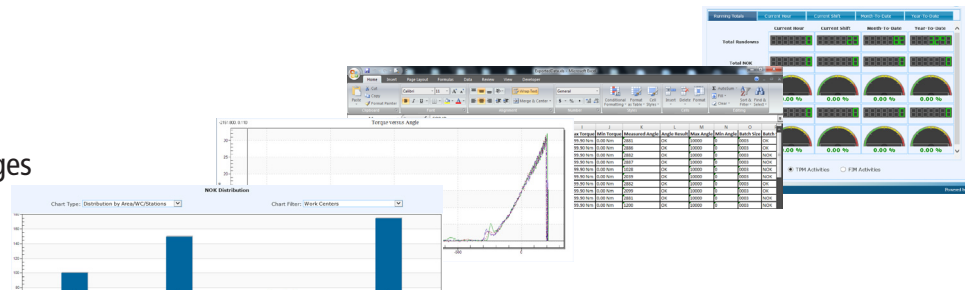

Networking - TDM

Function	TDM
Number of Licensed Spindles	20, Plant
QPM Q, QA, QB Controllers	✓
PSI-C Controllers	✓
Allows other Tool Controllers to report via Ethernet Only	✓
Standard PC Capable	✓
Server Environment	
Internal Database Only	✓
Other Commercial Databases	✓
End-of-Run data view and search	
Torque, Angle, Time, VIN Number (if Entered), Bolt Count	✓
Tool Temp, Total Cycles on Tool, Shut Off ID, Overall Result	✓
Torque and Angle Result, Spindle Number Tool Serial Number	✓
Trace Functionality X and Y Axis Selectable and Normalized Selection Units	
Torque, Angle, Time, Speed CommandSpeed,Buss Voltage, Current Limit	✓
Trace Viewing	
Live Traces	✓
Trace Storage	✓
View Historical Traces	✓
Historical Trace Overlay	✓
Export Trace	✓
Trace Zoom	✓
Trace Section Save	✓

Function	TDM
Data Storage, Review and Output	
Datapoints Recorded	✓
View on Screen Live	✓
Data Search Engine	
Print from Application	✓
Export Historical Data to CSV	✓
Real Time Database Export	✓
Configurable TCP/IP Data Export	✓
Configurable Export - Groups	✓
Configurable Export - Devices	✓
Process Overview	
Separate Monitor Window	✓
Device Overall Status - Red/Green Lights	✓
Click for Trace View	✓
Click For Last N Rundowns	✓
Device Datapoint Statistics	
Mean - X- Bar, Sigma, Range, Min, Max	✓
-3 Sigma, +3 Sigma, 6 Sigma, Median	✓
Trending Analysis	✓
Device Management	
Time Push to Controllers	✓
Internet Browser Support For Viewing And Admin	
Remote Access to SW through Web Browser	✓
On-site Installation and Support	
Phone Support Included	2 hours
On-Site Start up Required	✓
On Site Included	Per Quotation

Mounting Options

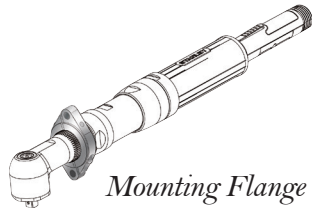
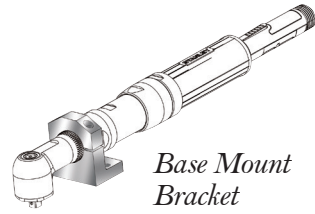
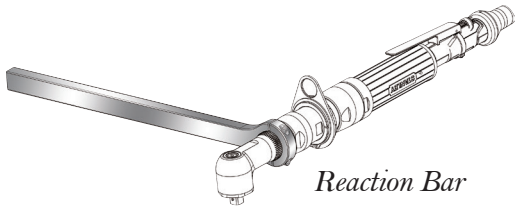

Reaction Devices Listed by Tool Models	E_02LB E_12LB E_12PB EB22PB	EB22LB E_33LB E_33MB E_33PB	E_33LA19 E_34LA19 E_34LA22A/H22A E_34LC/EB34LT E_44LA19 E_44LA22A/H22A E_44LC/EB44LT E_34LB1 E_34MB1 E_44LB1 E_44MB1 E_34PB1 E_44PB1	E_45LA26/H26 E_45LA32/H32 E_55LA26/H26 E_55LA32/H32 E_45LB2 E_45MB2 E_55LB2 E_55MB2	E_55LB3 E_55MB3	E_55LB4 E_55MB4	E_55LB5 E_55MB5
Base Mount Bracket		A8606	20K100500	20K100600	H1140	F4201	
Mounting Flange		20K101000	20K100300	20K100700	M4329	20K101100	20K100900
Reaction Bar - Steel	20K100104	20K100100	20K100000	20K100200	B4487	F4192	
Reaction Bar - Heavy Duty				20K100202			
Reaction Bar 17" - Aluminum	20K100103	F3698					
Reaction Bar 12" - Aluminum	20K101601						
Sliding Drive Reaction Bar						F4857	

Tool Bails

Wire Bails allow a tool to be hung on a hook for storage until needed.

Swivel Bails allows for a balancer to hold the weight of the tool while the operator uses the tool in the correct position as the tool is free to rotate inside the bail.

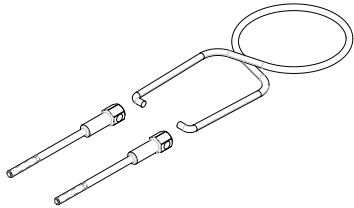

Vertical Bail
Mount Kit

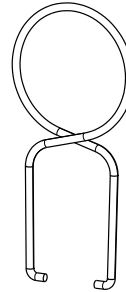

Wire Bail

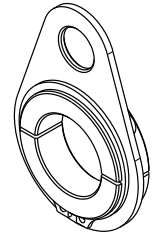

Swivel Bail

Bail Devices Listed by Tool Models	E_02LA E_02LB E_12LA E_12LB	EB22P	E_33P	EB22L E_33L	E_34P E_44P	E_34L E_44L	E_45L E_55L
Swivel Bail	20K101402		20K101400	20K101400	20K200000	20K200000	20K200100
Vertical Wire Bail	A3061	A3061	A3061	A3061	A3061	A3061	
Vertical Bail Mount Kit			20K200007		20K200007		

Gear Case Extensions for Angle Tools

Gear Case Extensions fit between the gearing and an angle output to extend the reach of the tool.

Use these Part Numbers to extend an existing tool. When ordering a new tool simply use E# after the tool model number to have the extension installed on the new tool. Where # is the length in inches for the extension required.

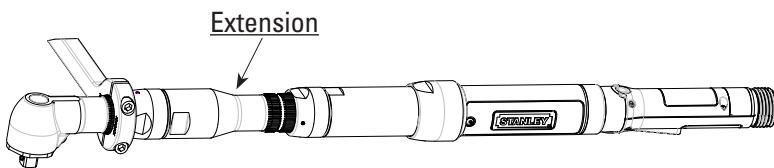

Tool Type	Gearing Size	Output	Extension	Part Number
E12/ EB_2/ AA	G2	A10/ A13	2"	20K300026
E12/ EB_2/ AA	G2	A10/ A13	6"	20K300027

Tool Type	Gearing Size	Output	Extension	Part Number
EB/ AA	G3	A15/ A18/ A19 Threaded	4"	20K300028
EB/ AA	G3	A15/ A18/ A19 Threaded	6"	20K300029
EB/ AA	G3	A15/ A18/ A19 Threaded	8"	20K300030
EB/ AA	G3	A15/ A18/ A19 Threaded	10"	20K300031
EB/ AA	G3	A15/ A18/ A19 Threaded	12"	20K300032

Tool Type	Gearing Size	Output	Extension	Part Number
E	G3	A15/ A18/ A19 Threaded	4"	20K300019
E	G3	A15/ A18/ A19 Threaded	6"	20K300025
E	G3	A15/ A18/ A19 Threaded	10"	20K300020

Tool Type	Gearing Size	Output	Extension	Part Number
E/ EB/ AA	G4	A19 Splined/ A22A	4"	20K300014
E/ EB/ AA	G4	A19 Splined/ A22A	6"	20K300013
E/ EB/ AA	G4	A19 Splined/ A22A	8"	20K300015
E/ EB/ AA	G4	A19 Splined/ A22A	10"	20K300016
E/ EB/ AA	G4	A19 Splined/ A22A	12"	20K300018

Tool Type	Gearing Size	Output	Extension	Part Number
E/ EB	G5	A26/ A32	6"	20K300006
E/ EB	G5	A26/ A32	9"	20K300009
E/ EB	G5	A26/ A32	12"	20K300012

Guided Collar Ergonomic Accessories

Guided collars minimize tool vibration from sockets and extensions. Independent tests show Guided Extension Collars reduce vibration by 72%! Guided Collar Accessories can help to improve:

- **Ergonomics** - significantly reduce the transfer of vibration to the operator
- **Safety** - minimize the pinch hazard between the tool and the extension
- **Product Quality** - reduce the potential for product damage by helping to prevent tool contact with finished surfaces and cross-threading caused by improper fastener installation
- **Tool Torque Quality** - assure more consistent driving torque and improve capability
- **Tooling Reliability** - Guided collar accessories incorporate a heavy duty bearing that minimizes wobble and reduces side loading to reduce premature tool wear and improve tool reliability
- **Attachment Lifecycle** - extends socket and extension life

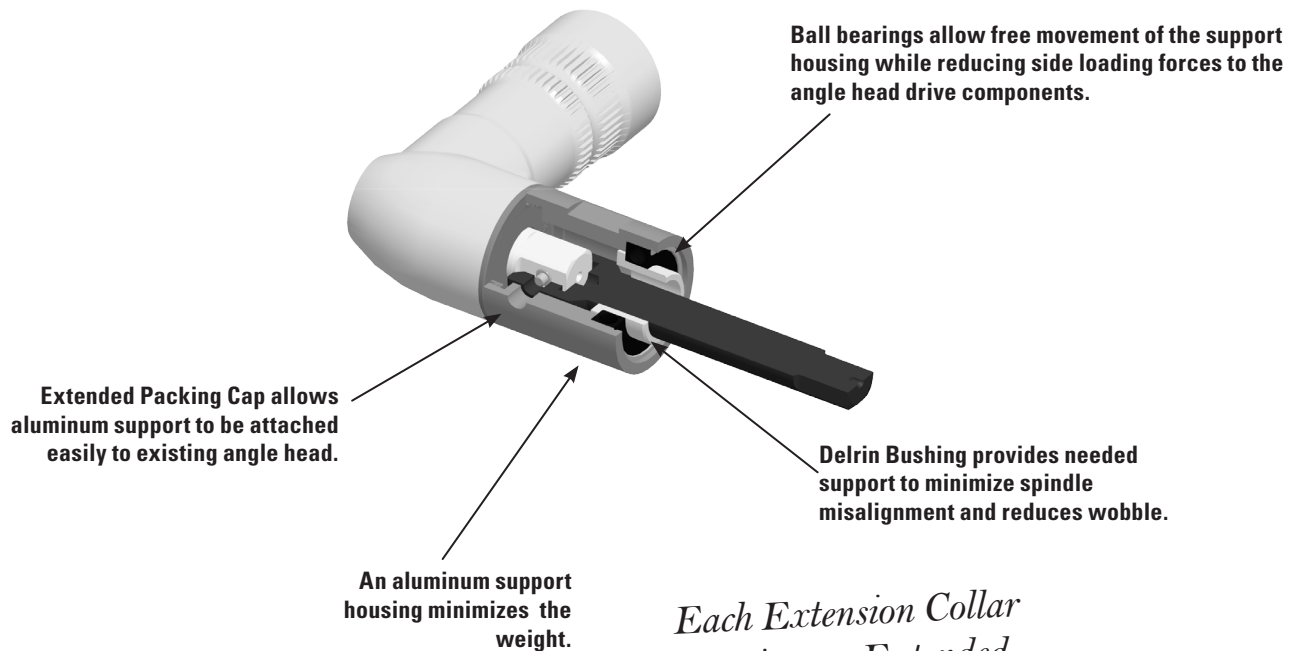

Each Extension Collar requires an Extended Packing Cap from the table on the right.

Guided Extension Collar Assemblies*

Output	Square Drive (in)	4" Extended Spindle	6" Extended Spindle	8" Extended Spindle	12" Extended Spindle
A14	3/8"	20K102504		20K102505	
A15	3/8"	20K102506	20K102508	20K102507	
A18	3/8"	20K102500	20K102509	20K102501	20K102511
A19	1/2"	20K102502		20K102503	

Extended Packing Caps

Output	Part Number
A14	20D140102
A15	20D140103
A18	20D140100
A19	20D140101

*Includes collar and extension

ErgoTorq™ Pinchpoint Protectors

Minimize operator pinch hazard at the socket-tool interface. Rugged, reliable ErgoTorq™ PinchPoint Protectors are easy to install and use:



Pinchpoint Protector

- PinchPoint Protectors replace standard packing caps on QPM angle head outputs
- Rugged UHMW polyethylene sleeved construction provides outstanding strength and durability
- I.D. clearance allows sockets to turn freely
- Hollow lock set screws enable access to the square drive release pin for fast, easy socket installation and removal

QPM PinchPoint Protectors

Output	Square Drive (in.)	Part Number
A13	3/8"	20D243002
A14	3/8"	20D243103
A18	3/8"	20D243202
A18	1/2"	20D243205
A19	3/8"	20D243302
A19	1/2"	20D243305
A22	1/2"	20D243405

ErgoTorq™ is a registered trademark of Ergonomic Specialties

Protective Head Covers



PVC Cover



Vinyl Cover

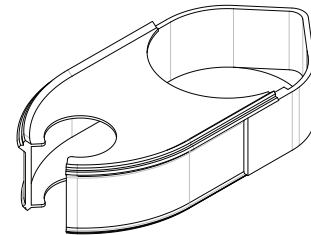
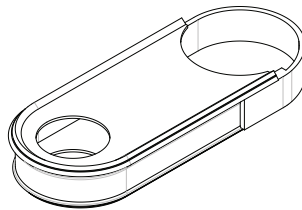

Crowfoot Vinyl Head Covers

Crowfoot Output	Angle Head Cover	Foot Cover
C7	20D250707	20D250722
C8	20D250705	20D250723
C10	20D250708	20D250712
C13	20D250703	20D250714
C16	20D250707	20D250715
C29	20D250702	20D250718
C31	20D250708	20D250719
C35	20D250702	20D250720
C69	20D250702	20D250721
C106	20D250702	20D250713
C246	20D250702	20D250717

Tubenut Vinyl Head Covers

Tubenut Output	Angle Head Cover	Foot Cover
T20	20D250708	20D250725
T23	20D250707	20D250727
T74	20D250702	20D250729
T99	20D250707	20D250730
T147	20D250702	20D250724
T211	20D250702	20D250726
T264	20D250702	20D250728

Angle Head Covers

Angle Output	PVC Cover	Vinyl Cover
A13	X2300	20D250705
A14/ A15	X2322	20D250701
A18S	X2323	20D250702
A19	n/a	20D250707
A22	X2305	20D250708
A26	X2306	20D250709
A32	n/a	20D250710

Lever Handle Options

Rubber Grip for Handle

Handle Type	Tool	Part Number
Pistol	E_02P	20H207107
	E_12P	
	E_2_P	
	E_3_P	
Lever	E_02L	20H207910
	E_12L	20H207207
	E_2_L	
	E_3_L	
	E_4_L	
E_5_L		
Push-to-Start	E_02LP	20H207915
	E_12LP	

Forward Facing Lever

Handle Type	Tool	Part Number
Lever	E2/3_L	20H100005
	EA2/3_L	20H100008
	E4/5_L	20H100105
	EB3/5_L, B1/2_L	20H100107
	EB22L	20H100108

Extended Lever

Handle Type	Tool	Part Number
Lever	E_0/12_L	20H102201
	E_2/3/4/5_L	20H100007



Forward Lever

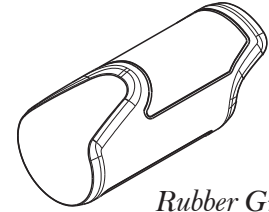

Rubber Grip

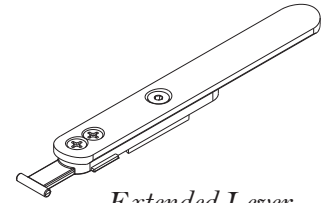

Extended Lever

Headlights

Tool LED Headlight

Tool	Light Type	Headlight No.
E12 HD/EB12	Stationary	20S113200
E12		20S113202
EA/EB		20K101802
EA3/EB3	Adjustable	20S113201
E12/EB12	Flexible Wand	20K101804
E2/E3		20K101800
EA3/EB3		20K101803

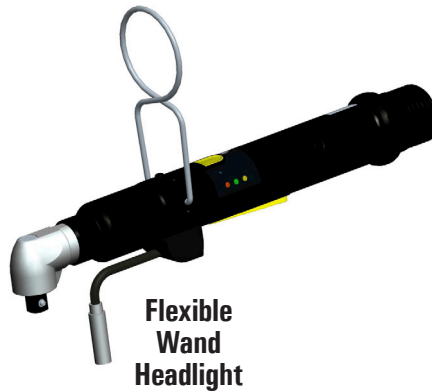

Flexible Wand Headlight

DC Tool Accessories - Socket Trays



Socket Trays

STANLEY's 4 and 8 position Socket Trays, available in 24V DC or DeviceNet models, allow a single tool to reliably assemble joints at different target torque levels, batch counts or fastening strategies maximizing quality, productivity, efficiency and floor space. Features include:

- **Optical Sensors for Maximum Lifespan**
- **Poka-Yoke error proofing for same external socket sizes (Optional)**
- **I/O repeater provides access to controller 24V DC I/O not consumed by the Socket Tray (Optional)**
- **Compact design for Maximum space saving**
- **Ready for Alpha and PSI Controllers using Binary +1 selection**

Socket Tray Model Number	# Socket Positions	Connection	Repeater Port	Cable	Max Socket Diameter
SA-1980	4	24V DC I/O	No	24V DC I/O cable Required, See Below	54 mm 2-1/8"
SA-1981	8		No		
SA-1982	4		Yes		
SA-1983	8		Yes		
SA-1978	4	DeviceNet	No	DeviceNet Cable and Tee Required, See Below.	
SA-1979	8		No		

When using multiple sockets and programs please ensure that the torques programmed are within the working specifications of the tool and controller used.

8-Position socket tray dimensions: 216d x292w x163h mm (8.5 x 11.5 x 6.4 in)

Cable Number	Connection	Controller	Length
20C109007	24V DC I/O	Advanced/Expert	7 meters
20C109010			10 meters
20C109107		Basic	7 meters
20C109207		PSI-C	7 meters
21C1021.2	DeviceNet	DeviceNet Master	0.2 meters
21C102101			1 meters
21C102105			5 meters
21C102110			10 meters
21C102120			20 meters

Kit Number	Description
21C101401	DeviceNet Cable Tee/ Terminator Kit
21C101403	DeviceNet Cable Kit - 0.2 meter Extension
21C101404	DeviceNet Cable Kit - 1 meter Extension

DeviceNet Micro Tee - 21R202204

DeviceNet Micro Terminator Male - 21R202202

DeviceNet Micro Terminator Female - 21R202203

Training Joint Simulator

Part Number 20V101000 Has three 1/2" - 13 Bolts with Hard Medium and Soft Joints. Can be mounted to table tops or other significant structures for learning different strategies on different joint characteristics.



20V101000

Calibration Joint Simulator

Model	Joint Type	Max Input Torque		Torque Rate		Bolt Size
		Nm	ftlb	Nm/°	ftlb/°	
T00915/S3	Soft	60	45	14	10.3	3/4 - 16
T00915/S4		88	65	22.6	16.7	
T00915/S5		135	100	34	25	
T00915/S6		200	148	50	37	
T00915/H1	Hard	20	15	125	92.4	5/8 - 11
T00915/H2		40	30	285	210	
T00915/H3		54	40	405	300	3/4 - 16
T00915/H4		75	55	610	450	
T00915/H5		135	100	950	700	
T00915/H6		200	148	1700	1257	



Calibration Joint Simulator

Torque Validation Module (TVM)

The TVM is a torque transducer designed to handle the most rugged torque tools available and provide actual torque reading that are N.I.S.T. traceable. Extremely robust and employing an easily replaceable Grade 8 hex head cap screw and nut, the TVM is ready to take on any impact tool pulse tool or direct-drive tool within its range. The portability of the TVM allows you to set up pulse and impact tools using the same extensions and adapters that will be used on the job.

- Heavy-duty design - stands up to impact wrenches
- Easy to replace worn items
- Dead weight calibrated; N.I.S.T. certificate of calibration
- Adjustable joint rate
- Can be used with Industry Standard torque transducer indicators

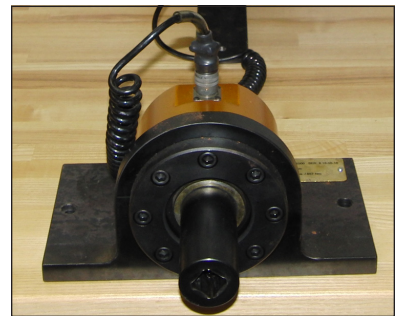

The portability of the TVM allows you to set up pulse and impact tools using the same extensions and adapters that will be used on the job.

TVM

Model	Range Nm	Range ftlbs	Angle Range
TVM-40	8 - 40	5.9 - 28	5 - 360
TVM-180	36-180	26 - 130	10 - 450
TVM-350	72 - 350	53 - 245	20 - 720
TVM-800	160 - 800	118 - 590	60 - 760
TVM-2200	440 - 2200	324 - 1622	60 - 360

Compatible Cables

Model	To Use With
24C502002	PSI-A or Industry Standard Torque Transducer Indicators
24C504402	Crane Torque Star Torque Indicators

DC Tool Accessories - Test Fixtures, Handles



PSI-A

The PSI-A provides for precise torque validation of power tools for assembly when used with an external torque transducer. This allows operators to easily adjust the power tool and quality inspectors to certify and record tool performance.

Compact in design, the PSI-A provides operator feedback via a large digital display for torque value and status. The PSI-A is easy to program and has optional network-ready hardware available for digital data transfer. It has individual, selectable parameter-sets for each of the TVM transducers.

If using an industry standard torque transducer other than a TVM, choose a compatible cable from the list below.

Power Supply by Country

Country	Voltage	Current	Part # to Order
Japan	100 VAC	1 Amp	24X500143
Australia	240 VAC	1 Amp	24X500144
United Kingdom	240 VAC	1 Amp	24X500145
Europe	220 VAC	1 Amp	24X500146
U.S.A.	110 VAC	1 Amp	24X500092

Compatible Cables

Part No.	Cable Description
24C502108	25 foot Industry Standard Cable
24C502211	35 foot Industry Standard Cable
24C502316	50 foot Industry Standard Cable

DC Start Handle

Use Part Number M4504 as a second handle for positioning tools that are fixtured and then starting their operation. Use one of the X5380/x cables listed with this handle.

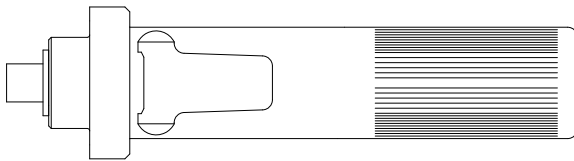
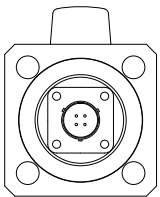

Part No.	Length
X5380/1	1 meter
X5380/3	3 meters
X5380/10	10 meters
X5380/30	30 meters
X5380/60	60 meters

Auxiliary Handle

Use Part Number S3544 as an Auxiliary Handle for positioning tools that are fixtured.

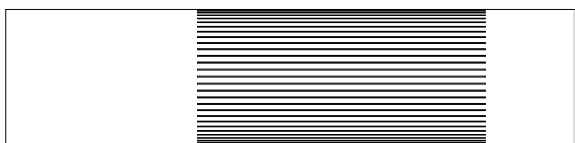
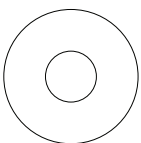

Floor Stands

Floor Stands provide a place for mounting groups of controllers typically found in fixtured tool applications. However, handheld tools could also be grouped for convenience.

Model	Max Number of Spindles	Description
21F100405	2	For controllers and a Power Module
21F100406		For controllers only
21F100403	6	For controllers and a Power Module
21F100404		For controllers only
21F100401	12	For controllers and a Power Module
21F100402		For controllers only

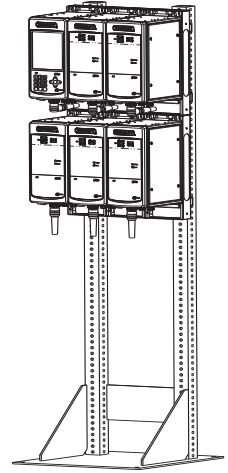

DC Tool Accessories - Maintenance Tools

Assembly/ Disassembly Maintenance Tools

Spanner or Crowfoot Wrench

Description	Part No.
3/4" x 3/8" SD	X4174
1" x 3/8" SD	X4175
1-1/16" x 1/2" SD	X4176 / X4212
1-1/8" x 1/2" SD	X4177 / X4213
1-1/4" x 1/2" SD	X4179 / X4214
1-3/8" x 1/2" SD	X4181
1-7/8" x 1/2" SD	X4186 / X4218
2" x 1/2" SD	X4187 / X4220
2-5/16" x 1/2" SD	X4189 / X4209
2-1/4" x 1/2" SD	X4190 / X4208
2-3/16" x 1/2" SD	X4191 / X4207
1-3/8" x 1/2" SD	x4192

Description	Part No.
1-1/2" x 1/2" SD	X4193
1-5/8" x 1/2" SD	X4194 / X4183
1-3/4" x 1/2" SD	X4195
1-3/16" x 1/2" SD	X4196 / X4188
1-13/16" x 1/2" SD	X4197
1-11/16" x 1/2" SD	X4200 / X4217
1-15/16" x 1/2" SD	X4201 / X4219
1-7/16" X 1/2" SD	X4204
1-9/16" x 1/2" SD	X4205
1" X 1/2" SD	X4211
1-5/16" x 1/2" SD	X4215
1-7/16" x 1/2" SD	X4216

Description	Part No.
2-1/2" x 1/2" SD	X4210 / X4222 / 20V200001
2-15/16" x 1/2" SD	20V200002
2-3/4" x 1/2" SD	20V200003
2-7/8" x 1/2" SD	20V200004
3-3/8" x 1/2" SD	20V200005
2-1/8" x 1/2" SD	X4206 / X4221 / 20V200006
3" x 1/2" SD	20V200007
3-1/4" x 1/2" SD	20V200008
3-1/4" x 1/2" SD	20V200008

These spanners are used to assemble or disassemble the lock nuts and outputs of QPM tools. See the specific tool's Assembly Sheet for which spanner to use on the tool.

Output Assembly/ Disassembly Tools

Description	Part No.
A13 PACKING CAP ASSEMBLY TOOL	T00576
A14 PACKING CAP ASSEMBLY TOOL	20V200400
A18 PACKING CAP ASSEMBLY TOOL	T00698
A19 PACKING CAP ASSEMBLY TOOL	20V100201
A19 BEARING PRESS AID	20V100202
A19 BEARING PRESS AID	20V100209
A22 BEARING PRESS AID	20V100203
A26 BEARING PRESS AID	20V100206
A32 BEARING PRESS AID	20V100207
A14 PINION PULLER	T05108
A19 / A22 PINION PULLER	20V100400
A26 / A32 PINION PULLER	20V100401

These tools are used to Assemble/ Disassemble the outputs of the QPM DC tools. See the specific tool's Assembly Sheet for which spanner to use on the tool.

Motor Connector Repair Kit

Description	Part No.
E TOOL CONNECTOR REPAIR KIT	20M202900
EA, EB, EC TOOL CONNECTOR REPAIR KIT	20M202901

Miscellaneous Tools

Description	Part No.
A30 / A40 / A18 Drive Spindle Pusher	T01849
SPANNER WRENCH	T05389
T30 BIT (USE W/ 5/16" HOLDER)	X4198
E3 MOTOR CLAMP	20V100001
E3 THREADED ADAPTER SPANNER	20V100002
E4 / E5 MOTOR CLAMP	20V100101
E4 / E5 THREADED ADAPTER SPANNER	20V100102
E12 HD KIT INSTALL SPANNER	20V100210
QPM CONNECTOR REPAIR TOOL KIT	20V100300
MOTOR TESTER, 115V AC	20V100600
MOTOR TESTER, 230V AC	20V101100

These tools are used to repair or test QPM DC tools. Attend Tool Repair Training to learn how to use these tools.

Test Boxes

Description	Part No.
Tool Cable Test Box - Use this box to test the continuity in the transducer cable.	24K500274
Tool LED Test Box - Use this box to test the continuity in the transducer in the tool and to test the LEDs on the tool.	24K500275

Software

Description	Part No.
Data Collection Transfer Kit - This computer software is used to pull data stored in the DTU.	24K500340
JTAG Service Kit - This computer software is used to update the firmware of the PSI equipment.	24K500487

Bails

Description	Part No.
AH30PB-40 / -65	24Y501305
AH40PB-120	24Y501306
AP60PB-700	24Y500290

Hangar Brackets

Description	Part No.
AT40PB(M)-175	24R501540
AT40PB(M)-335	24Y500964
AT60DB(M)-675, AT64DB(M)-675	24Y500966
AT60PB(M)-675, AT64PB(M)-675	24Y500965
AT84DB(M)-1500	24Y500967
AT86DB(M)-2200	24R501496

Hydraulic Tool Oil

Description	Part No.
Red Pulse Tool Oil, 1 Quart	24K500494

Extension Hose with Quick Exhaust Valve

Description	Part No.
25 Feet 3/8" Hose/Cable	24C505508
25 Feet 1/2" Hose/Cable	24C505708

Miscellaneous

Description	Part No.
Controller Stand	24K500279
Bar Code Adapter Kit - PSI-C	24K500507
Bar Code Reader/Scanner Kit	24K500500
Data Transfer Unit / Memory Expansion	24K500172
Remote Parameter Set Select Switch Box	24K500372
PSI-Q Throttle Pin for AA2/ 3 Tools	20H211201
AA Tool PSI-Q Integration Kit	24K100300

24K500078 AH30PB-20 Pulse Pack Repair Kit *consists of:*

Description	Part No.
Supporting Ring	24Y500763
O-Ring, ID. .077", Thick 0.058"	24R500755
Supporting Ring	24Y500762
O-Ring ID 1.15", Thick 0.069"	24R500757
O-Ring ID 0.059", Thick 0.060"	24R500756
O-Ring ID 1.117", Thick 0.069"	24R500754
O-Ring ID 0.462", Thick 0.090"	24R500753
Pulse Spring Thick	24Y500747

24K500084 AH30PB-20 Air Motor Repair Kit *consists of:*

Description	Part No.
Ball Bearing (B-11)	24Y500751
Ball Bearing (B-12)	24Y500752
Blade-Motor- AH-20	24M500724

24K500079 AH30PB-40 Pulse Pack Repair Kit *consists of:*

Description	Part No.
Pulse Spring	24Y500623
Supporting Ring (ASR-16)	24Y500762
O-RING, ID. 1.15", Thick .069"	24R500757
O-RING, ID. .462", Thick .90"	24R500753
O-RING, ID. 1.117", Thick .069"	24R500754
Supporting Ring (ASR-5)	24Y500763
O-RING, ID. .077", Thick .058"	24R500755
O-RING, ID. .059", Thick .060"	24R500756

24K500085 AH30PB-40 Air Motor Repair Kit *consists of:*

Description	Part No.
Ball Bearing (B-39)	24Y500625
Blade	24M500773
O-RING, ID. 1.548", CS. .082"	24R500628
Ball Bearing (B-13)	24Y500626

24K500329 Repair Tooling Set *for the AH30PB-40 and -65 consists of:*

Description	Part No.
Holder-Pulse Unit	24K500310
Spanner-Rear	24K500246
Box Nut Spanner-Pulse Unit	24K500067

24K500080 AH30PB-65 Pulse Pack Repair Kit *consists of:*

Description	Part No.
O-RING, ID. 1.117", Thick .069"	24R500754
O-RING, ID. .077", Thick .058"	24R500755
Supporting Ring (ASR-16)	24Y500762
O-RING, ID. .059", Thick .060"	24R500756
O-RING, ID. .462", Thick .90"	24R500753
O-RING, ID. 1.15", THK. .069"	24R500757
Pulse Spring	24Y500623
Supporting Ring (ASR-5)	24Y500763

24K500086 AH30PB-65 Air Motor Repair Kit *consists of:*

Description	Part No.
Ball Bearing (B-13)	24Y500626
Ball Bearing (B-39)	24Y500625
Blade- AH-65	24M500608
O-RING, ID. 1.548", CS. .082"	24R500628

24K500081 AH40PB-120 Pulse Pack Repair Kit *consists of:*

Description	Part No.
Supporting Ring;	24Y500768
O-RING, ID. .626", Thick .098"	24R500814
Supporting Ring (ASR-5)	24Y500763
O-RING, ID. .077", Thick .058"	24R500755
O-RING, ID. .492", Thick .079"	24R500815
Spring - Pulse	24Y500812
O-RING, ID. .059", Thick .060"	24R500756

24K500087 AH40PB-120 Air Motor Repair Kit *consists of:*

Description	Part No.
Ball Bearing (B-2)	24Y500813
O-RING, ID. 1.986", Thick .078"	24R500817
Ball Bearing (B-13)	24Y500626
Blade-Motor- AH-120	24M500793

24K500330 Repair Tooling Set

for the AH40PB-120 consists of:

Description	Part No.
Spanner -Rear- AH-120	24K500247
Spanner-Pulse Unit - AH-120	24K500311
Holder-Pulse Unit- AH-120	24K500312

A

Absolute Position Sensor 124
 Accessories
 Auxiliary Handle 180
 DC Start Handle 180
 Floor Stands 181
 Head Covers 176
 Lever Handle Options 177
 Mounts 173
 PSI 183
 Test Fixtures 179
 Accuracy 13
 Advanced 18
 Alpha 14–21
 Advanced 18
 Basic 16
 Expert 20
 Gateway 16
 Node 22, 23, 24
 Standard 17
 Toolbox 14–21
 Angle 10, 31–34, 71, 81, 176
 Retractable 55–57, 82–83
 Angle Control 124
 Arms 95
 Articulating 101–105
 ATC 13
 Auxiliary Handle 180

B

Bails 174, 183
 Basic 14
 Battery 25
 Bolt-Holding 94

C

Cable
 High Flex 90, 91
 Power 15
 Tool 25, 26, 27, 28, 29, 90,
 90–91, 91
 CE Compliance 3
 Clutch 110
 Color Display 18, 20
 Controller 16–21
 Control Methods 8
 Cordless 25
 Crowfoot 10, 42–47, 60, 76, 95,
 129, 130, 131, 132, 150,
 151, 176
 Custom Configurations 95

D

Data 16, 118
 Fastening Cycles 16–18, 20,
 22, 118

Trace 16, 18, 20
 DC Start Handle 180
 DeviceNet 19, 21, 119
 Diagnostics 16–18, 20

E

eCoDrive Sockets 133–147
 Engineered Solutions 92
 Turnkey 93
 Ergonomic 4, 93, 110, 120, 133
 Error Proof 96, 116, 119
 Ethernet 16–21, 118
 EtherNet/IP 19, 21, 119
 Expert 14, 20
 Extensions 30, 70, 174

F

Fieldbus 18, 20
 Fixtured 9, 54, 80
 Floor Stands 15, 181
 Flywheel Indexer 95

G

GM Ports 19, 21

H

Hand Held 9
 Head Covers 176
 Headlights 177
 High-Torque Crowfoot 95
 Hold and Drive 10, 52–53, 61,
 78–79

I

Inline 11, 38–41, 58–59, 74–75,
 75, 84–85, 112
 Retractable 62–66, 86–87
 I/O Cable 15
 ISO Certification 3

L

Lever Handle Options 177

M

Maintenance Tools 182
 Modbus/TCP 16–21
 Mounts 173
 MTBF 110
 MTTR 30, 70, 110
 Multi-Spindle 94

N

Networking 170, 171
 Node 22, 23, 24

O

Offset
 Retractable 67–69, 88–89
 Overhead Bridges 106, 107, 108

P

Partnering 5
 Pedestals 109
 Pistol 10, 25, 35–36, 73
 PLC 18–21, 118
 Editor 18–21
 Plinth 15
 Pneumatic 110, 116
 Power Cord 15
 Power Sources 8
 Preventive Maintenance 4
 Productivity 93, 120
 Profibus 19, 21, 119
 Profinet 19, 21
 Project Management 94
 PSI 120, 122, 183
 Cables & Hoses 127
 PSI-A 180
 PSI-C 118
 PSI-Q 116
 PSI-Qc 116
 Pulse Monitoring 123, 125
 Pulse Tools 121, 123
 Pus-to-Start 38

Q

Quality 2, 93, 120

R

Reaction Bars 173
 Recalibrating Tools 5
 Repair 5, 183

S

Semi-Automation 94
 serial 118
 Serial 16–20
 Sockets 133–146
 Adapter 144, 145
 Bit 147
 Bit Holder 147
 Crowfoot 130–139, 132–141,
 150–159
 Extension 144, 145
 Flush Angle 160–163
 Hold & Drive 164–169
 Impact 133
 Pulse 133
 Quick Change 143
 Taper-Lok 148, 149, 150

Torx 146
 Tubenut 151, 152, 153, 154,
 155, 156, 157, 158, 159,
 160
 Socket Tray 178
 Solutions 96
 Statistics 16, 17, 18, 20
 Strategies 16–18, 20, 22, 23, 95
 Support 5
 Swing Bar 37

T

Taper-Lok 148, 149, 150
 TDM 171, 172
 Test Fixtures 179
 Tool
 AA Series 110–115
 AA Angle 111
 AA Crowfoot 114
 AA Hold & Drive 113
 AA Inline 112
 DC Electric 30, 70
 PSI 120–127
 Hydraulic Pulse 123
 Mechanical Pulse 123
 Pin Clutch Impact 125
 Twin Hammer Impact 126
 Pulse 121–123
 Tools Data Manager. *See* TDM
 Torque Tubes 98–100
 Torque Validation Module 179
 Touchscreen 20
 Training 5
 Transducer 118, 120
 Trunnion 94
 Tubenut 11, 48–51, 77, 151, 176
 Turnkey 94
 TVM 179

U

USB 16–21

V

Vertical Balancers 97

W

Wheel Bearing End-Play 95

Mechanical Products Limited Warranty

STANLEY Black & Decker, Inc. ("STANLEY") warrants its Assembly Technologies mechanical products to the original purchaser to be free from deficiencies in material or workmanship for the useful life of the product.

Under this lifetime limited warranty STANLEY will, at its discretion, repair or replace any product which, upon inspection, is acknowledged by STANLEY to be defective.

This limited lifetime warranty shall apply to products which have been used under normal operating conditions for their intended use and shall not apply to products which have been subjected to: abnormal wear and tear, abuse, misuse, improper maintenance, negligence, continued use after partial failure, accident, alterations or repairs with non-genuine STANLEY replacement parts.

Electronic Products Limited Warranty

STANLEY warrants its Assembly Technologies electronic products to the original purchaser to be free from deficiencies in material or workmanship for a period of one year after the date of shipment.

Under this limited warranty STANLEY will, at its discretion, repair or replace any product which, upon inspection, is acknowledged by STANLEY to be defective.

This warranty shall apply to products which have been used under normal operating conditions for their intended use and shall not apply to products which have been subjected to: abnormal wear and tear, neglect, component degradation, improper handling, overload, abuse, misuse, improper maintenance, use with improper accessories, or where alterations have been made.

Software Products Limited Warranty

STANLEY warrants its Assembly Technologies software products to the original purchaser to be free from deficiencies in material or workmanship for a period of one year after the date of shipment.

Under this limited warranty STANLEY will, at its discretion, make available replacement software or an upgrade for any product which, upon inspection, is acknowledged by STANLEY to be defective. Installation of the software shall be the responsibility of the requestor.

This warranty shall apply to products which have been used with specified, compatible hardware under normal operating conditions for their intended use and shall not apply to products which have been: modified, misused, improperly handled, improperly maintained, or used with non-compatible hardware or accessories.

OEM Products Limited Warranty

Some STANLEY Assembly Technologies custom engineered systems include components manufactured by others. The limited warranties of each individual manufacturer shall apply to these components and STANLEY makes no representation or warranty of any kind, expressed or implied, with respect to such components.

General Terms

This limited warranty gives you specific legal rights and is in lieu of all other warranties, expressed or implied, including the implied warranties of merchantability and fitness for a particular purpose. Some states and countries do not allow limitations on implied warranties, so the above may not apply to you. You may also have other rights which vary by state or country.

STANLEY shall not be responsible for incidental or consequential damages or the inability to use its products for any purpose whatsoever. STANLEY's maximum liability shall not in any case exceed the contract price for the products claimed to be defective. Some states and countries do not allow the exclusion or limitation of incidental or consequential damages, so this specific limitation or exclusion may not apply to you.

Specification Changes

STANLEY retains the right to discontinue and/or change specifications of any Assembly Technologies products without responsibility for incorporating changes in products already sold.

Warranty Claims

To apply for warranty consideration, the original purchaser should take the following action:

- a) Contact the STANLEY Assembly Technologies customer service department to obtain a "Return Authorization Number" and "Warranty Claim Report Form."
- b) Package the product including proof of purchase and the completed warranty claim form.
- c) Note the Return Authorization Number on the exterior of the package and return freight to:

STANLEY Assembly Technologies

Central Repair Facility
5335 Avion Park Drive
Cleveland, Ohio 44143-2328

In the event that a product is repaired or replaced under the terms of the warranty, the warranty period of the repaired or replacement product shall be limited to the remaining portion of the original warranty period.

GLOBAL LOCATIONS

World Headquarters

STANLEY Assembly Technologies USA

5335 Avion Park Drive
Cleveland, Ohio 44143-2328, USA
Tel: +1.440.461.5500 Fax: +1.440.461.5592
Email: SATinfo@sbdinc.com

Sales and Support Americas/Asia-Pacific

STANLEY Assembly Technologies USA

2380 Meijer Drive
Troy, MI 48084, USA
Tel: +1.248.677.9709 Fax: +1.248.677.9923 Sales: 877.709.8006 Service: 877.787.7830
Email: SATinfo@sbdinc.com

France

STANLEY Engineered Fastening FRANCE

Emhart Fastening and Assembly S.N.C.
Batiment Le Monet Paris Nord 2, 9 allée des Impressionnistes
CS 59328 Villepinte, 95941 Roissy CDG Cedex, France
Tel: +33 (1) 3050 9100 Fax: +33 (1) 3051 0708
Email: Vahid.Amirzadeh@sbdinc.com

Germany

STANLEY Engineered Fastening GERMANY

Max-Eyth-Str. 1, 35394 Giessen, Germany
Tel: +49 (0) 641 405 - 728 Fax: +49 (0) 641 405 - 383
Email: Vahid.Amirzadeh@sbdinc.com

Italy

STANLEY Engineered Fastening ITALY

c/o Energipark – Building 03/Sud
Via Energy Park, 6 – 20871 Vimercate (MB) Italy
Tel: +39 (039) 9590.200 Fax: +39 (039) 9590.318
Email: Vahid.Amirzadeh@sbdinc.com

Spain

STANLEY Engineered Fastening SPAIN

Avenida de Madrid, 35
28802 Alcalá de Henares (Madrid), Spain
Tel: +34 (91) 877-0380
Email: Felix.Barba@sbdinc.com

China

STANLEY Engineered Fastening CHINA

BUILDING NO. 9, 615 FENGDENG ROAD
MALU TOWN, JIADING DISTRICT
Shanghai 201801, China
Tel: +86 21.3915.5588-5511 Fax: +86 21.3915.5555
Email: Yi.Yu@sbdinc.com

Japan

STANLEY Engineered Fastening JAPAN

Hosoda, Noyori-cho, Toyohashi-shi
Aiti (Aichi) 441-8540, Japan
Tel: +81 0532.25.1126 Fax: +81 0532.25.1120
Email: Haruhiko.Suzuki@sbdinc.com

India

STANLEY Engineered Fastening INDIA

6th Floor, Apex Towers, No 54, 2nd Main Road, R A Puram
CHENNAI – 600 028, India
Tel: +91 44 4343 7100 Fax: +91 44 4306 0768
Email: Rajesh.Patil@sbdinc.com

StanleyEngineeredFastening.com