

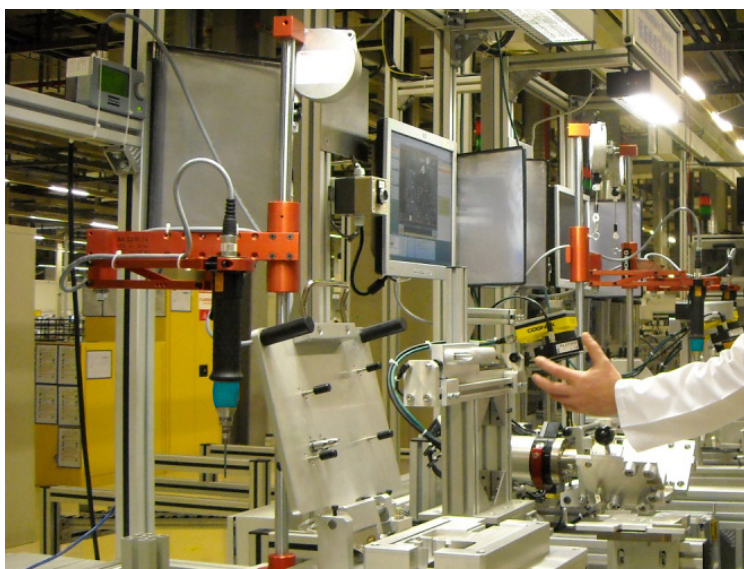

ERGONOMICS AND WORKSTATIONS



**Torque Reaction systems  
and Posi-Control systems**



## The range

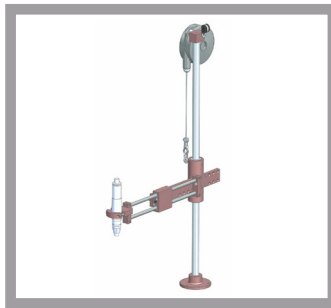

### TORQUE REACTION ARMS (p.4 to 33)

A comprehensive range of torque reaction systems to decrease employee injuries and boost your productivity.



### POSI CONTROL SYSTEM (p.34 to 47)

Error proofing and sequencing systems for zero fault assembly process. Automation devices management on your assembly line.

## Pictograms

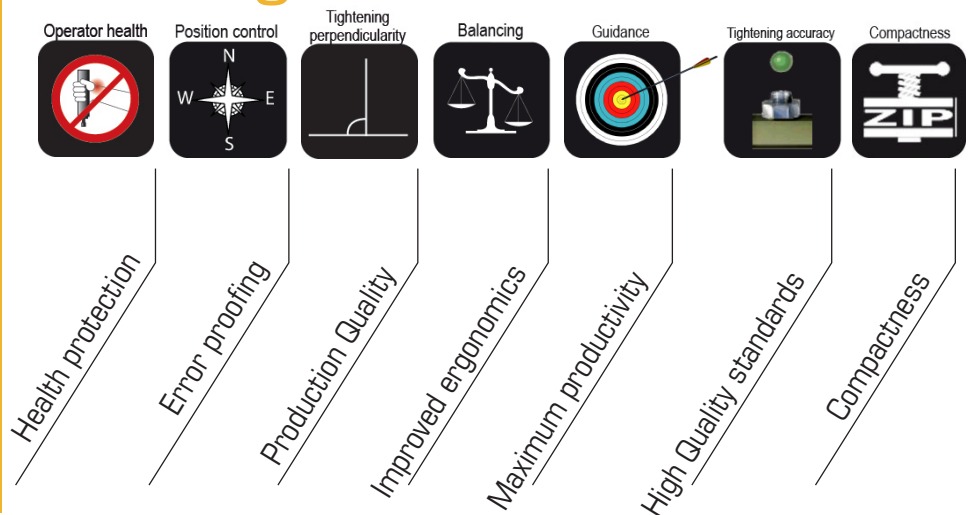

# Torque Reaction systems

The widest range of reaction arms to meet your various demanding requirements.

- Page 4 to 9 • Linear reaction arms BA Series
- Page 10 to 11 • Travelling arms BA...C Series
- Page 12 to 19 • Articulated arms BA...R Series
- Page 20 to 21 • Articulated and air balanced pantograph arm BA...G Serie
- Page 22 to 28 • Telescoping arms DMF/DMFI Series
- Page 27 • Special solutions
- Page 28 to 33 • Suspended arms SLIDER Series

**BA...**



**BA...R**



**DMF...**

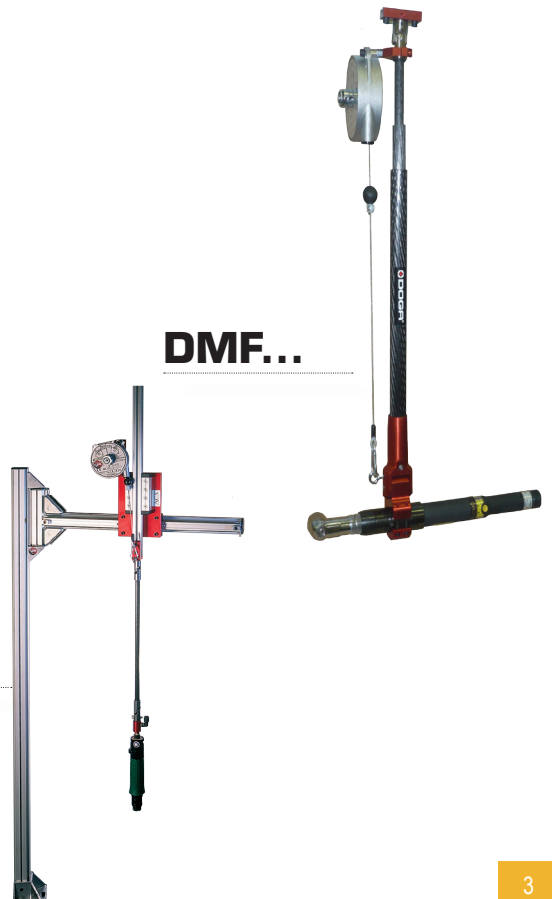

**BA...C**



**SLIDER...**



# Linear Arms

## BA Series

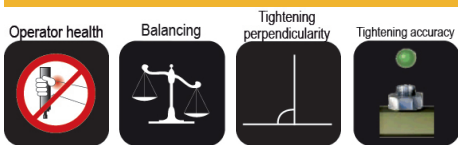

BA Series : Smooth tightening operation and perfect perpendicularity until 100 Nm.

- Erase torque reaction
- Ensure perfect perpendicularity
- Avoid illnesses
- Suppress the tiredness
- Improve the tightening quality
- Reduce the absenteeism rate
- Improve productivity

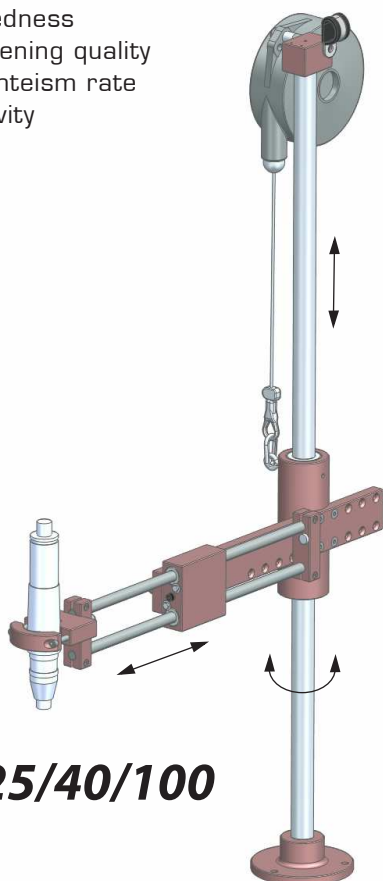

**BA 5/12/25/40/100**

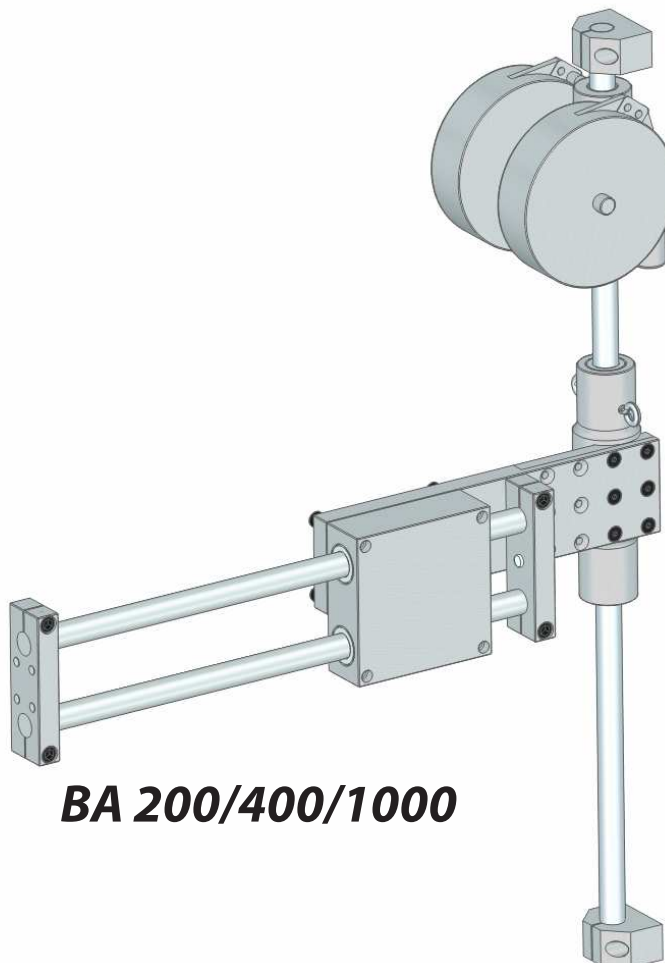

**BA 200/400/1000**

Model	Torque max (Nm)	Tool Ø (mm)	Stroke	Load max (kg)	Code
BA 5	5	25 - 42	200	0,9	4-1200085
BA 12	12	25 - 50	225	1,2	4-1201000
BA 25	25	28 - 52	250	2,2	4-1200076
BA 40	40	28 - 52	295	2,2/4*	4-1200067
BA 100	100	28 - 52	330	3,5/6*	4-1200068

\* With additional balancer - **Code : 4-1200143** (see page 6)

Model	Torque max (Nm)	Stroke	Load max (kg)	Code
BA 200	200	345	8	4-1201092
BA 400	400	400	12	4-1201093
BA 1000	1000	400	16	4-1201094

BA 200/400/1000 are delivered without clamp, floor post and non anodized.

# Linear Arms

## BA...TWIN Series

BA...TWIN model is an ideal solution when two screwdrivers are used in limited space conditions.

### BA... TWIN

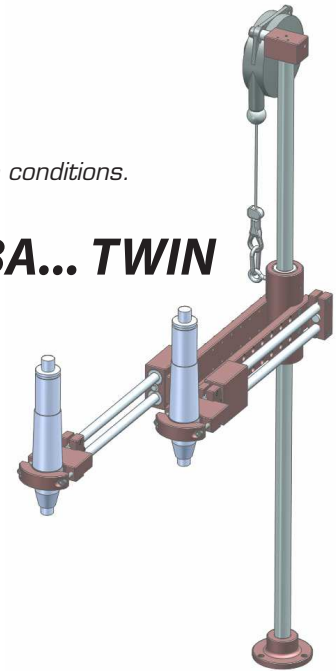

Model	Torque max (Nm)	Tool Ø (mm)	Stroke	Load max (kg)	Code
BA 12 T	12	25 - 42	225	2	4-1200823
BA 25 T	25	28 - 52	250	3	4-1200824
BA 40 T	40	28 - 52	295	4	4-1200825
BA 100 T	100	28 - 52	330	6	4-1283105

## BA Accessories

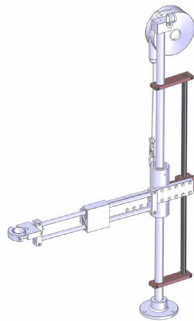

### Anti rotation clamp

For	Code
BA 5	4-1200348
BA 12 & 25	4-1200116
BA 40 & 100	4-1200117

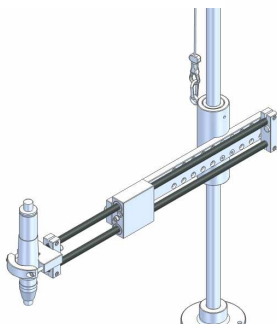

### Extended slides

For	Stroke	Code
BA 12	+ 130	4-1200120
BA 25	+ 130	4-1200720
BA 40	+ 170	4-1200122
BA 100	+ 200	4-1200123

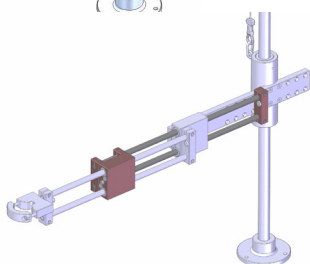

### Double slides

For	Stroke	Code
BA 12	+ 230	4-1200124
BA 25	+ 210	4-1200125
BA 40	+ 295	4-1200126
BA 100	+ 330	4-1200127

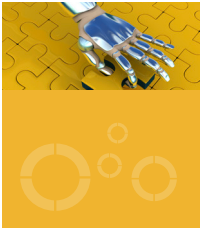

# Linear arms

## BA Accessories

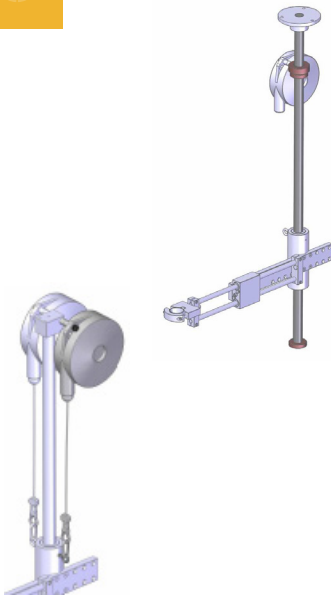

### Inverse mounting kit

For	Code
BA 5	4-1200385
BA 12 & 25	4-1200128
BA 40 & 100	4-1200129

### Additional balancing kit

For	Arm max load (Kg)	Code
BA 40	4	4-1200143
BA 100	6	4-1200143

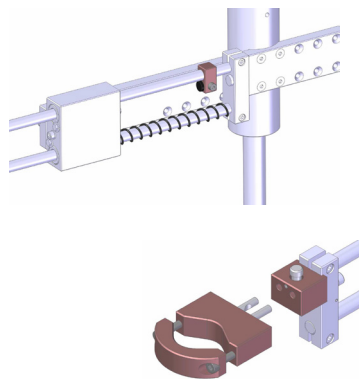

### Auto rest position kit

For	Code
BA 5 & 12	4-1200118
BA 25 & 40	4-1200119

### Quick change clamp

For	Adapter code	Clamp code
BA 12	4-1201109	4-1201003
BA 25	4-1201110	4-1200017
BA 40	4-1201111	4-1200017

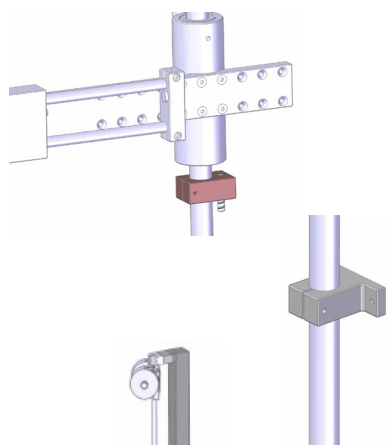

### Height adjusting clamp

For	Code
BA 5	4-1200421
BA 12 & 25	4-1200422
BA 40 & 100	4-1200423

### Pole upper clamp

For	Code
BA 12 & 25	4-1200130
BA 40 & 100	4-1200131

### Floor post

For	Code
BA 100/200/400	4-1201096
BA 1000	4-1201097

# Linear arms

## BA Accessories

### Downward Assistance Kits

Downward Assistance Kits will provide you with Extreme Comfort and productivity increase. Ideal for self-tapping applications it requires no effort from the operator. BAPER system features a built-in collect chuck that allows the system to be used at any height. Easy Push system operates only at a preset height by using a mechanical stop that is set along.

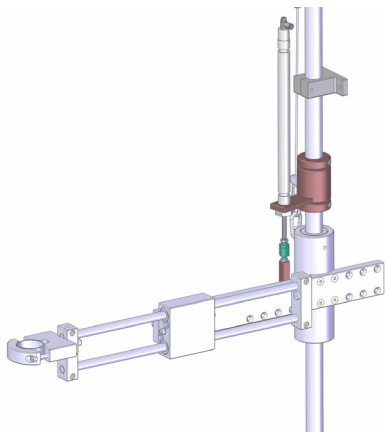

#### EASY PUSH

Model	For	Pushing force (Kg)	Stroke (mm)	Type	Code
EASY PUSH	BA 12	5	125	Pneumatic	4-1200099
EASY PUSH	BA 25	9	160	-	4-1200102
EASY PUSH	BA 40 & 100	9	200	-	4-1200103
EASY PUSH	BA 40 & 100	15	200	-	4-1200144
EASY PUSH	BA 100	25	200	-	4-1200145
EASY PUSH	BA 12	5	125	Electric	4-1200838
EASY PUSH	BA 25	9	160	-	4-1200839
EASY PUSH	BA 40 & 100	9	200	-	4-1200840
EASY PUSH	BA 40 & 100	15	200	-	4-1200841
EASY PUSH	BA 100	25	200	-	4-1200842
Easy Push Cable/GX					4-1200843
Easy Push Cable/DELVO					4-1200844
Cable without connector (for 5/9 kg pushing force)					4-1200845
Cable without connector (for 15/25 kg pushing force)					4-1200846
U3-D Interface for GX screwdrivers					6-1041888

EASY PUSH kits are delivered without cable.

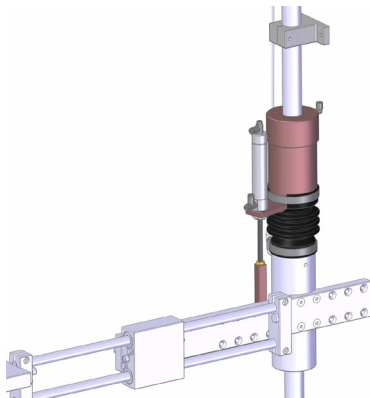

#### BAPER

Model	For	Pushing force (Kg)	Type	Code
BAPER	BA 12	5	Pneumatic	4-1200095
BAPER	BA 25	9	-	4-1200096
BAPER	BA 40 & 100	9	-	4-1200097
BAPER	BA 12	5	Electric	4-1200830
BAPER	BA 25	9	-	4-1200831
BAPER	BA 40 & 100	9	-	4-1200832
BAPER Cable/GX				4-1200833
BAPER Cable/DELVO				4-1200834
Cable without connector				4-1200835
U3-D Interface for GX screwdrivers				6-1041888

Electric BAPER kits are delivered without cable.

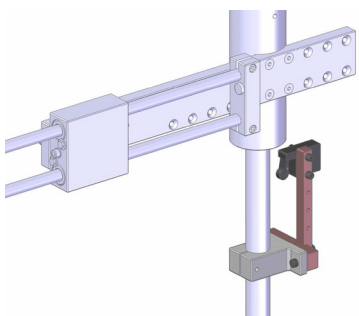

#### Safety kit

For	Code
BA 12 & 25	4-1200134
BA 40 & 100	4-1200135

The safety kit allows to avoid activation of downward assistance before powerbit gets in contact with the screw.

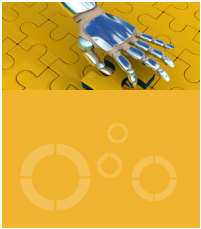

# Linear arms

BA 5 to 100 Dimensions

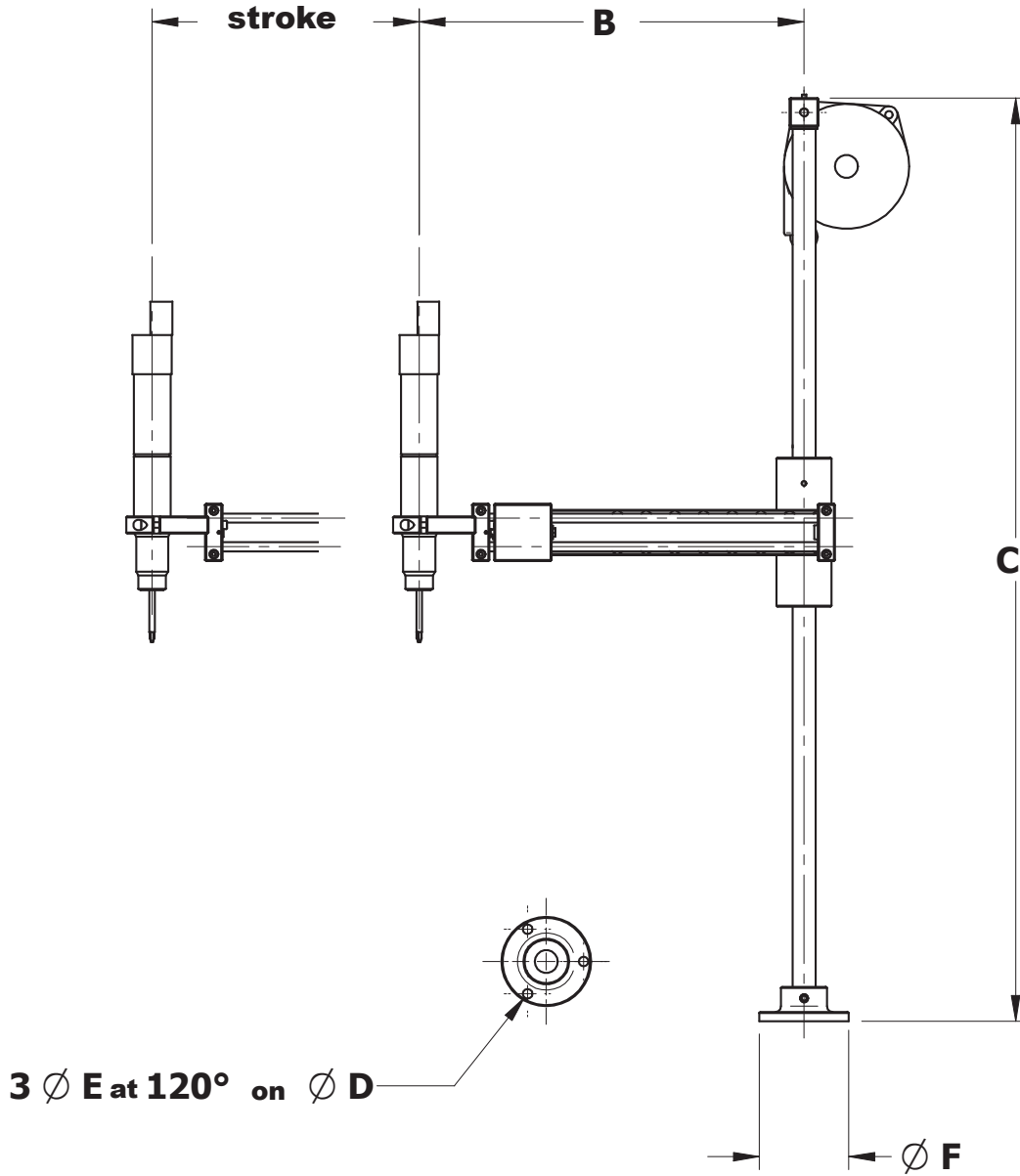

## BA Dimensions

Model	Stroke A	Min	B	Max	C	D	E	F
BA 5	200	222	302	705	65	8,5	78	
BA 12	225	186	336	805	65	8,5	78	
BA 25	250	221	396	908	65	8,5	78	
BA 40	295	260	460	1008	100	8,5	118	
BA 100	330	315	515	1008	126	10,5	148	



# Linear arms

## BA 200 / 400 Dimensions

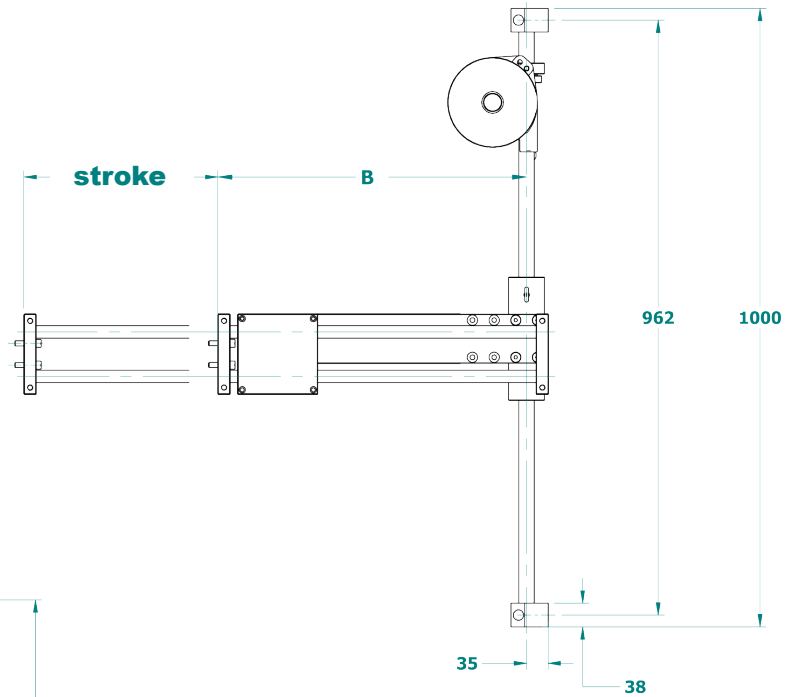

### Floor post

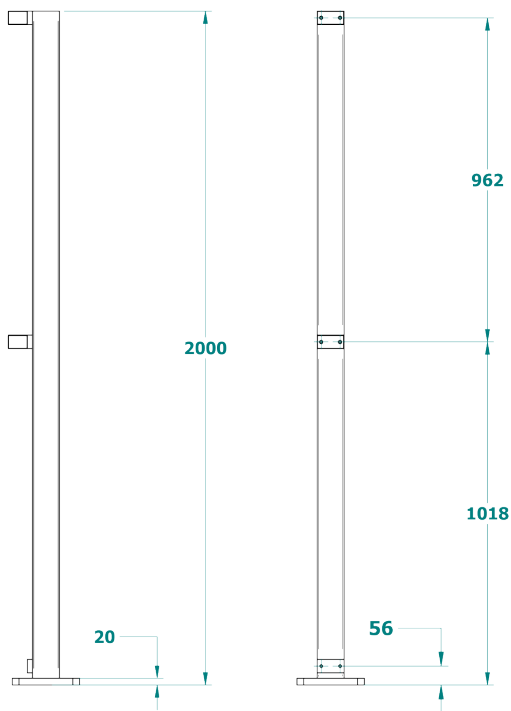

### Clamp Mounting Bracket

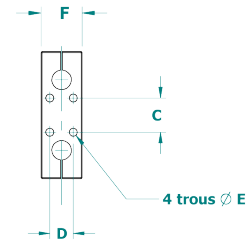

### Coupling flange

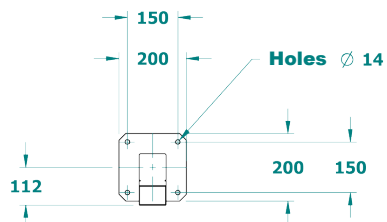
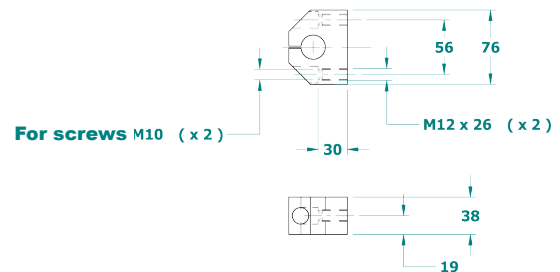

Model	Stroke A	B		C	D	E	F
		Min	Max				
BA 200	349	430	500	35	24	8,2	42
BA 400	390	326	406	40	28	12,2	52



# Travelling arms

## BA...C Series

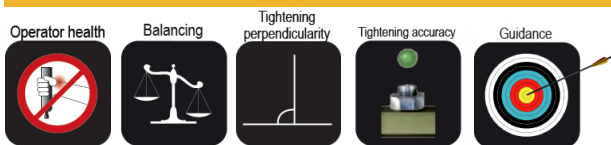

BA...C Series ideal for tightening operations on large surface or with repetitive tightening tasks.

### BA 25/60 C

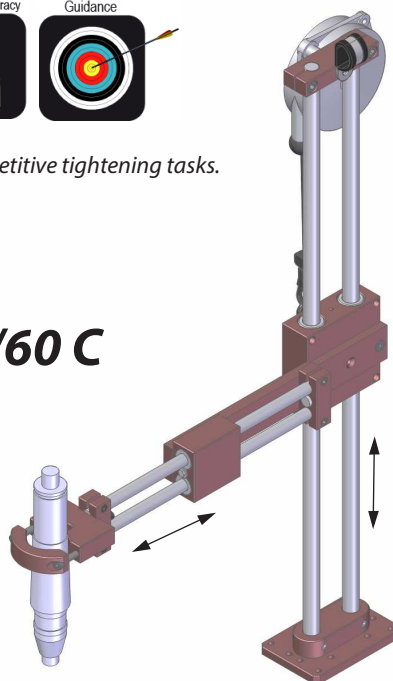

Model	Max torque (mm)	Tool Ø (mm)	Stroke (mm)	Load max (kg)	Code
BA 25 C	25	28-52	250	2,2	4-1200722
BA 60 C	60	28-52	350	3/5**	4-1200451

Delivered without horizontal rail.

Compatible accessories : extended slides, double slide, automatic rest position (ARP), quick change clamp (see page 5 and 6)

\*\* With additional balancer - Code : 4-1200143 BA 40/100

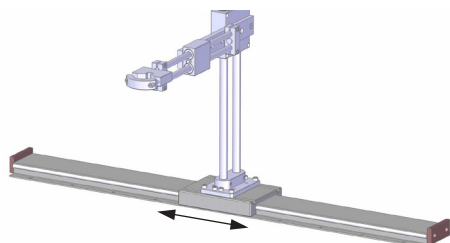

### Rails

Model	Length (mm)	Stroke (mm)	Code
Guiding rail	600	420	4-1200294
Guiding rail	1000	820	4-1200295
Guiding rail	1500	1320	4-1200296
Guiding rail	2000	1820	4-1200297

### Inverse mounting kit

For	Code
BA 25 C	4-1200811
BA 60 C	4-1200812

### Downward assistance kit

For	Pushing force (kg)	Stroke (mm)	Type	Code
EP 25 P	9	160	Pneu.	4-1200452
EP 25 E	9	160	Elect.	4-1200454
EP 60 P	9	200	Pneu.	4-1200453
EP 60 E	9	200	Elect.	4-1200455

### Safety kit

For	Code
BA 25 C	4-1200390
BA 60 C	4-1200391

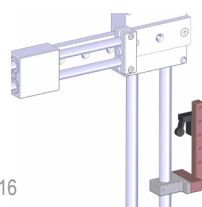
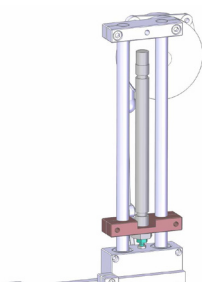

# Travelling arms

## BA...C Dimensions

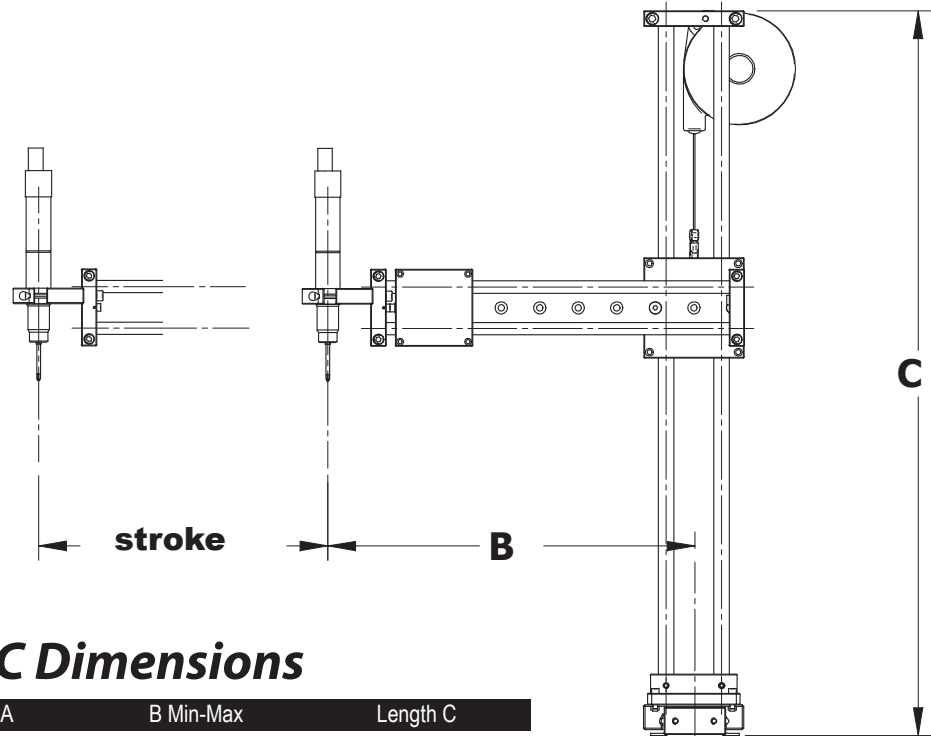

### BA 25 C / BA 60 C Dimensions

Model	Stroke A	B Min-Max	Length C
BA 25 C	205	207 - 327	737
BA 60 C	330	276 - 476	940

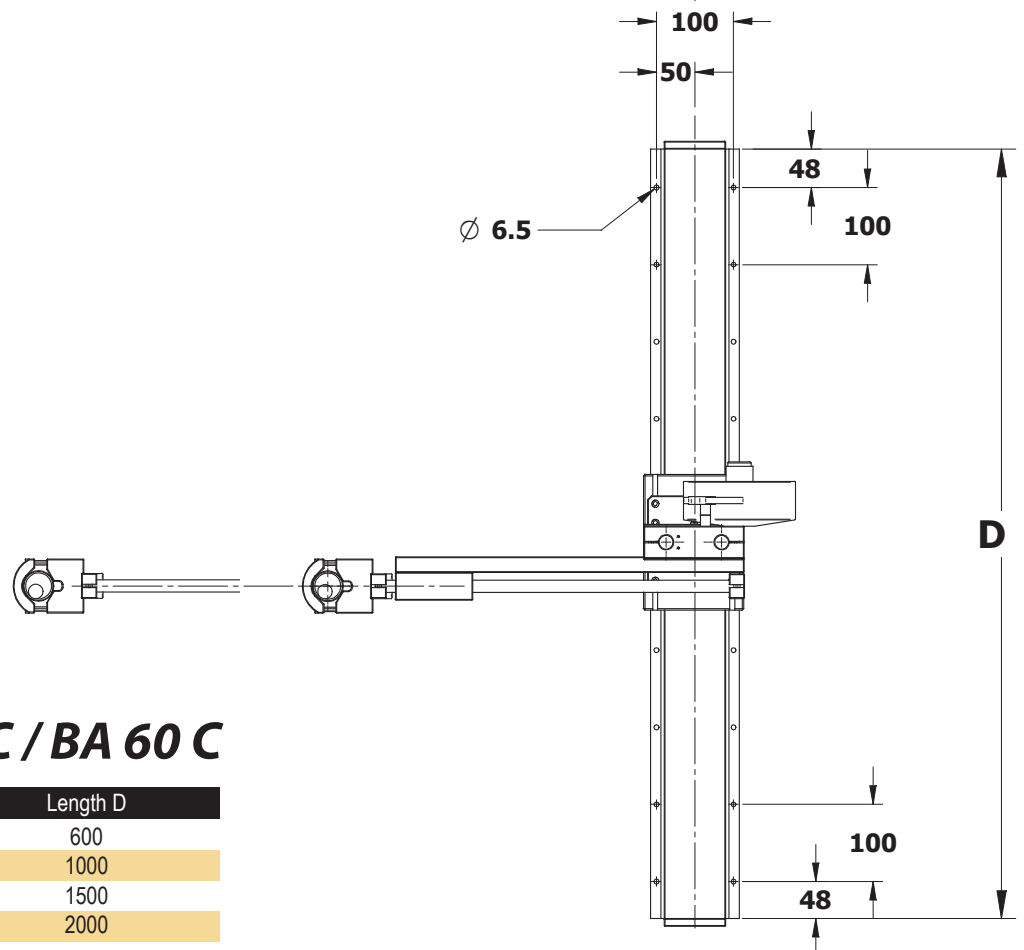

### Rails for BA 25 C / BA 60 C

Stroke	Length D
420	600
820	1000
1320	1500
1820	2000



# Articulated reaction arms

## BA...R Series

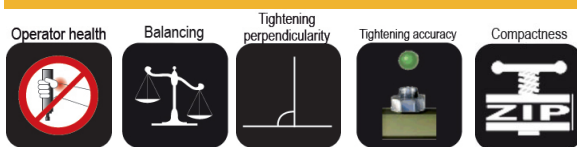

BA...R Series are equipped with a rotating articulation enabling a high working flexibility. Swivelling and folding up like a human arm, they are recommended for spaceless working places.

- Optimum ratio performance/dimensions (ideal for spaceless location)
- Economical and versatile : possibility to use on the same arm every kind of tools (straight, pistol, angle drivers) thanks to the large choice of clamps.
- Higher comfort for the operator thanks to the articulated arm (less movement inertia and better positioning accuracy).

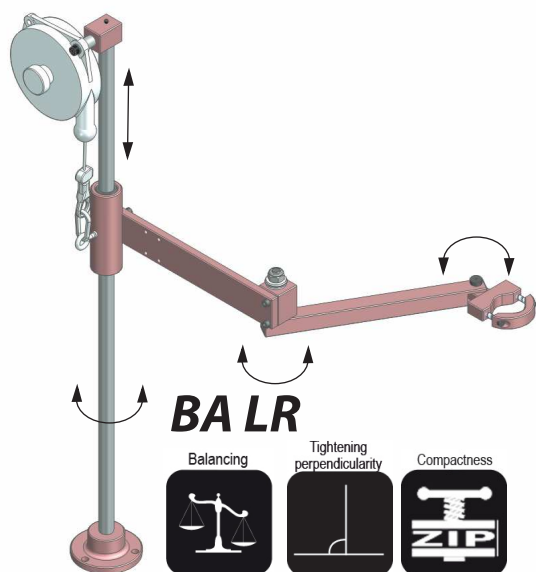

**BA LR**

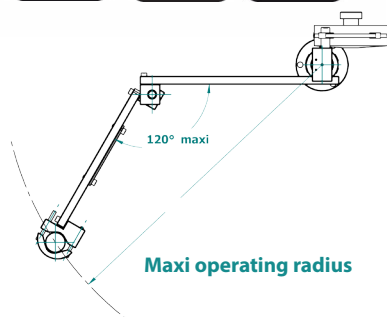
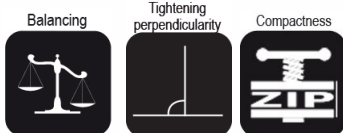

## BA 5/12/25/40/100 R

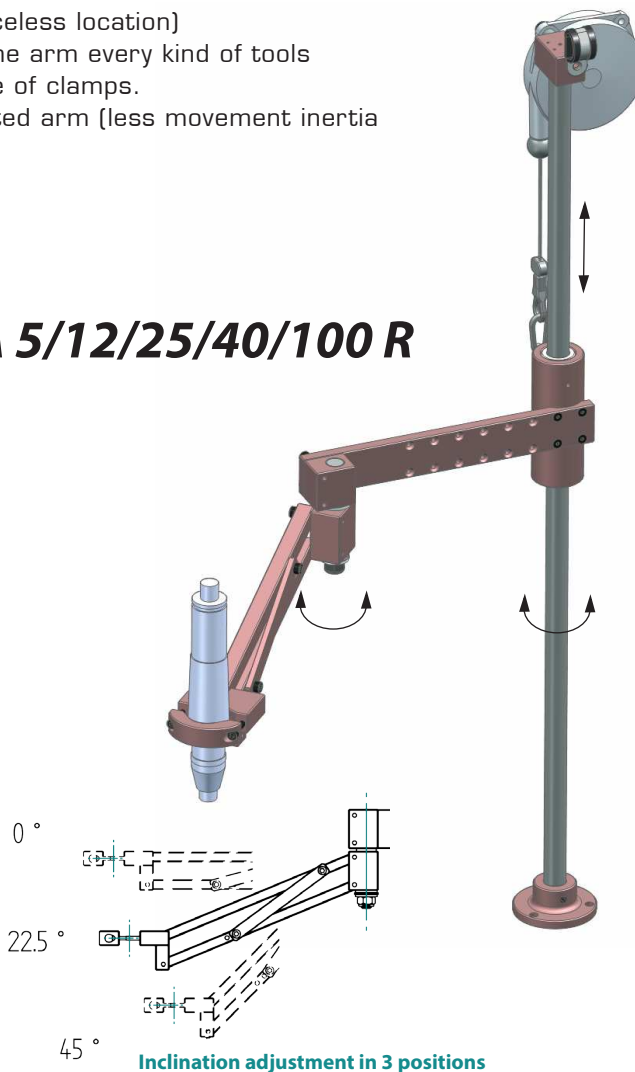

Inclination adjustment in 3 positions

Model	Max torque (Nm)	Tool Ø (mm)	Max load (kg)	Max radius (mm)	Code
BA LR	-	25 - 42	0,9	450	4-1200826
BA 5 R	5	25 - 42	0,9	420	4-1200098
BA 12 R	12	25 - 50	1,2	450	4-1201001
BA 12 R	12	25 - 50	1,2	600	4-1201002
BA 25 R	25	28 - 52	2,2	445	4-1200070
BA 25 R	25	28 - 52	2,2	600	4-1200274
BA 25 R	25	28 - 52	2,2	800	4-1200275
BA 40 R	40	28 - 52	2,2 - 4*	630	4-1200071
BA 40 R	40	28 - 52	2,2 - 4*	800	4-1200276
BA 40 R	40	28 - 52	2,2	1000	4-1200277
BA 100 R	100	28 - 52	3,5 - 6*	715	4-1200072
BA 100 R	100	28 - 52	3,5 - 6*	900	4-1200278
BA 100 R	100	28 - 52	3,5	1100	4-1200279

\* With additional balancer - Code : 4-1200143.

Delivered with standard clamp for straight tool.

# Articulated reaction arms

## BA...R Accessories

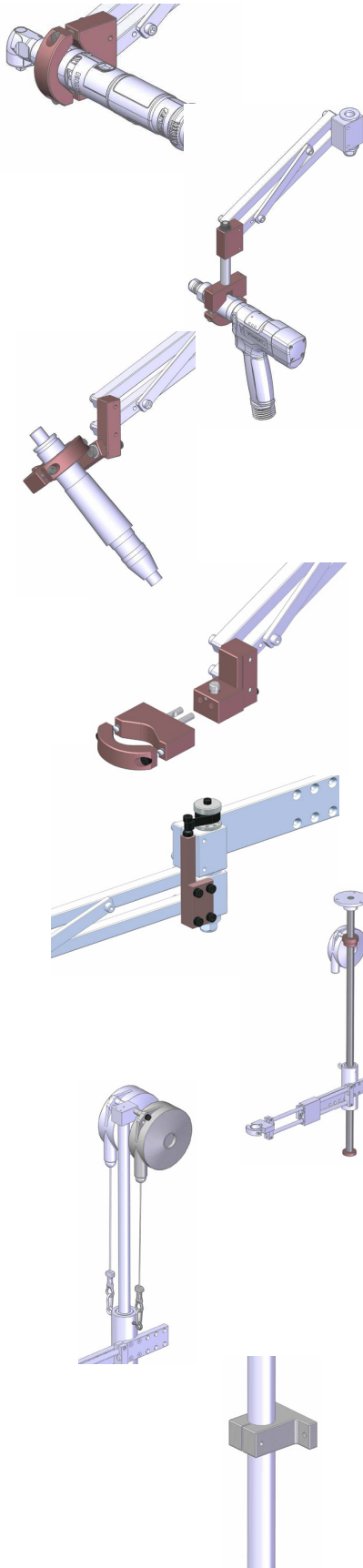

### Clamp for angle nutrunner

For	Tool Ø (mm)	Code
BA 12 R	25 - 42	4-120089
BA 25 & 40 R	28 - 52	4-120090
BA 100 R	28 - 52	4-120091

### Clamp for pistol tool

For	Tool Ø (mm)	Code
BA 12 R	25 - 42	4-120087
BA 25 & 40 R	28 - 52	4-120088

### 2 axis clamp

For	Tool Ø (mm)	Code
BA 12 R	25 - 42	4-120093
BA 25 & 40 R	28 - 52	4-120094

### Quick change clamp

For	Adaptater code	Code
BA 12 R	4-1200847	4-1201003
BA 25 R	4-1200848	4-1200017
BA 40 R	4-1200848	4-1200017

### Auto rest spring

For	Code
BA 5/12 R	4-1200849
BA 25 R	4-1200850
BA 40 R	4-1200851

### Inverse mounting kit

For	Code
BA 5 R	4-1200385
BA 12 & 25 R	4-1200128
BA 40 & 100 R	4-1200129

### Additional balancing kit

For	Arm max load (kg)	Code
BA 40 R	4	4-1200143
BA 100 R	6	4-1200143

### Pole upper clamp

For	Interface (mm)	Code
BA 12 & 25 R	2 Ø 4,3 at 45 mm from pole axis	4-1200130
BA 40 & 100 R	2 Ø 5,3 at 60 mm from pole axis	4-1200131



# Articulated reaction arms

## BA...R Accessories

### Downward assistance kits

Downward assistance kits will provide you with extreme comfort and productivity increase. Ideal for self-tapping applications it requires no effort from the operator. BAPER system features a built-in collet check that allows the system to be used at any height. Easy push system operates only at a preset height by using a mechanical stop that is set along the pole.

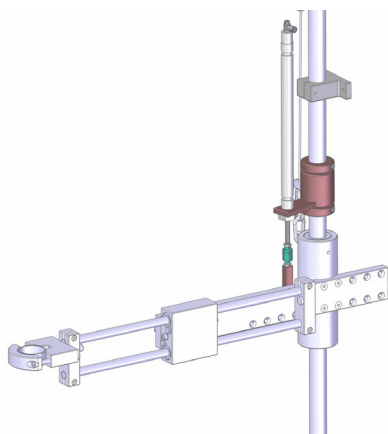

#### EASY PUSH

Model	For	Pushing force (kg)	Stroke (mm)	Type	Code
EASY PUSH	BA 12 R	5	125	Pneumatic	4-1200099
EASY PUSH	BA 25 R	9	160	-	4-1200102
EASY PUSH	BA 40 & 100 R	9	200	-	4-1200103
EASY PUSH	BA 12 R	5	125	Electric	4-1200838
EASY PUSH	BA 25 R	9	160	-	4-1200839
EASY PUSH	BA 40 & 100 R	9	200	-	4-1200840
Easy Push Cable/GX					4-1200843
Easy Push Cable/DELVO					4-1200844
Cable without connector					4-1200845
U3-D Interface for GX screwdrivers					6-1041888

EASY PUSH kits are delivered without cable.

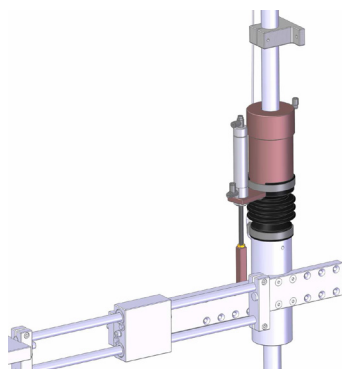

#### BAPER

Model	For	Pushing force (kg)	Type	Code	
BAPER	BA 12 R	5	Pneumatic	4-1200095	
BAPER	BA 25 R	8	-	4-1200096	
BAPER	BA 40 & 100 R	8	-	4-1200097	
BAPER	BA 12 R	5	Electric	4-1200830	
BAPER	BA 25 R	8	-	4-1200831	
BAPER	BA 40 & 100 R	8	-	4-1200832	
BAPER Cable/GX					4-1200833
BAPER Cable/DELVO					4-1200834
Cable without connector					4-1200835
U3-D Interface for GX screwdrivers					6-1041888

Electric BAPER kits are delivered without cable.

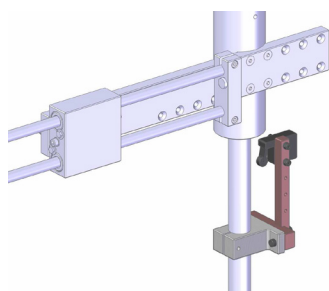

#### Safety kit

Model	For	Code
Safety kit	BA 12 & 25 R	4-1200134
Safety kit	BA 40 & 100 R	4-1200135

The safety kit allows to avoid activation of downward assistance before powerbit gets in contact with the screw.

# Articulated reaction arms

## BA...R high torque



**BA 180 R**



**BA 200/500 R**



**BA 180 R**

Model	Max. torque (Nm)	Max load (kg)	Max radius (mm)	Code
BA 180 R / 1200	180	6	1200	4-1201095
BA 180 R / 1500	180	4	1500	4-1200827

Delivered without tool clamp, floor post and not anodized.



**BA 200 R / 500 R**

Model	Max. torque (Nm)	Max load (kg)	Max radius (mm)	Code
BA 200 R	200	20	2000	4-1200828
BA 500 R	500	40	2000	4-1200829
BA 500 R/2500	500	30	2500	4-1283106
BA 500 R/3000	500	40	3000	4-1283107

Delivered without tool clamp.  
Higher capacity on request.



# Articulated reaction arms

## BA...R high torque accessories

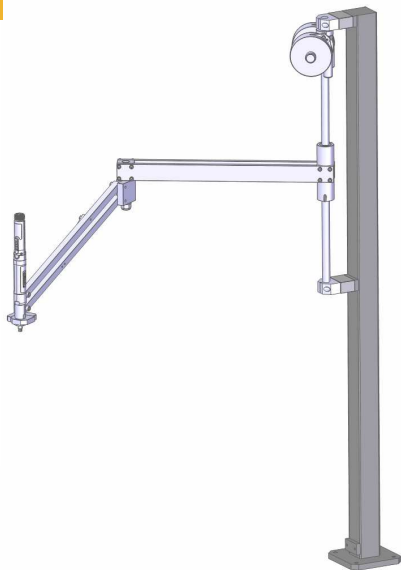

### **BA 180 R equipped with floor post (optional)**

The BA 180 R can be mounted directly on your structure or on an optional post to split on the floor.

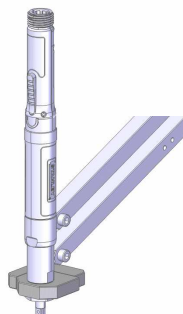

### **Arm/power tools interface for straight tools and for angular tool with BA 180 R**

**Code : 4-1201105.**

*Note : please precise the screwdriver type.*



### **BA 100/200/400 and 100/180 R Floor Post**

**Code : 4-1201096.**

### **Pneumatic break with rotating clamp (option)**



### **BA 200R/500R**

Numerous options are available to meet your process requirement :

- pneumatic break
- rotating clamp
- controller base plate
- remote start handle



# Articulated reaction arms

## BA...R 5 to 100 Dimensions

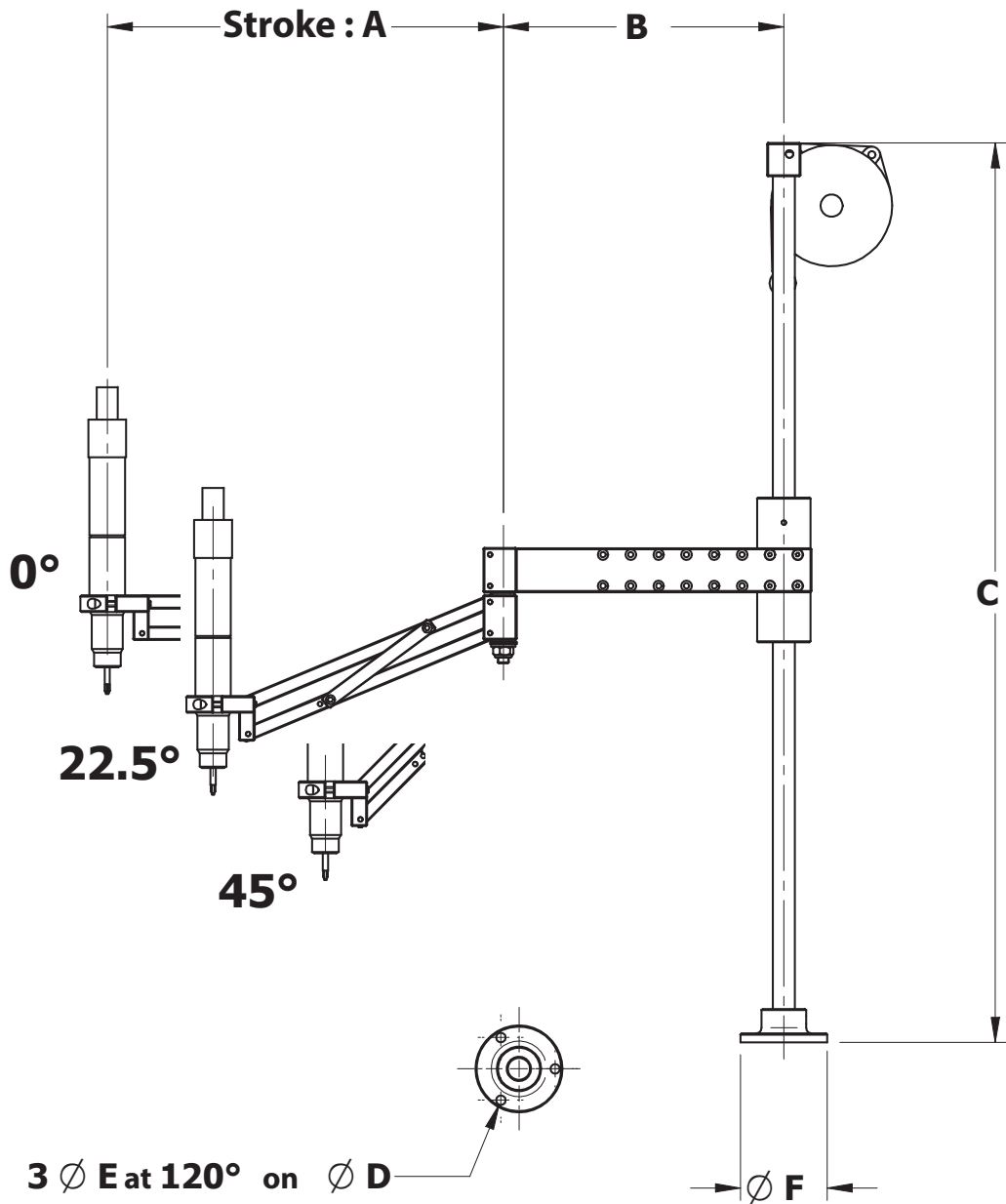

### BA...R dimensions

Model	A 0° (mm)	A 22,5° (mm)	A 45° (mm)	Min	B Max (mm)	C (mm)	Operating radius at 22,5° (mm)
BA 5 R	259	243	192	132	212	705	420
BA 12 R	279	261	209	102	252	808	450
BA 12 R / 600	332	310	247	332	357	808	600
BA 25 R	296	278	227	95	245	908	460
BA 25 R / 600	358	336	271	305	330	908	600
BA 25 R / 800	483	452	360	417	442	908	800
BA 40 R	414	387,5	310,5	150	350	1008	650
BA 40 R / 800	503	470	374	415	415	1008	800
BA 40 R / 1000	640	597	471	520	520	1008	1000
BA 100 R	462	433	351	205	405	1008	730
BA 100 R / 900	564	528	425	470	520	1008	900
BA 100 R / 1100	694	648	517	585	635	1008	1100



# Articulated reaction arms

## BA 180 R Dimensions

### BA 180 R

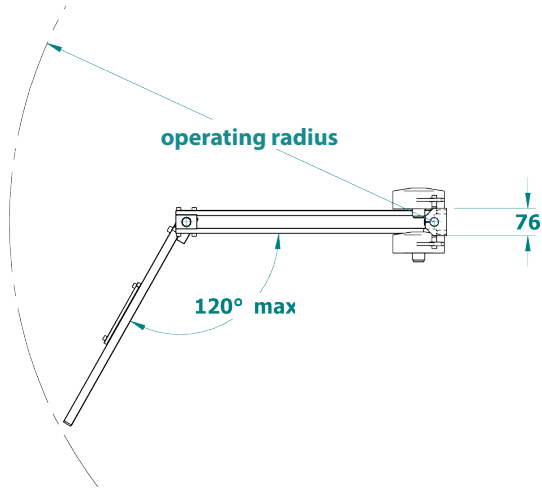

### Coupling flange

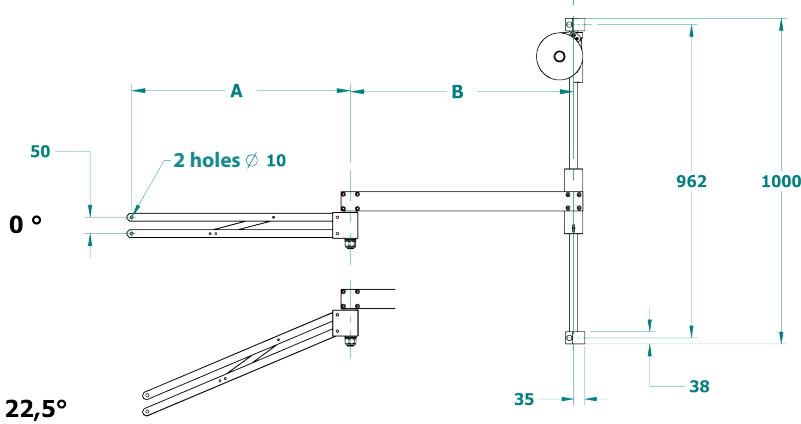
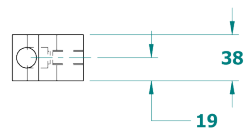
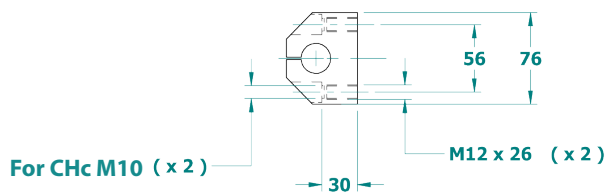

### Floor post

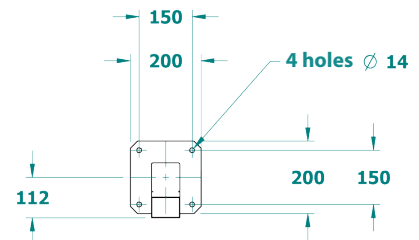
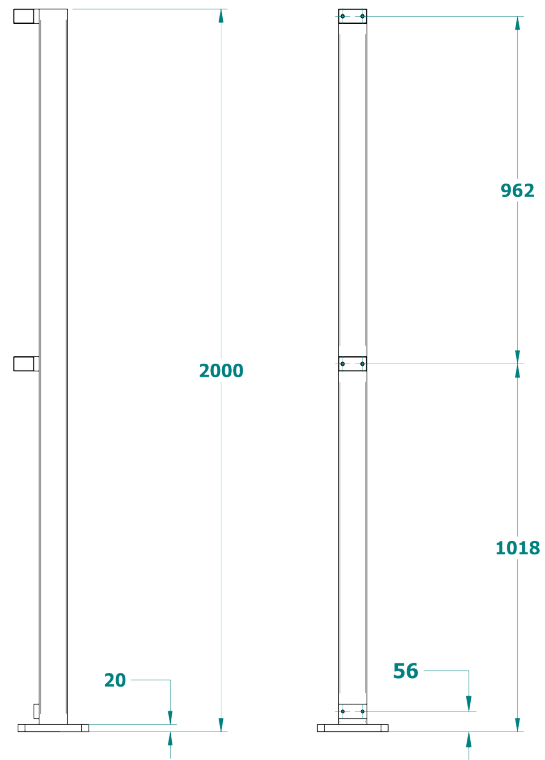

Type	A (0°)	A (22,5°)	B	C	Operating radius
BA 180 R/1200	686	637	700	2000	1200
BA 180 R/1500	820	760	855	2000	1500

# Articulated reaction arms

## BA 200 & 500 R Dimensions

### BA 200/500 R

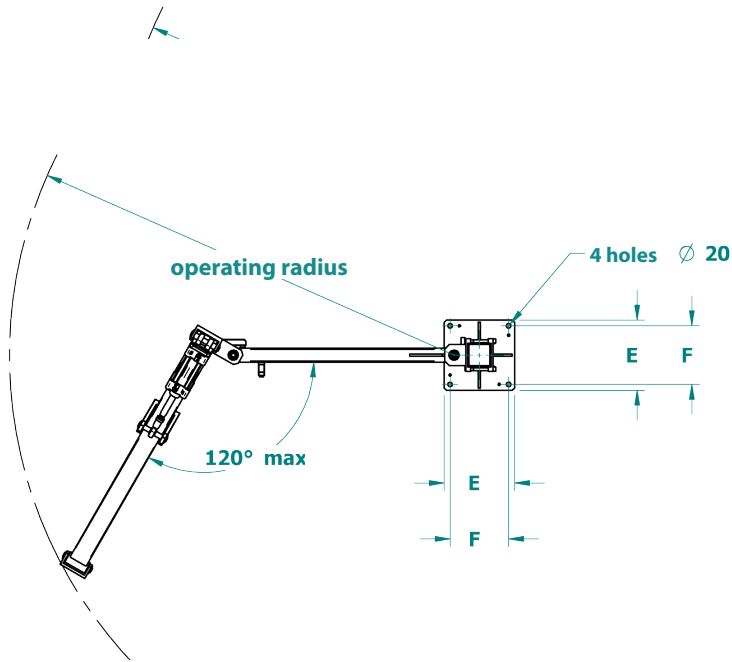
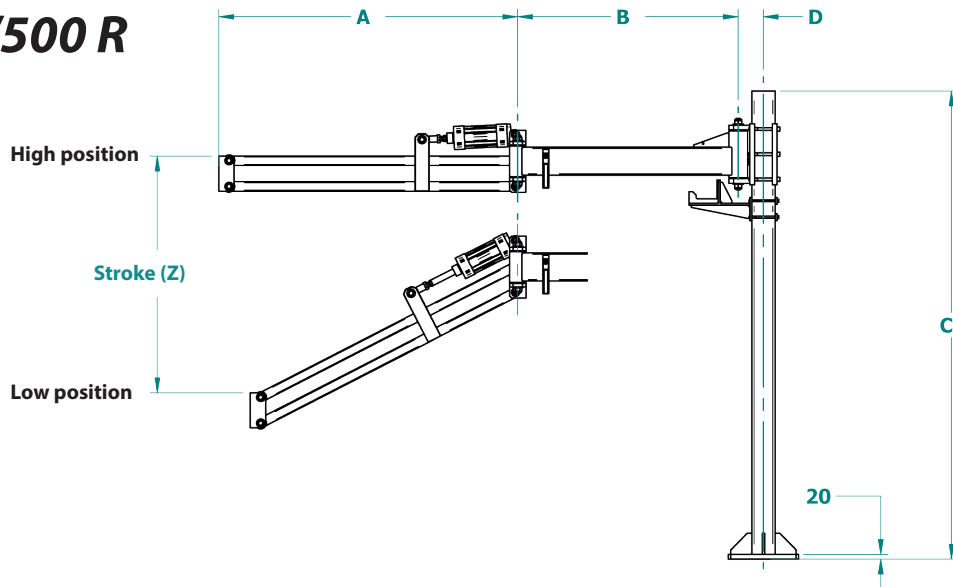

### Tool clamp mounting bracket

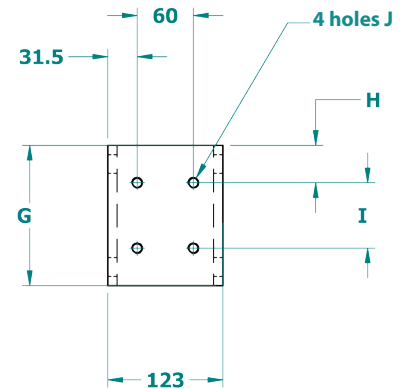

Model	A (high position)	Z (Stroke)	B	C	D	E	F	G	H	I	J	K	Operating radius
BA 200 R	1278	559	943	2000	108	300	250	150	40	70	M12	108	1900
BA 500 R	1278	559	943	2000	118	400	350	170	45	80	M16	118	1900
BA 500 R/2500	1478	650	1293	2000	118	400	350	170	45	80	M16	118	2400
BA 500 R/3000	1978	1100	1560	2000	118	500	450	170	45	100	M16	118	2900

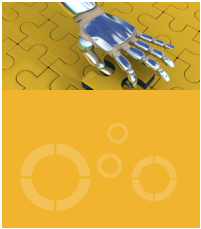

# Articulated and air balanced pantograph

## BA...G Series

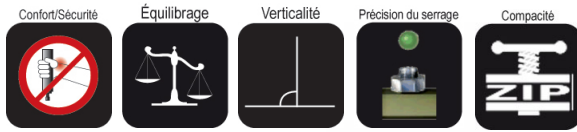

Inspired from the BA...R Series, the BA...G Series provides you even more flexibility and confort thanks to the air balanced design.

- Softly air balanced !
- Quick and quiet !

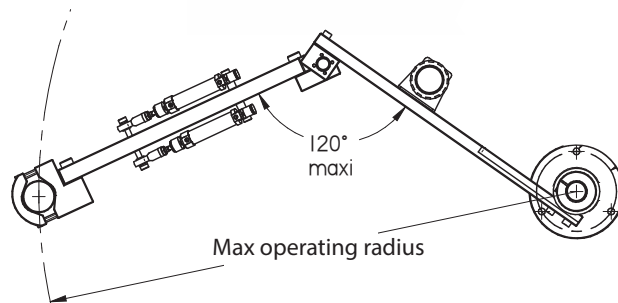

Model	Torque Max (Nm)	Tool Ø (mm)	Vertical Stroke (mm)	Maxi load (Kg)	Max radius (mm)	Code
BA10 G	10	25 - 50	170	1	470	4-1201013
BA10 G/600	10	25 - 50	170	1	600	4-1201014
BA30 G	30	28 - 52	220	2	670	4-1201015
BA30 G/800	30	28 - 52	220	2	800	4-1201016

# Articulated and air balanced pantograph

## BA...G Series

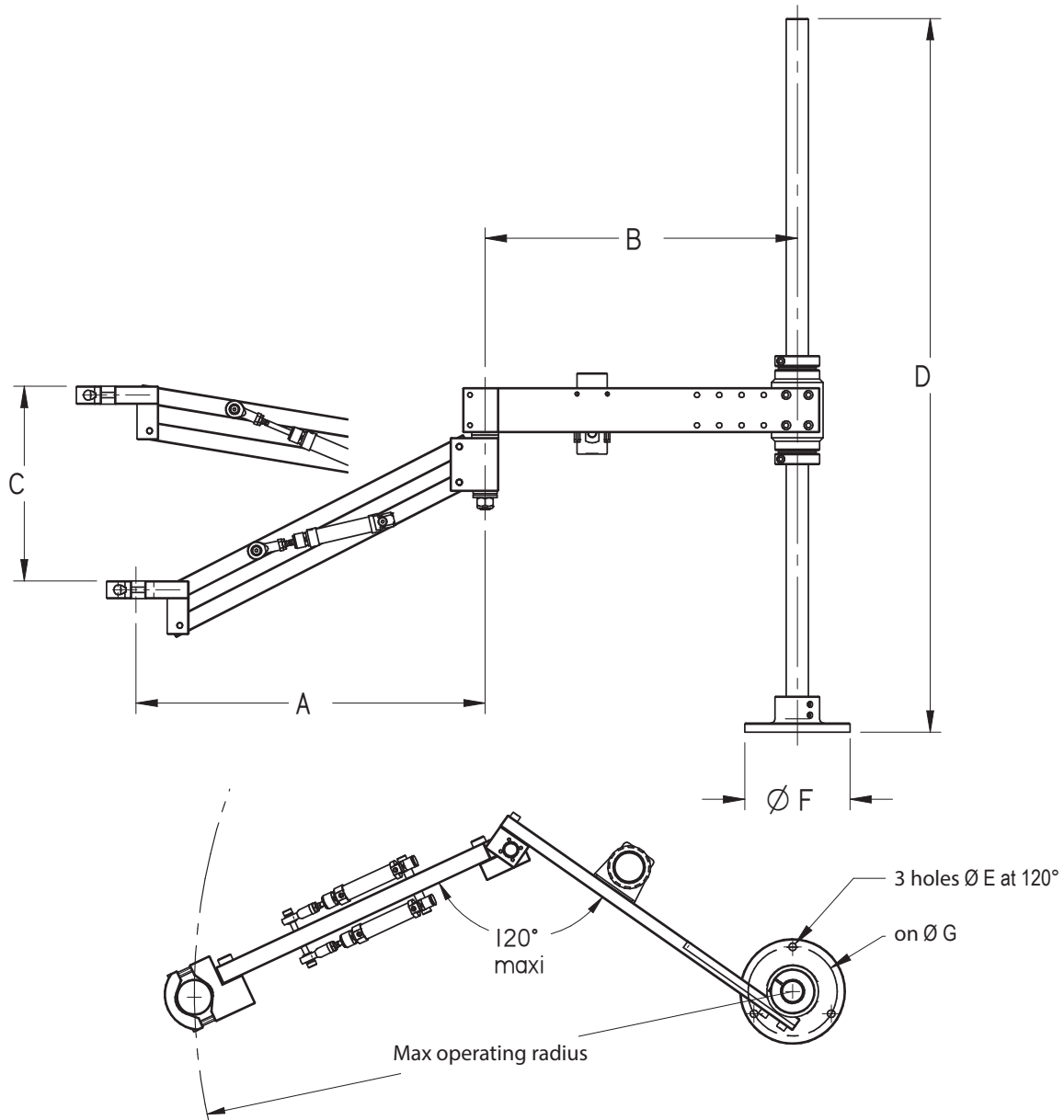

Model	A (down position)	B mini	B maxi	C Vertical Stroke	D	Dim. E	Dim. F	Dim. G	Max radius (mm)
BA10 G	260	202	252	170	600	8,5	78	65	470
BA10 G/600	260	357	407	170	600	8,5	78	65	600
BA30 G	391	250	350	218	800	8,5	118	100	670
BA30 G/800	391	405	505	218	800	8,5	118	100	800

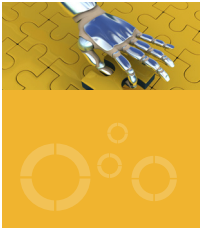

# Carbon telescoping arms

## DMF/DMFI Series

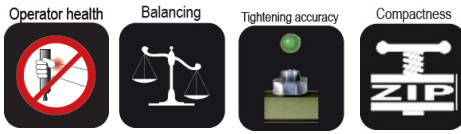

*DMF Series : Erase your torque reaction until 300 Nm.*

- **Comfort** : Easy to install on moving assembly line (mountable on existing standard rail). Require little space and doesn't disrupt flow production. Erase torque reaction of power tools.
- **Economy** : Maintenance free thanks to the carbon fiber (no greasing). Long last of living thanks to the durable carbon fiber.
- **Productivity** : Easy and quick operator handling thanks to the light weight carbon fiber.

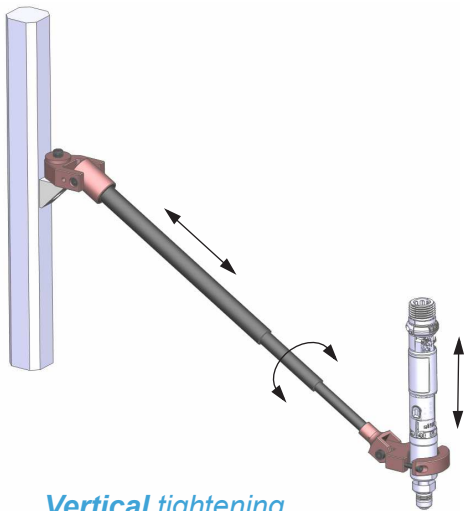

*Vertical tightening*

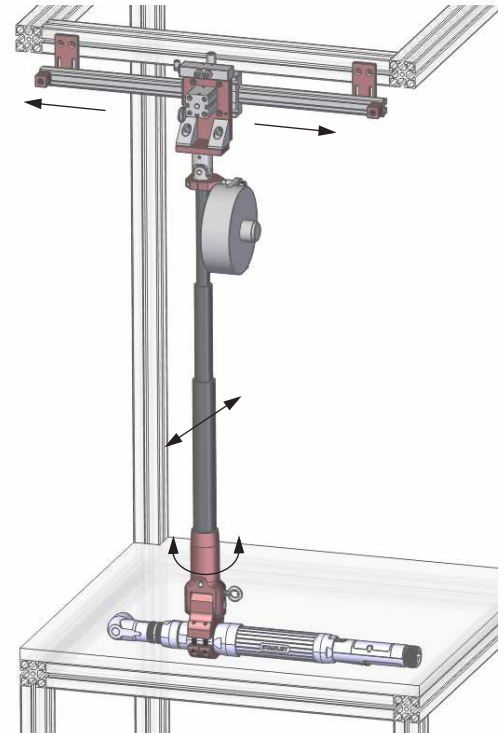

*Frontal tightening*

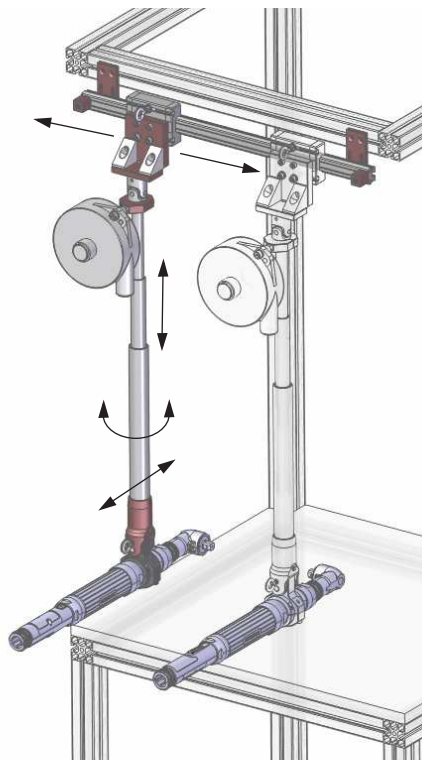

*Side tightening*

# Articulated pantograph

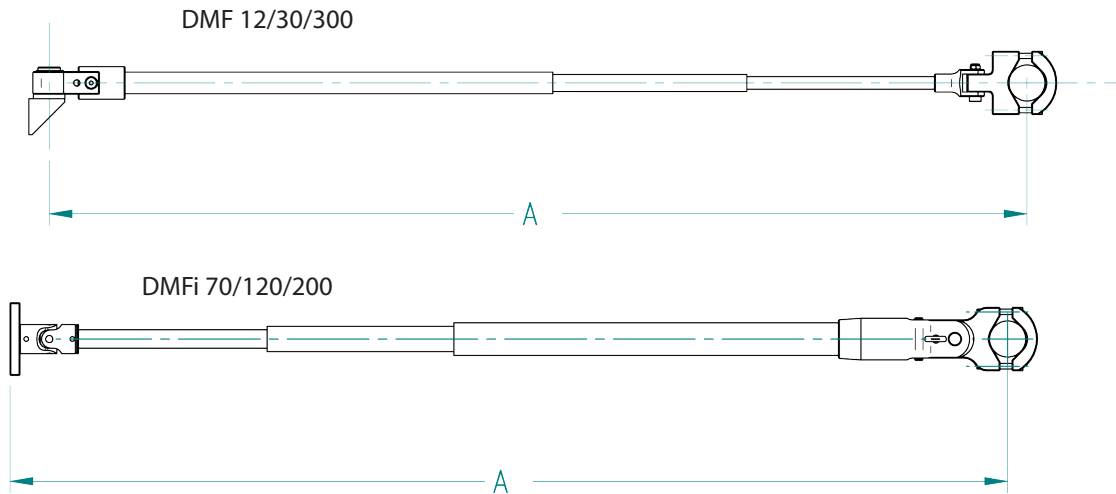

## Standard stroke

Model	Max torque (Nm)	Standard clamp	Tool Ø (mm)	A min (mm)	A max (mm)	Code	
						Without clamp	With clamp
DMF 5/950	5	P1	25 - 42	460	950		4-1200445
DMF 12/950	12	P1	25 - 50	460	950		4-1201004
DMF 12/1500	12	P1	25 - 50	650	1500		4-1201005
DMF 12/2000	12	P1	25 - 50	820	2000		4-1201006
DMF 30/960	30	P1	28 - 52	475	960	4-1244000	4-1200074
DMF 30/1500	30	P1	28 - 52	656	1500	4-1244001	4-1200282
DMF 30/2000	30	P1	28 - 52	823	2000	4-1244002	4-1200283
DMF 30/2500	30	P1	28 - 52	993	2500	4-1244003	4-1200284
DMF 30/3000	30	P1	28 - 52	1321	3000	4-1200813	4-1200818
DMFi 70/1500	70	P2	35 - 52	667	1500	4-1244004	4-1244020
DMFi 70/2000	70	P2	35 - 52	833	2000	4-1244005	4-1244021
DMFi 70/2500	70	P2	35 - 52	1000	2500	4-1244006	4-1244022
DMFi 70/3000	70	P2	35 - 52	1330	3000	4-1200814	4-1200819
DMFi 120/1500	120	P2	35 - 52	691	1500	4-1244007	4-1244023
DMFi 120/2000	120	P2	35 - 52	857	2000	4-1244008	4-1244024
DMFi 120/2500	120	P2	35 - 52	1023	2500	4-1244009	4-1244025
DMFi 120/3000	120	P2	35 - 52	1347	3000	4-1200815	4-1200820
DMFi 200/1500	200	P2	Maxi 63	920	1500	4-1244050	4-1244026
DMFi 200/2000	200	P2	Maxi 63	1170	2000	4-1244051	4-1244027
DMFi 200/2500	200	P2	Maxi 63	1420	2500	4-1244052	4-1244028
DMFi 200/3000	200	P2	Maxi 63	1720	3000	4-1200816	4-1200821
DMF 300/1500	300	P2	Maxi 73	970	1500	4-1244053	4-1244029
DMF 300/2000	300	P2	Maxi 73	1220	2000	4-1244054	4-1244030
DMF 300/2500	300	P2	Maxi 73	1470	2500	4-1244055	4-1244031
DMF 300/3000	300	P2	Maxi 73	1800	3000	4-1200817	4-1200822

Other dimensions on request (max length 4 meters).  
Torque up to 600 Nm is available on request.

## Long stroke (LS)

Model	Max torque (Nm)	Standard clamp	Tool Ø (mm)	A min (mm)	A max (mm)	Code	
						Without clamp	With clamp
DMF 30/1500 LS	30	P1	28 - 52	555	1500	4-1200852	4-1200855
DMF 30/2000 LS	30	P1	28 - 52	680	2000	4-1200853	4-1200856
DMF 30/2500 LS	30	P1	28 - 52	805	2500	4-1200854	4-1200857
DMFi 100/1500 LS	100	P2	35 - 52	592	1500	4-1201213	4-1201221
DMFi 100/2000 LS	100	P2	35 - 52	717	2000	4-1201214	4-1201222
DMFi 100/2500 LS	100	P2	35 - 52	842	2500	4-1201215	4-1201223
DMFi 200/1500 LS	200	P2	Maxi 63	728	1500	4-1201216	4-1201224
DMFi 200/2000 LS	200	P2	Maxi 63	894	2000	4-1201217	4-1201225
DMFi 200/2500 LS	200	P2	Maxi 63	1060	2500	4-1201220	4-1201226



# Vertical tightening

## DMF/DMFI Series

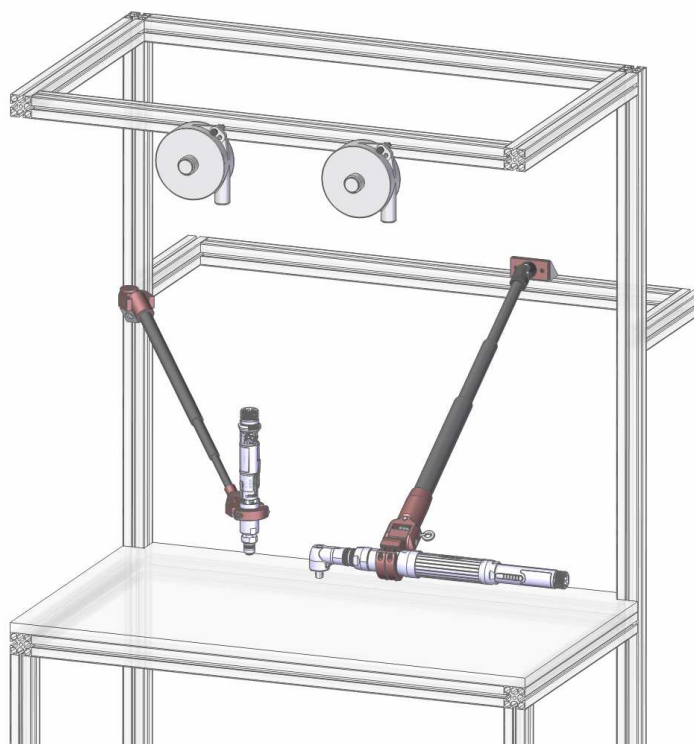

### P1 clamp

For	Clamping	Code
DMF12	Clamp 25/50	Standard
DMF30	Clamp 28/52	Standard
DMFi 70	Mounting plate interface	4-1244032
DMFi 120/200	Mounting plate interface	4-1244033

### P2 clamp

For	Capacity	Code
DMF30	28/52	4-1200300
DMFi70	35/52	Standard
DMFi120/200	35/52	Standard
DMFi200	63	Standard
DMF300	73	Standard

### Quick release clamp

For	Type	Code
DMF12	P1	4-1201003
DMF30	P1	4-1200017
DMFi 70	P2	4-1283102
DMFi 120/200	P2	4-1283103

### Quick release interface

For	Code
DMF12	4-1200470
DMF30	4-1200471
DMF70	4-1283100
DMF120/200	4-1283101

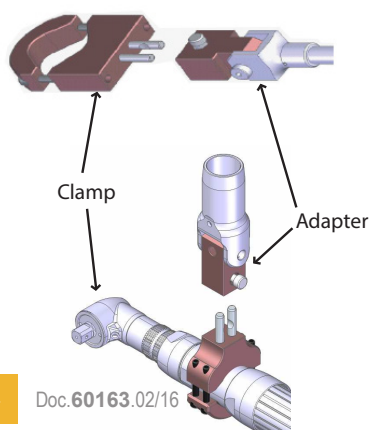
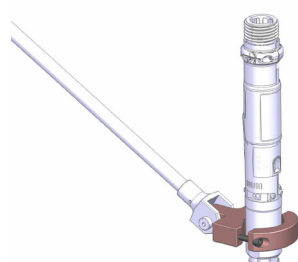



# Frontal tightening

## DMF/DMFI Series

### Fixed mounting

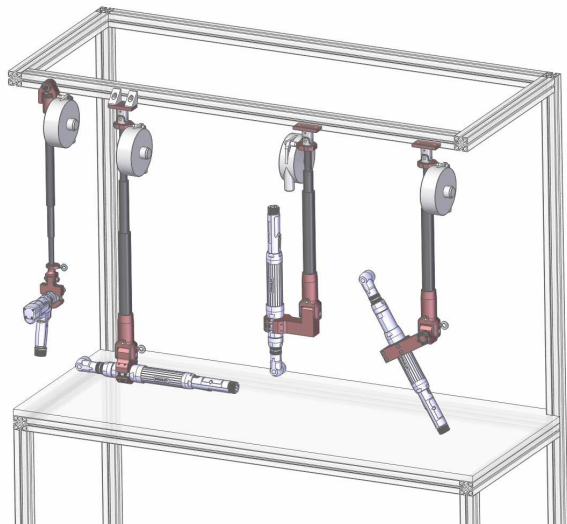

### Mounting on rail with locker

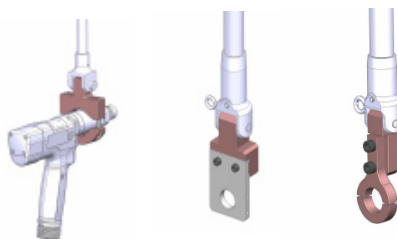
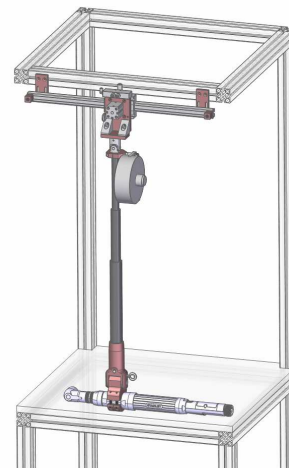

### P1 clamp

For	Clamping	Code
DMF12	Clamp 25/50	Standard
DMF30	Clamp 28/52	Standard
DMFi70	Mounting plate interface	4-1244032
DMFi120/200	Mounting plate interface	4-1244033
DMF300	Mounting plate interface	On request

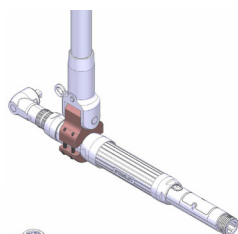

### P2 clamp

For	Tool Ø	Code
DMF30	28/52	4-1200300
DMFi70	35/52	Standard
DMFi120/200	35/52	Standard
DMFi200	Max 63	Standard
DMF300	Max 73	Standard

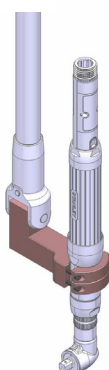

### P4 clamp

For	Tool Ø	Code
DMF30	28/52	4-1200302
DMFi70	35/52	4-1244015
DMFi120/200	35/52	4-1244016
DMFi200	Max 63	4-1244058
DMF300	Max 73	4-1244059

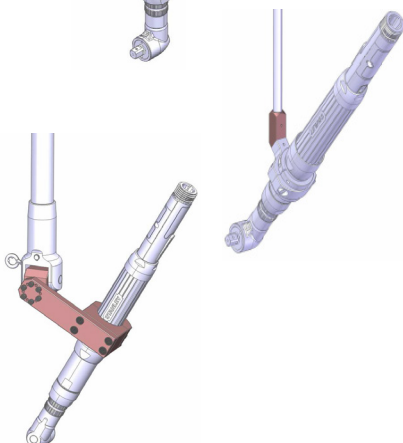

### Tilt interface

For	Tool Ø	Code
Interface/DMF30 (for all clamp types)	-	30° 45° 4-1201140 4-1201141

### Swivel clamp

For	Tool Ø	Code
DMFi70 P2/P4	35/52	4-1201137
DMFi120/200 P2/P4	35/52	4-1201138
DMFi200 P2/P4	Max 63	4-1201139
DMF300	Max 73	On request



# Side tightening

## DMF/DMFI Series

### Fixed mounting

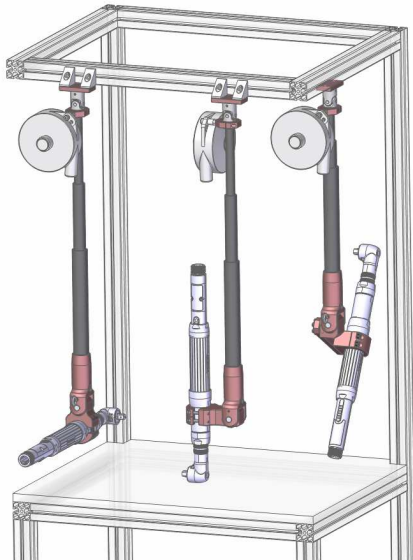

### Mounting on rail

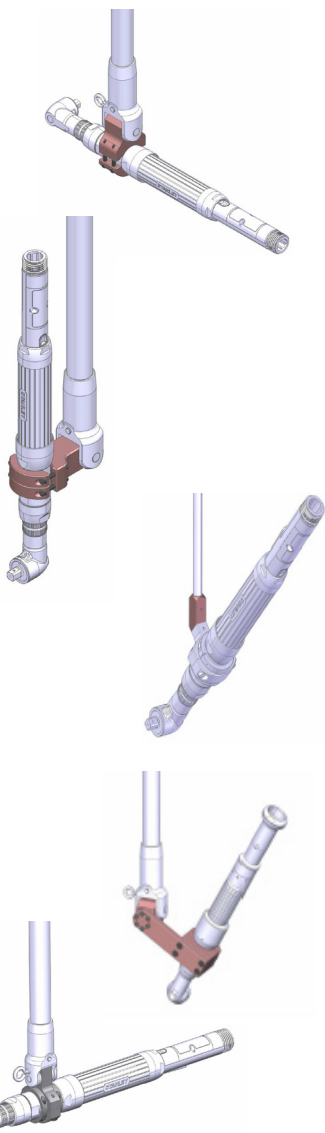
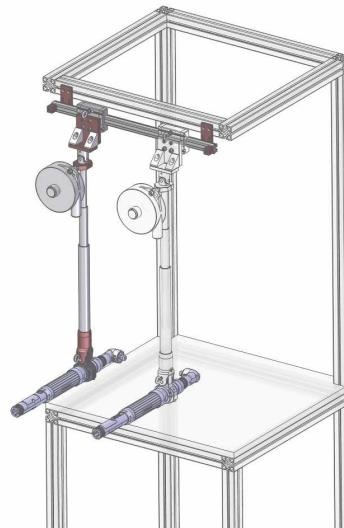

### P2 Clamp

For	Tool Ø	Code
DMF30	28/52	4-1200300
DMFi70	35/52	Standard
DMFi120/200	35/52	Standard
DMFi200	Max 63	Standard
DMF300	Max 73	Standard

### P3 Clamp

For	Tool Ø	Code
DMF30	28/52	4-1200301
DMFi70	35/52	4-1244013
DMFi120/200	35/52	4-1244014
DMFi200	Max 63	4-1244056
DMF300	Max 73	4-1244057

### Tilt interface

For	Tool Ø	Code
Interface / DMF30	-	30° 45° 4-1201140 4-1201141

### Swivel clamp

For	Tool Ø	Code
DMFi70	35/52	4-1201137
DMFi120/200	35/52	4-1201138
DMFi200	Max 63	4-1201139
DMF300	Max 73	On request

### Rotating clamp

For	Tool Ø	Code
DMF30	On request	4-1201134
DMFi70	On request	4-1244034
DMFi120/200	On request	4-1244035
DMFi200	On request	4-1244060
DMF300	On request	4-1201136

# DMF/DMFi

## Mounting on rail

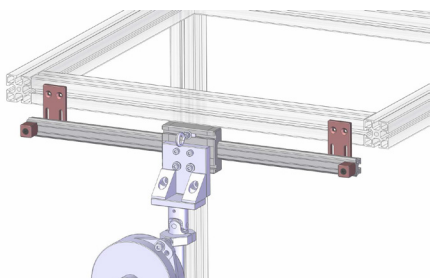

### Rails

Length	Stroke	Number of flanges	Code
600	450	2	4-1200132
800	650	2	4-1200160
1000	850	2	4-1200161
1200	1050	3	4-1200162
1500	1350	3	4-1200163
2000	1850	4	4-1200164

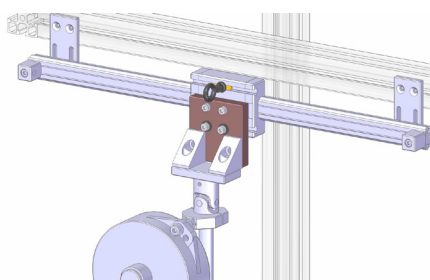

### Rail interface

Allows installation of DMF on rail.

For	Code
DMF12/30	4-1200341
DMFi70/120/200	4-1200708
DMF300	4-1200342

NOTE : delivered without safety hook (Code 4-1200309)

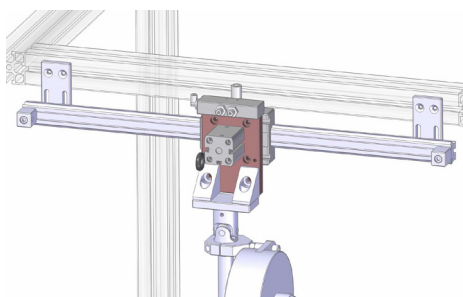

### Pneumatic locker

For	Type	Code
DMF12/30	Pneumatic	4-1200442
DMF12/30	Electric	4-1200869
DMFi70/120	Pneumatic	4-1200706
DMFi70/120	Electric	4-1200707
DMFi200	Electric	4-1201150
DMF300	Electric	4-1201142

The power tool has to be equipped with a motor run signal.

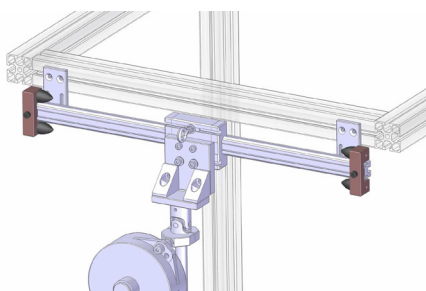

### Absorbing stop

Recommended in case of repeatable side shocks.

Code 4-1201121 Set of 2

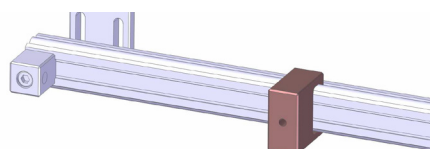

### Adjustable stop

To limit the slide of the arm on the rail.

Code 4-1200167

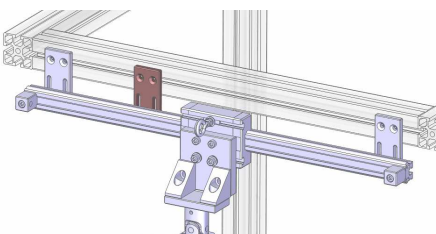

### Additional flange

To reinforce the rail installation for high torque applications.

Code 4-1200873



# Accessories DMF/DMFi

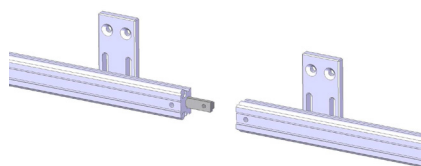

## Rail link

To link two rails together.

Code 4-1200307

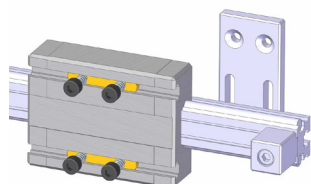

## Single trolley

To mount additional tools on the same rail.

- Single trolley Code 4-1200165

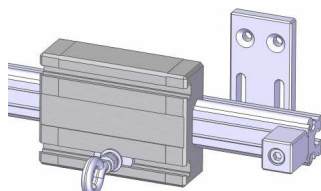

- Trolley for additional balancer Code 4-1200166

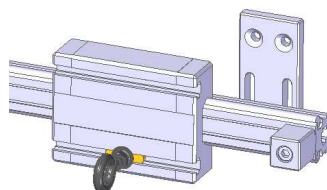

## Additional safety hook

To secure balancer.

Code 4-1200309

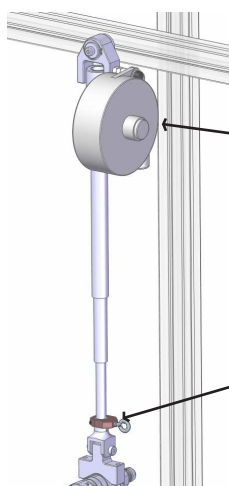

## Balancing kit for DMF 12/30/300

For	Tool (Kg)	Code
DMF12	1 to 2	4-1200303
DMF30	1 to 2,5	4-1200304
DMF30	2 to 4	4-1200305
DMF300	4 to 8	4-1200704
DMF300	6 to 10	4-1200705

Balancer attachment kit for DMF30 Code 4-1201143

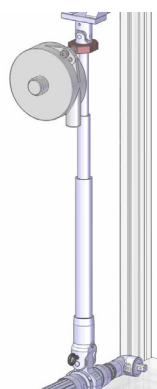

## Balancing kit for DMFi 70/120/200

For	Capacity (Kg)	Code
DMFi 70/120/200	2 - 4	4-1200701
DMFi 70/120/200	4 - 6	4-1200702
DMFi 70/120/200	6 - 8	4-1200703

Delivered with balancer attachment kit.

# Special arms on request

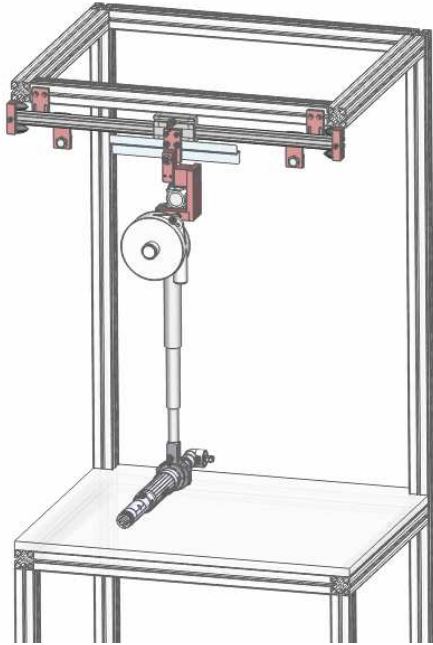

**DMF...PC + horizontal rail with**

Additional presence sensors on the rail allow identification of two working zones (right and left). Contact us for more information.

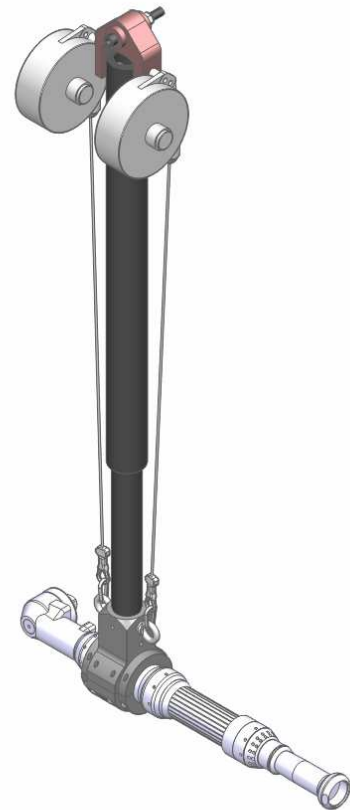

**DMF 300 with rotative clamp and balancing kit**



**DMFi 200 with remote start handle**



**DMFi 600 with air locker + special tool holder for pistol tool**



# Suspended arms

## Slider

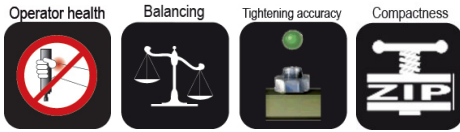

**SLIDER Series : Erase your torque reaction until 300 Nm.**

**• IMPROVE YOUR COMFORT AND PRODUCTIVITY**

Easy to install and smart-sized the SLIDER arms improve the comfort of the operator and the productivity clearing the work area.

**• IMPROVE YOUR ERGONOMY**

Mounted with horizontal stroke the SLIDER becomes the ideal ergonomical solution on conveyor line.

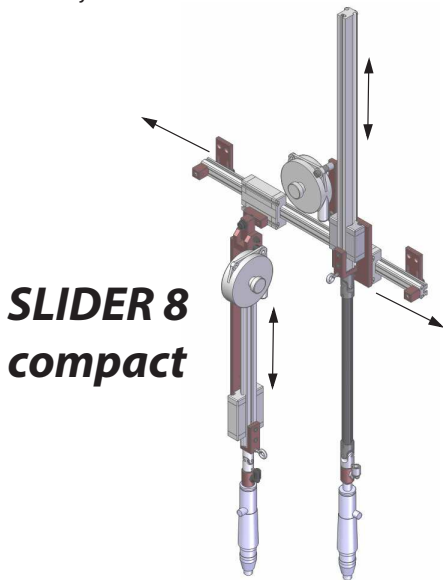

**SLIDER 8  
compact**

**SLIDER 8/20**

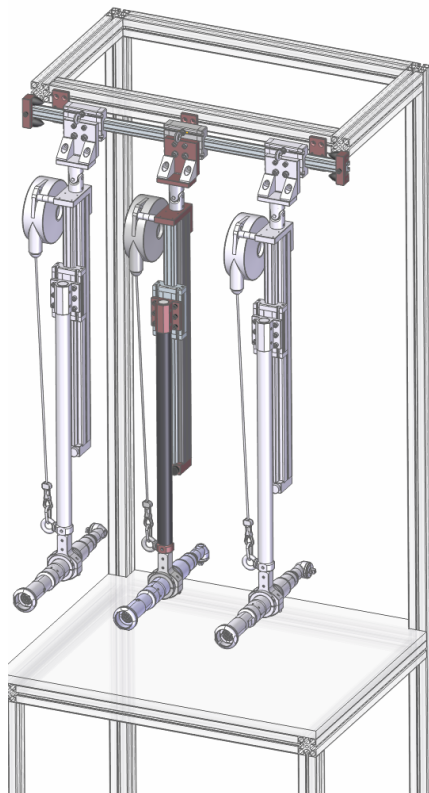

**SLIDER 50/150 COMPACT  
Tightening vertical/horizontal**

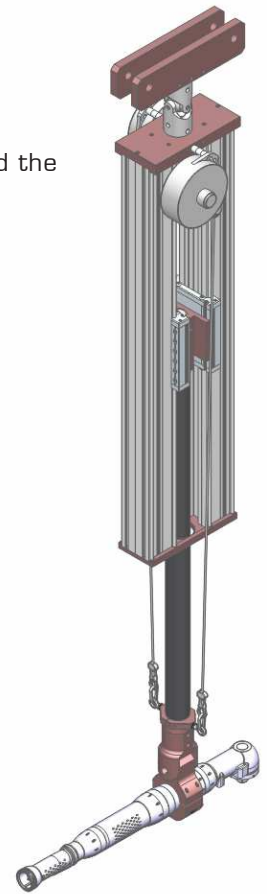

**SLIDER 300  
COMPACT**

Model	Max torque (Nm)	Clamping Ø (mm)	Vertical stroke (mm)	Working radius (mm)	Load (kg)	Code
SLIDER 08	8	1/4" G	450	100	1,2	4-1200077
SLIDER 08 COMPACT	8	1/4" G	250	150	1,2	4-1200179
SLIDER 20	20	1/4" G	450	100	2,2	4-1200457
SLIDER 50 COMPACT 450	50	32 - 52	450		3	4-1283110
SLIDER 50 COMPACT 650	50	32 - 52	650		3	4-1283111
SLIDER 50 COMPACT 850	50	32 - 52	850		3	4-1283112
SLIDER 150 COMPACT 600	150	Max 63	600		5	4-1283113
SLIDER 150 COMPACT 800	150	Max 63	800		5	4-1283114
SLIDER 150 COMPACT 1000	150	Max 63	1000		5	4-1283115
SLIDER 300 COMPACT	300	On request	On request	On request	On request	On request

# Suspended arms

## Options SLIDER

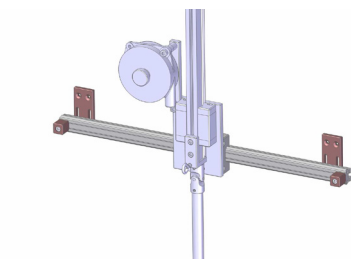

### Rails / SLIDER 8/20/50

Length (mm)	Stroke (mm)	Number of flanges	Code
600	450	2	4-1200132
800	650	2	4-1200160
1000	850	2	4-1200161
1200	1050	3	4-1200162
1500	1350	3	4-1200163
2000	1850	4	4-1200164

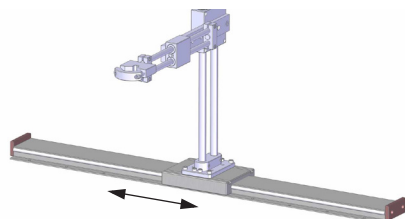

### Rails / SLIDER 150

Model	Length (mm)	Stroke (mm)	Code
Guiding rail	600	420	4-1200294
Guiding rail	1000	820	4-1200295
Guiding rail	1500	1320	4-1200296
Guiding rail	2000	1820	4-1200297

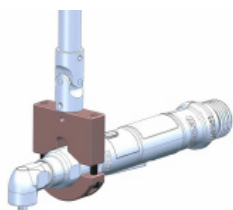

### Clamp option

Clamp Ø28-52 mm for angle nutrunner for SLIDER 20 **Code : 4-1200392.**



### Clamp for straight electric screwdriver

For	Clamping	Tool Ø (mm)	Code
SLIDER 8	On the top of the screwdriver	28 - 52	4-1200133
SLIDER 20	On the top of the screwdriver	28 - 52	4-1200148

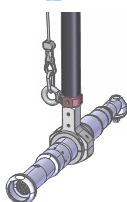

### Rotative clamp

For	Clamping Ø (mm)	Code
SLIDER 50 COMPACT	35 - 52	4-1283116
SLIDER 150 COMPACT	Max 63	4-1283117

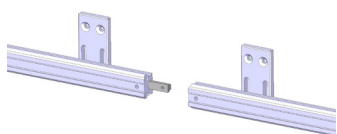

### Rail link

To link two rails together. **Code 4-1200307**

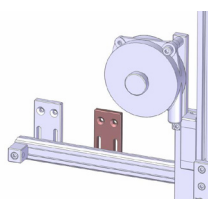

### Additional flange

To reinforce the rail installation for high torque applications.

**Code 4-1200873**

### Rail interface

For	Code
Rail interface for SLIDER50	4-1200708
Rail interface for SLIDER150	4-1200009



# Suspended arms

## SLIDER 8/8 COMPACT/20 Dimensions

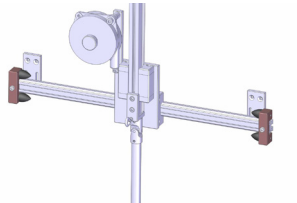

### **Absorbing stop**

Recommended in case of repeatable side shocks.

Code 4-1201121 Set of 2

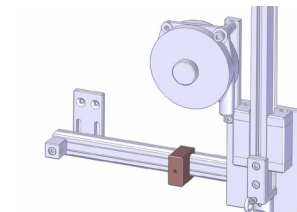

### **Adjustable stop**

To limit the slide of the arm on the rail.

Code 4-1200167

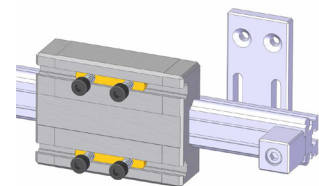

### **Single trolley**

To mount additional tools on the same rail.

- Single trolley Code 4-1200165

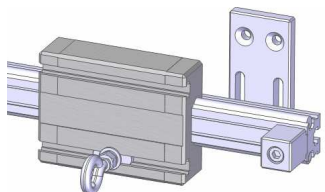

- Trolley for additional balancer Code 4-1200166

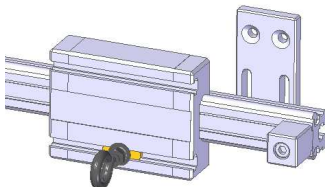

### **Additional safety tool hook**

To secure balancer. Code 4-1200309



# Suspended arms

## SLIDER 8/20 Dimensions

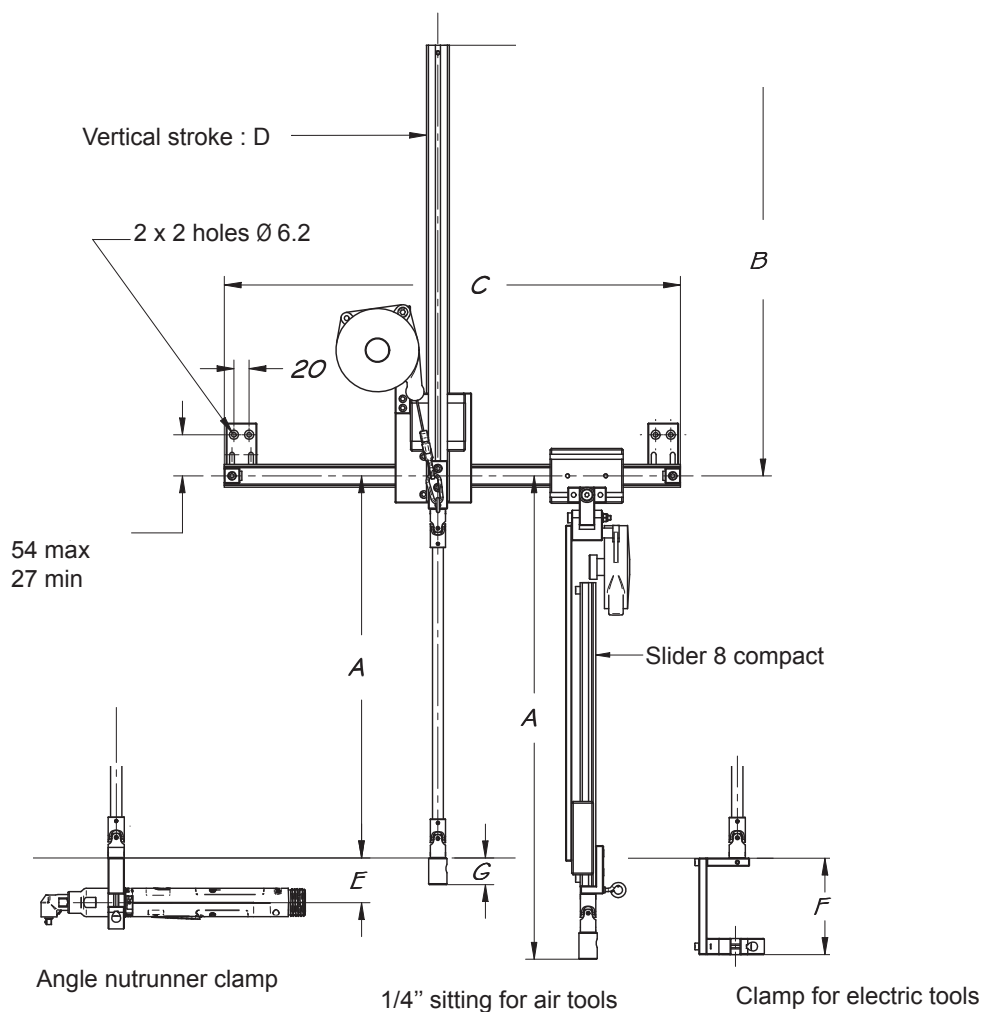

## Dimensions

Model	A	B	Vertical stroke D	E	F	G
SLIDER 8	500	565	450	/	120	35
SLIDER 8 COMPACT	550 to 600	/	270	/	120	35
SLIDER 20	500	599	450	56	120	35

## Rails

Stroke	Length : C
450	600
650	800
850	1000
1050	1200
1350	1500
1850	2000



# Suspended arms

## SLIDER BA / SLIDER BA...R Series

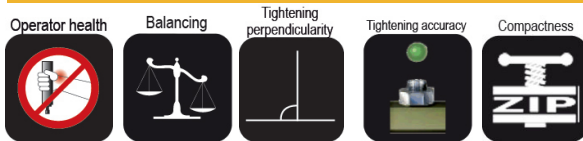

Mounted on the top, the working area remains free. The SLIDER Series can be installed on rail. Then a pneumatic locker is necessary to counter react.

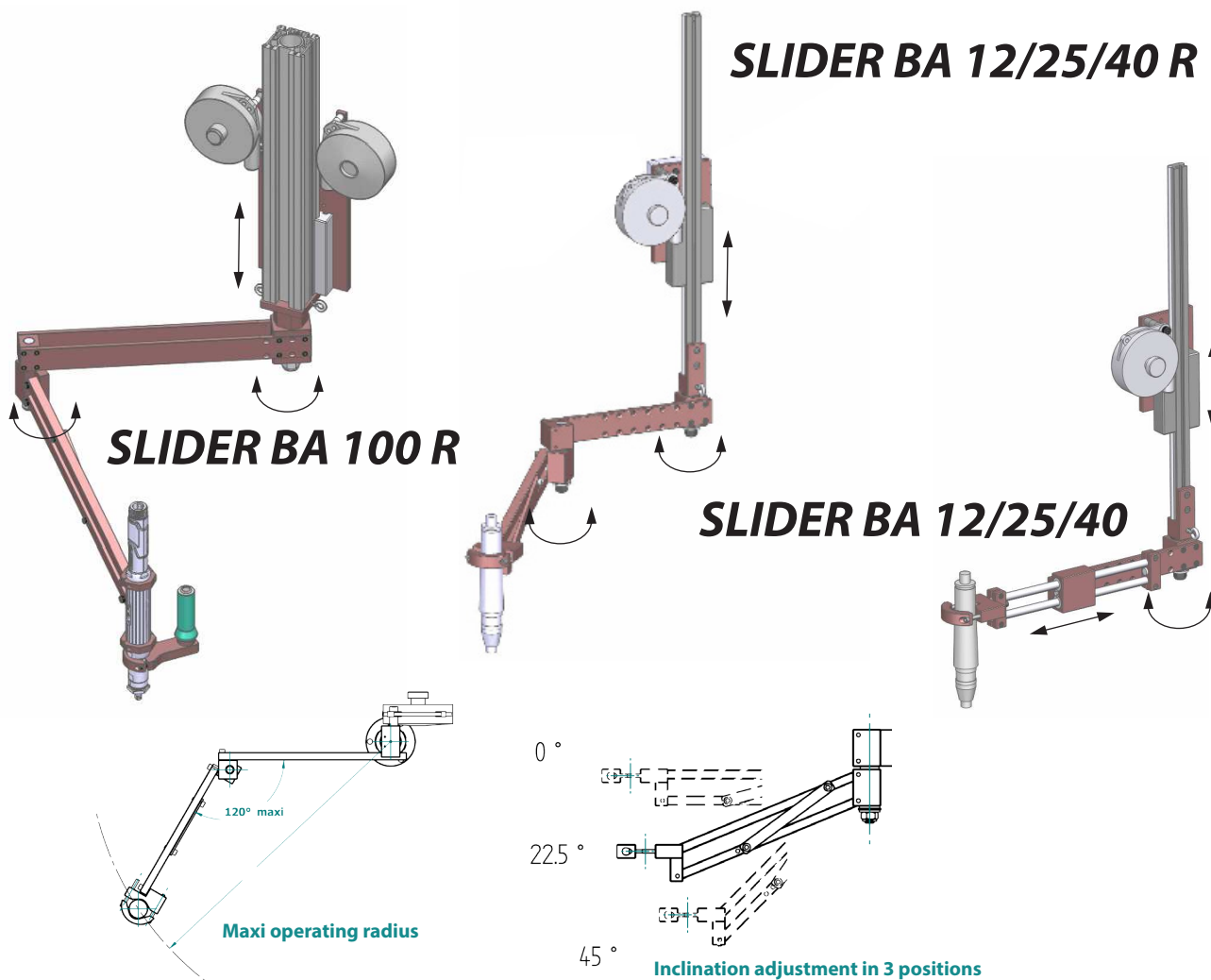

Model	Max torque (Nm)	Tool Ø (mm)	Vertical stroke (mm)	Stroke (mm)	Operating range (mm)	Load (kg)	Code
SLIDER BA 12	12	25/50	420	225		1,2	4-1201007
SLIDER BA 25	25	28/52	420	250		2,2	4-1200726
SLIDER BA 40	40	28/52	420	295		3	4-1201119
SLIDER BA 100	100	28/52	420	330		5	4-1201120
SLIDER BA 12 R	12	25/50	420		450	1,2	4-1201008
SLIDER BA 25 R	25	28/52	420		460	2,2	4-1200872
SLIDER BA 25 R/600	25	28/52	420		600	2,2	4-1201114
SLIDER BA 40 R	40	28/52	420		650	3	4-1201115
SLIDER BA 40 R/800	40	28/52	420		800	3	4-1201116
SLIDER BA 100 R	100	28/52	420		730	5	4-1201117
SLIDER BA 100 R/900	100	28/52	420		900	5	4-1201118

# Suspended arms

## SLIDER BA / BA...R Dimensions

### SLIDER BA...R

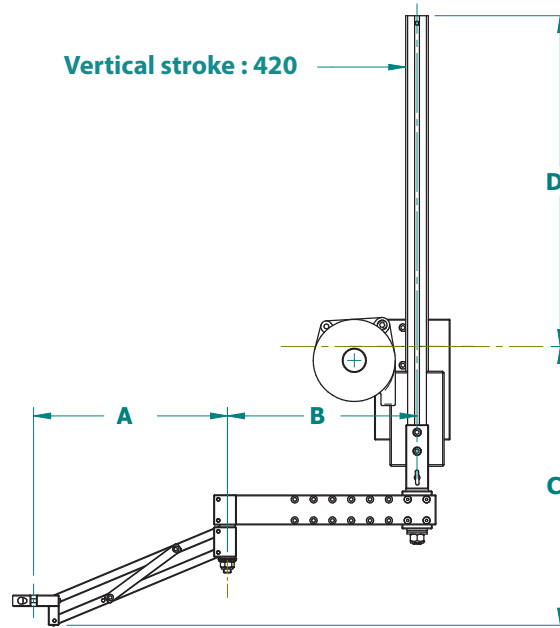

22.5°

Model	A	B mini	B maxi	Operating range at 120°	C	D
SLIDER BA 12 R	261	102	252	474	370	440
SLIDER BA 25 R	278	95	245	485	394	425
SLIDER BA 25 R/600	336	305	330	607	417	425
SLIDER BA 40 R	387,5	150	350	667	482	419
SLIDER BA 40 R/800	470	415	415	800	496	419
SLIDER BA 100 R	433	205	405	730	597	358
SLIDER BA 100 R/900	528	470	520	900	634	358

### SLIDER BA...

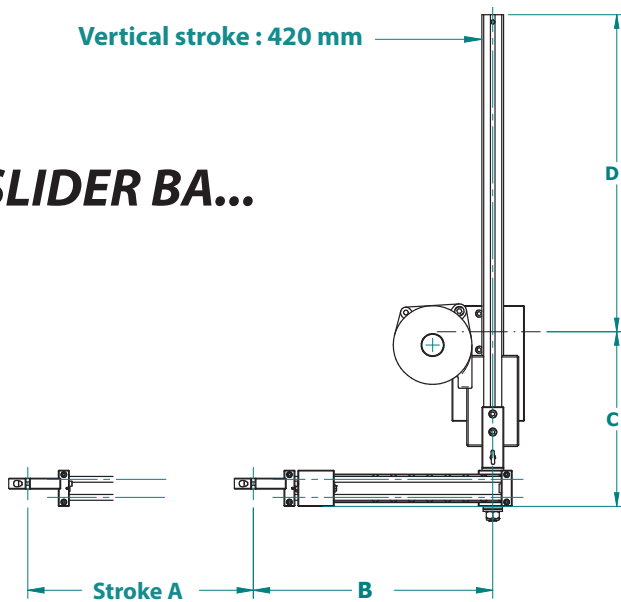

#### Mounting dimensions SLIDER BA... BA...R

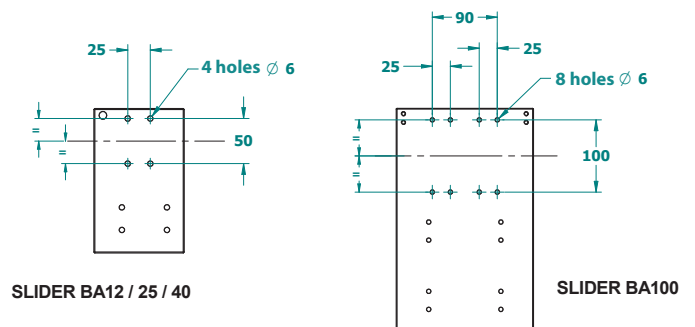

Model	Stroke A	B mini	B maxi	C	D
SLIDER BA 12	225	186	336	246	436
SLIDER BA 25	250	221	396	250	436
SLIDER BA 40	295	260	460	314	419
SLIDER BA 100	330	315	515	395	358

# Position control system

Improve your manufacturing quality with zero fault process. DOGA Posi Control system is the ideal Sequencing, Error proofing and positioning unit. Compatible with your air, electric and DC tools, your assembly process remains under control regardless operator's qualification.

- Page 37 • Posi-control arms
- Page 38 at 39 • Controller DPC-Touch
- Page 40 at 41 • Linear arms BA...PC series
- Page 42 at 43 • Articulated arms BA...RPC series
- Page 44 at 47 • Telescoping carbon arms
- Page 48 at 49 • Suspended arms



*DPC-Touch Controller*

# POSI-CONTROL

Position control

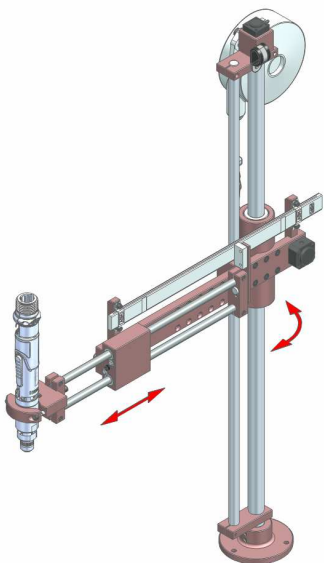

Linear arms BA...PC series

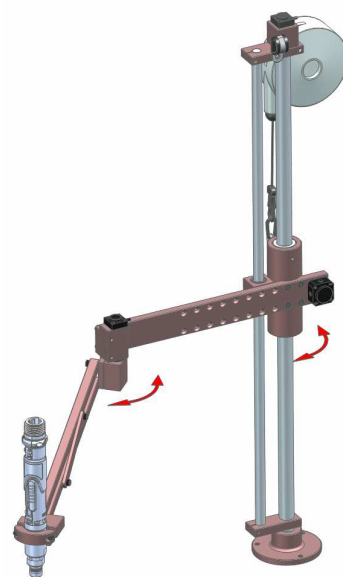

Articulated arms BA...RPC series



- Zero fault process
- Error proofing
- Sequencing
- Suitable with air and electric tools
- Automation device management

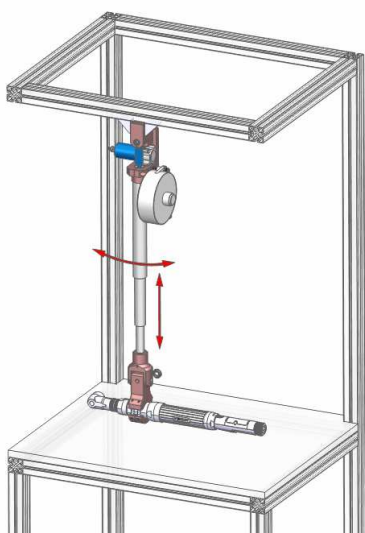

Telescoping arms DMF...PC series

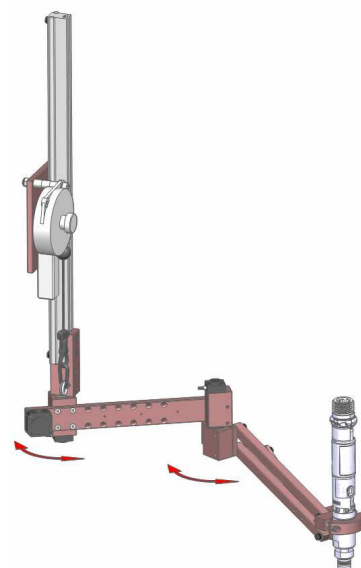

Suspended arms Slider BA...RPC series

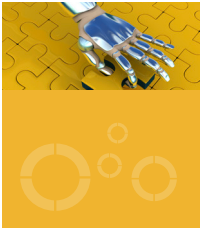

# POSI-CONTROL System

- Open job structure allows set up of customized logical sequences of fastenings, messages and I/O's.

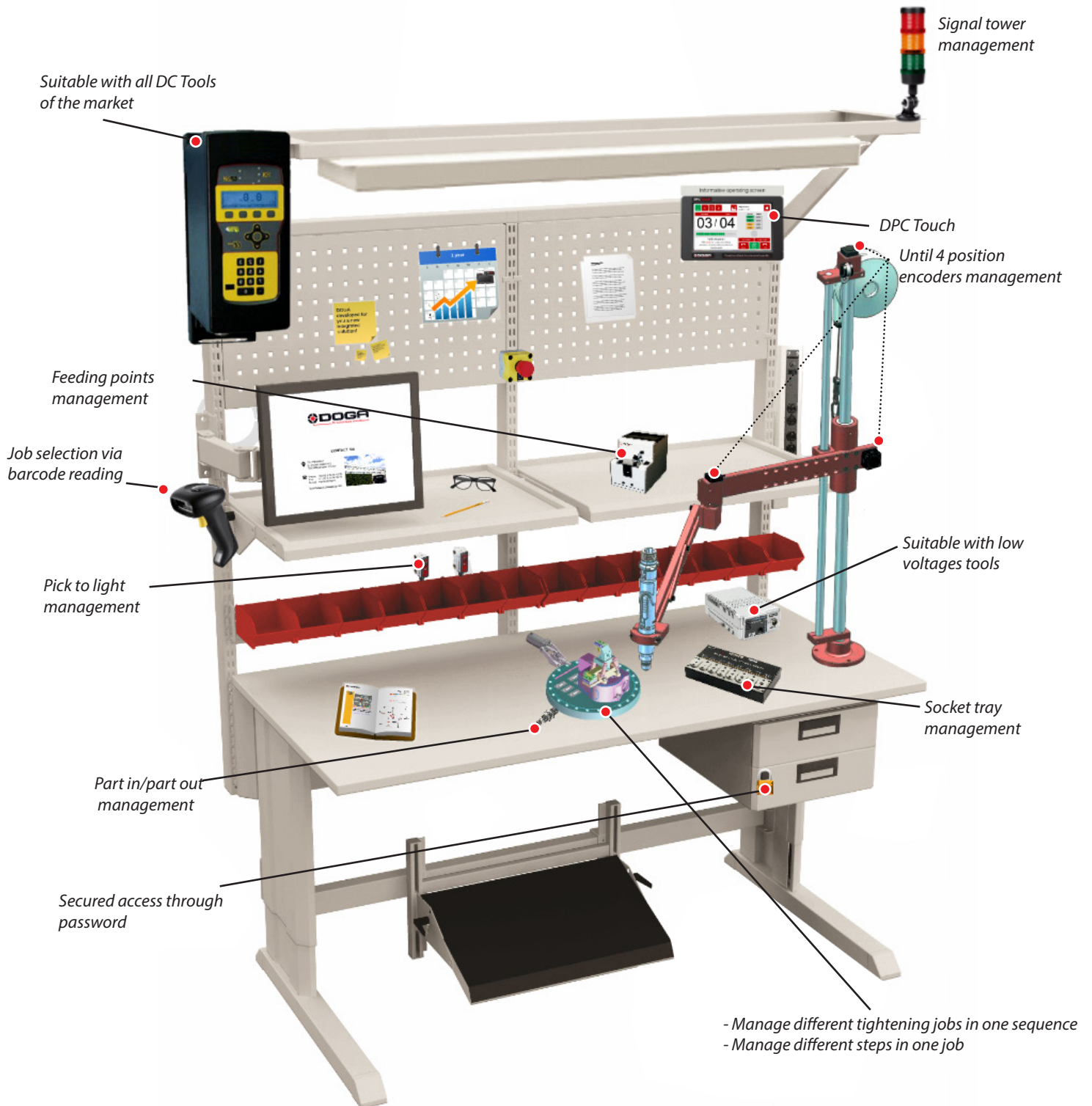

- More than a sequencing and Poka-Yoke controller the DPC Touch may easily manage the automation devices of your workstation on assembly line.

# POSI-CONTROL DPC-Touch

Powerful - user friendly - versatile



• TECHNICAL FEATURES :

Dimensions : 202 x 127 x 38 mm

Weight : 550 gr

I/O's : 12 inputs, 12 outputs, 24 Volts

LCD screen : 7" touch screen (800 x 480 m/m)

Encoders : until 4 encoders, [0 - 5 V]

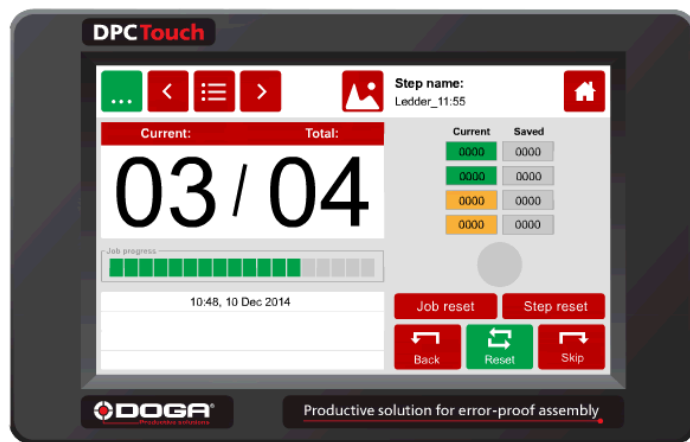

Power supply

2 ports for low voltage DOGA screwdrivers

12 inputs/12 outputs (assignable)

Encoders port

RS232 port (firmware upgrade and bar code reading/Job selection)

• Fast and powerful :

- In house operating system
- Until 999 programable jobs !
- Until 255 steps per jobs !
- Until 99 positions per step !
- Until 4 position encoders

• Versatile :

- Suitable with all DC Tools - low voltage and air tools
- Poka-Yoke or/and sequencing controller
- Assignable I/O's
- Suitable with screwfeeders pick up
- Opened job structure enables customized logical sequences
- Management of your automation devices

• User friendly :

- Embedded soft
- Touch screen
- Self teaching sequencing
- Smart tolerance detection
- Process and sequencing visualization - operator instructions guidance

Model	Code
DPC Touch	6-1274100
DPC Touch / GX, GY, DO, GA cable	6-1041620
DPC Touch / DOGA HD, SD cable	6-1252002
DPC Touch / Stanley TAU/THETA cable	4-1241036
DPC Touch / Stanley KAPPA, ALPHA cable	4-1241050
DB9 3m/free wires (4 outputs/3 inputs) cable	4-1200542
DB25 3m/free wires (9 outputs/12 inputs) cable	4-1200770
DB44 3m/free wires (12 outputs/12 inputs) cable	6-1041621
Air kit for pneumatic tool / DPC Touch	4-1200771
Firmware upgrade kit	6-1200004



# Linear arms

## BA...PC Series

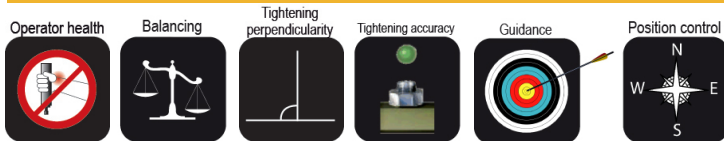

- Torque up to 100 Nm
- Equipped with absolute angle encoders (12 bits)
- Higher torque is available on request

### BA 12/25/40/100 PC

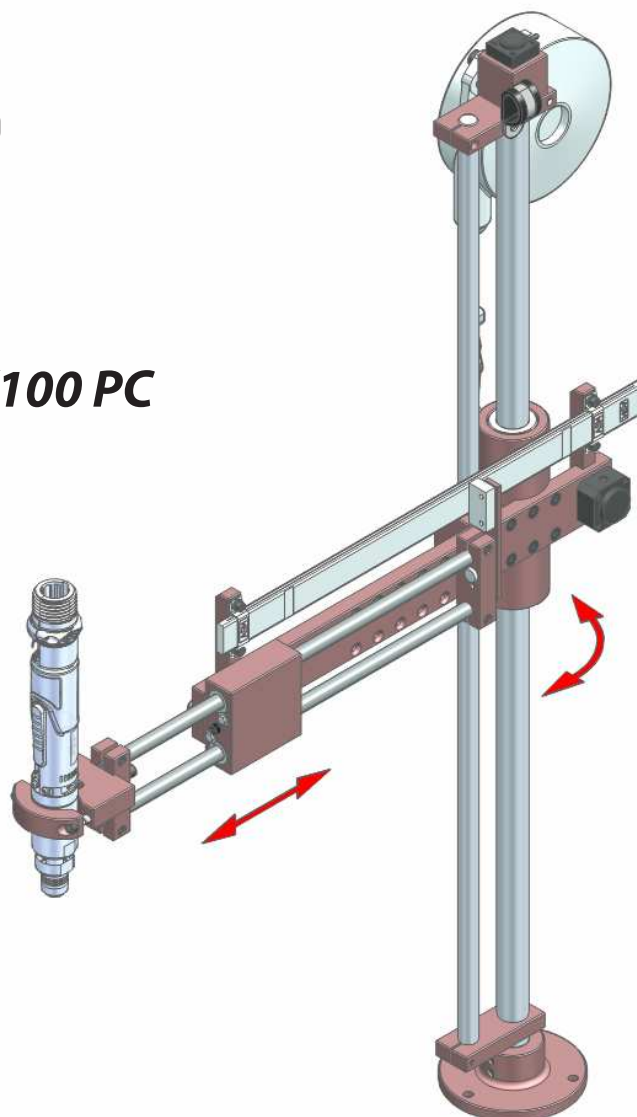

Model	Max torque (Nm)	Tool Ø (mm)	Stroke (mm)	Max load (Kg)	Code
BA 12 PC	12	25 - 50	195	1,2	4-1201009
BA 25 PC	25	28 - 52	195	2,2	4-1201086
BA 40 PC	40	28 - 52	295	3	4-1201087
BA 40 PC/400	40	28 - 52	395	3	4-1201088
BA 100 PC	100	28 - 52	295	4	4-1201089
BA 100 PC/400	100	28 - 52	395	4	4-1201091



# Linear arms

## BA...PC Dimensions

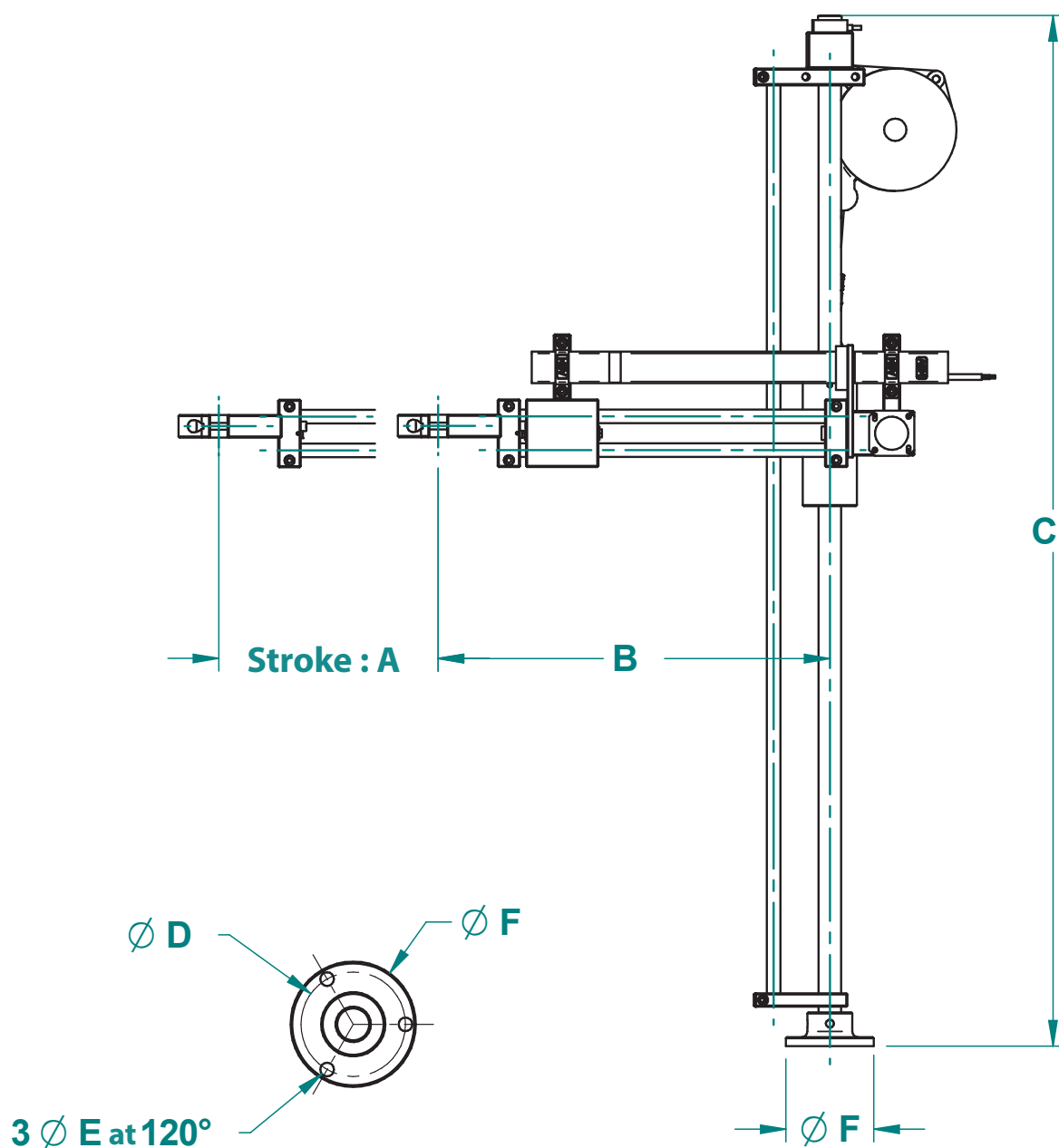

Model	Stroke A	B mini	B maxi	C	D	E	F
BA 12 PC	195	236	336	816	65	8,5	78
BA 25 PC	195	251	351	916	65	8,5	78
BA 40 PC/300	295	320	470	1016	100	8,5	118
BA 40 PC/400	395	420	570	1016	100	8,5	118
BA 100 PC/300	295	335	485	1016	126	10,5	148
BA 100 PC/400	395	435	585	1016	126	10,5	148



# Articulated arms

## BA...RPC Series

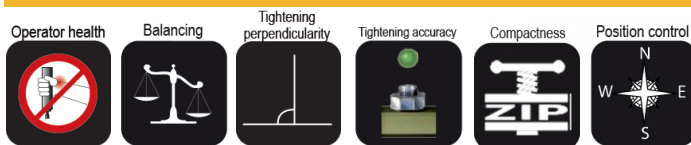

- Torque up to 100 Nm
- Operating range up to 1100 mm
- Equipped with two absolute angle encoders 12 bits (0,1°)
- Higher torque is available on request

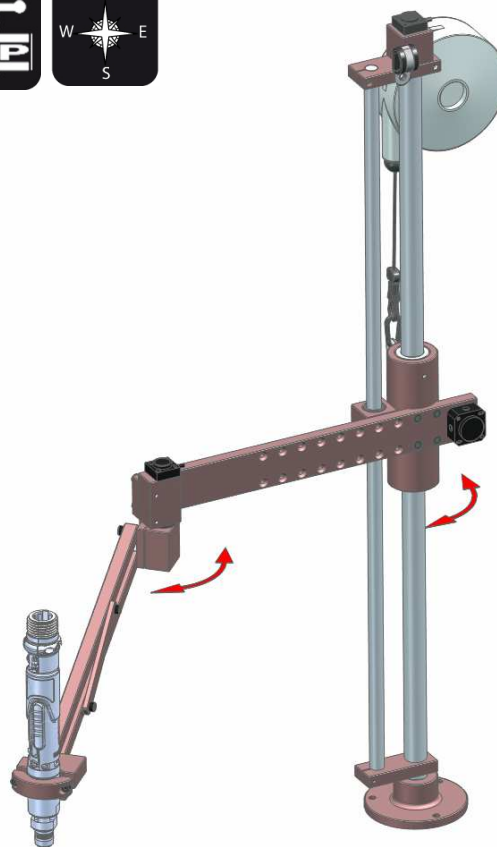

### BA 12/25/40/100 RPC

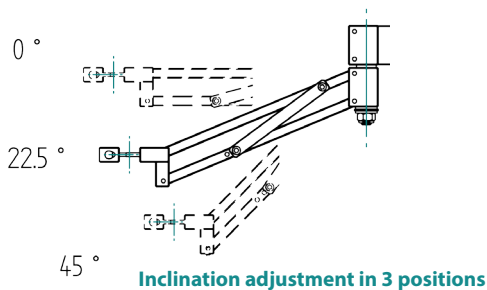
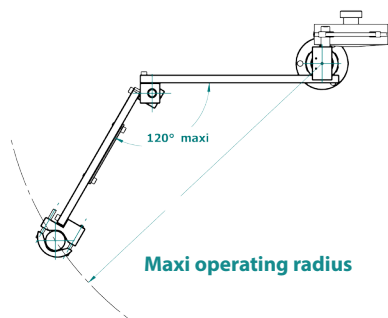

Model	Max torque (Nm)	Tool Ø (mm)	Operating range (mm)	Max load (Kg)	Code
BA 12 RPC	12	25 - 50	450	1,2	4-1201010
BA 25 RPC	25	28 - 52	460	2,2	4-1200472
BA 25 RPC/600	25	28 - 52	600	2,2	4-1200475
BA 40 RPC	40	28 - 52	650	3	4-1200473
BA 40 RPC/800	40	28 - 52	800	3	4-1200476
BA 100 RPC	100	28 - 52	730	4	4-1200474
BA 100 RPC/900	100	28 - 52	900	4	4-1200477
BA 100 RPC/1100	100	28 - 52	1100	4	4-1200478

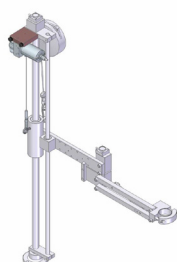

### Option

Z encoder / BA RPC. **Code : 4-1283125.**  
Encoder cable Z. **Code 4-1200725.**

# Articulated arms

## BA...RPC Series Dimensions

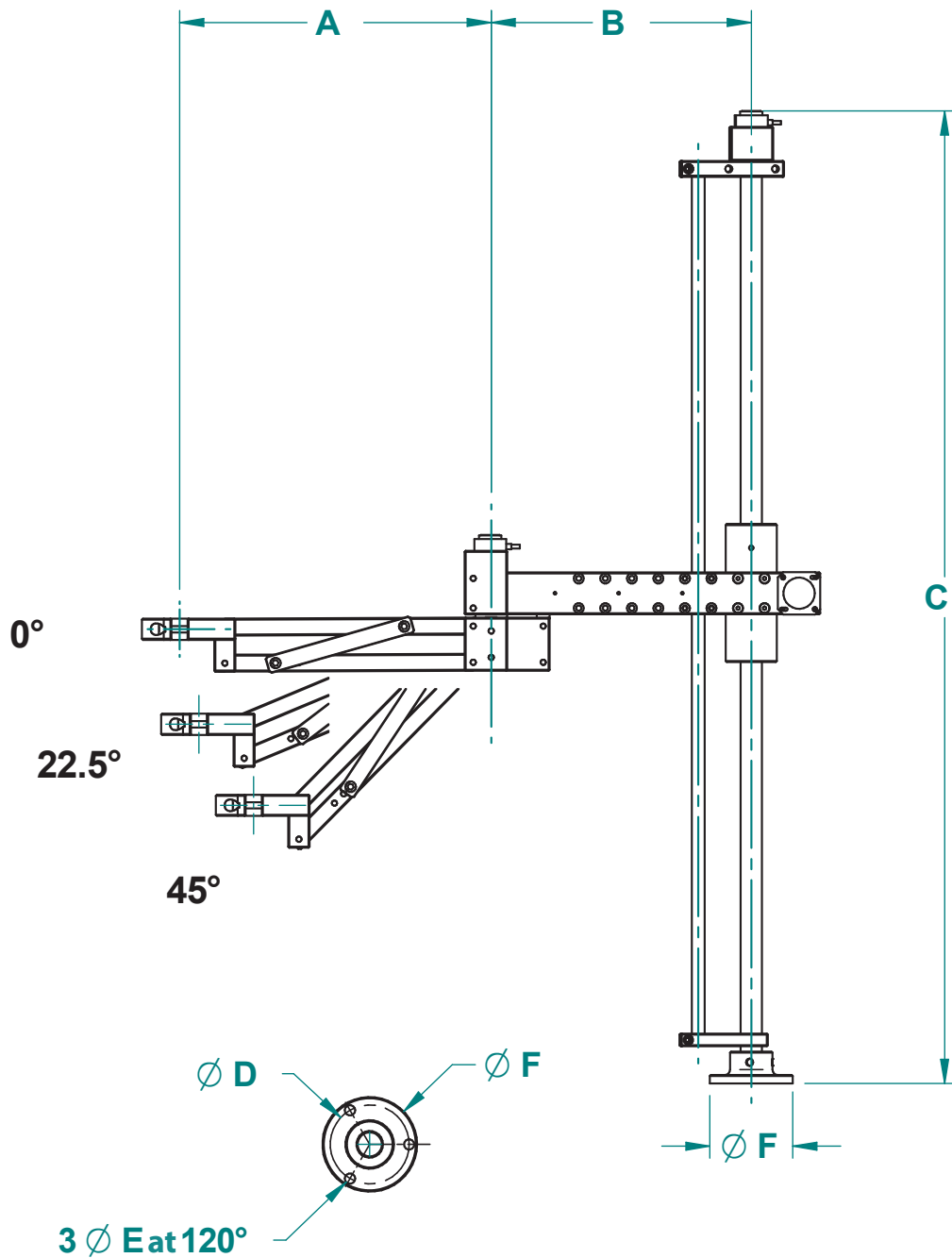

Model	A 0°	A 22,5°	A 45°	B min	B max	C	Operating range at 22,5°
BA 12 RPC	279	261	209	145	245	816	450
BA 25 RPC	296	278	227	145	245	916	460
BA 25 RPC/600	358	336	271	330	330	916	600
BA 40 RPC	414	387,5	310,5	200	350	1016	650
BA 40 RPC/800	503	470	374	415	415	1016	800
BA 100 RPC	462	433	351	255	405	1016	730
BA 100 RPC/900	564	528	425	520	520	1016	900
BA 100 RPC/1100	694	648	517	635	635	1016	1100

D, E, F similar to BA...R

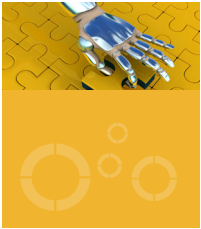

# Carbon telescoping arms

## DMF...PC Series

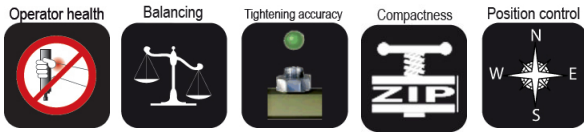

- Torque up to 140 Nm
  - Equipped with absolute angle encoders 12 bits (0,1°)
- ↔ Monitored movement

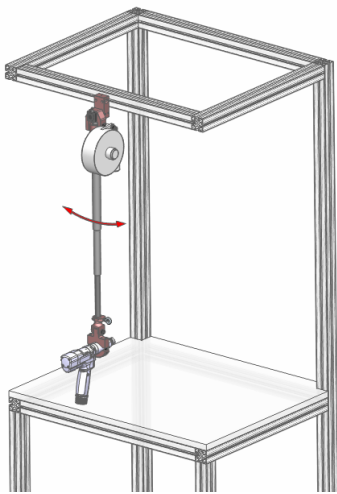

**DMF APC**

*Equipped with one angle encoder*

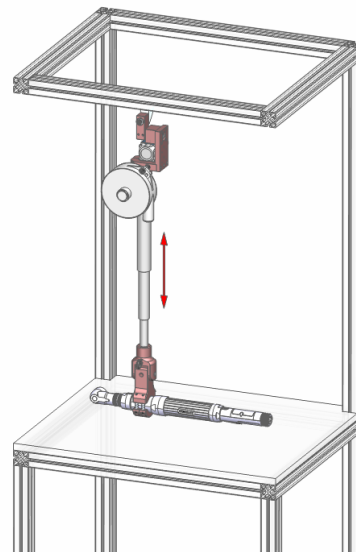

**DMF LPC**

*Equipped with one length encoder*

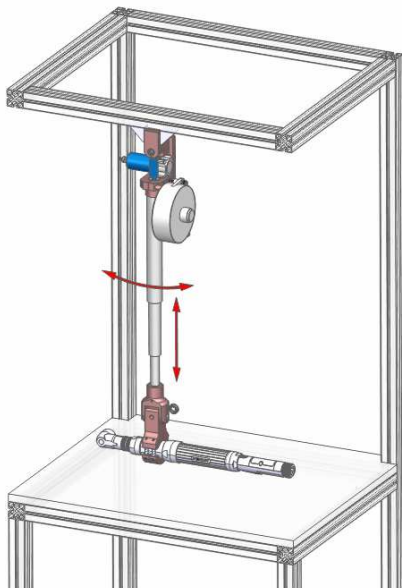

**DMF LAPC**

*Equipped with one length encoder and one angle encoder*

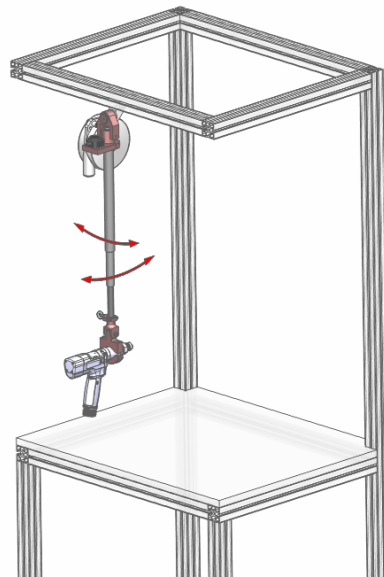

**DMF AAPC**

*Equipped with two angle encoders (inclinometer)*

# Carbon telescoping arms

## DMF...PC Series

### DMF APC



### DMF LPC/LAPC

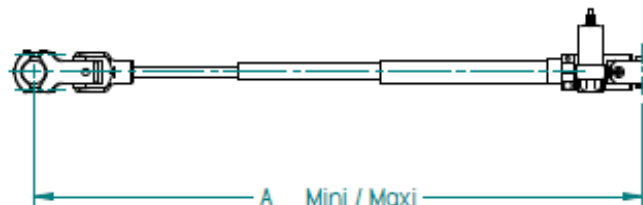

Model	Torque	Clamp	Tool Ø	Min	Max	Code without clamp	Code with clamp
DMF 30 APC/960	30	P1	28-52	560	960	4-1200574	4-1200564
DMF 30 APC/1500	30	P1		706	1500	4-1200575	4-1200565
DMF 30 APC/2000	30	P1		873	2000	4-1200576	4-1200566
DMF 80 APC/1500	80	P2/P3	35-52	764	1500	4-1200577	4-1200567
DMF 80 APC/2000	80	P2/P3		930	2000	4-1200578	4-1200568
DMF 140 APC/1500	140	P2/P3		978	1500	4-1200579	4-1200569
DMF 140 APC/2000	140	P2/P3		1228	2000	4-1200580	4-1200572
DMF 30 LPC/960	30	P1	28-52	560	960	4-1200588	4-1200581
DMF 30 LPC/1500	30	P1		727	1500	4-1200589	4-1200582
DMF 30 LPC/2000	30	P1		894	2000	4-1200590	4-1200583
DMF 80 LPC/1500	80	P2/P3	35-52	780	1500	4-1200591	4-1200584
DMF 80 LPC/2000	80	P2/P3		947	2000	4-1200592	4-1200585
DMF 140 LPC/1500	140	P2/P3		991	1500	4-1200593	4-1200586
DMF 140 LPC/2000	140	P2/P3		1241	2000	4-1200594	4-1200587
DMF 30 LAPC/960	30	P1	28-52	560	960	4-1200662	4-1200595
DMF 30 LAPC/1500	30	P1		727	1500	4-1200663	4-1200596
DMF 30 LAPC/2000	30	P1		894	2000	4-1200664	4-1200597
DMF 80 LAPC/1500	80	P2/P3	35-52	780	1500	4-1200665	4-1200598
DMF 80 LAPC/2000	80	P2/P3		947	2000	4-1200666	4-1200599
DMF 140 LAPC/1500	140	P2/P3		991	1500	4-1200667	4-1200660
DMF 140 LAPC/2000	140	P2/P3		1241	2000	4-1200668	4-1200661

## AAPC Option

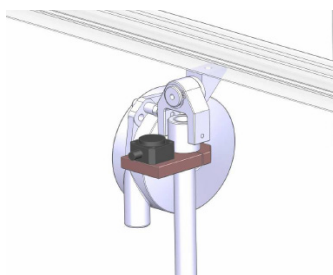

*Inclinometer may be installed on standard DMF arms (DMF30, DMFi 70/120/200) to monitor angular position.*

For	Code
DMF 30	4-1200809
DMFi 70/120/200	4-1200810



# Carbon telescoping arms

## Clamps for DMF...PC

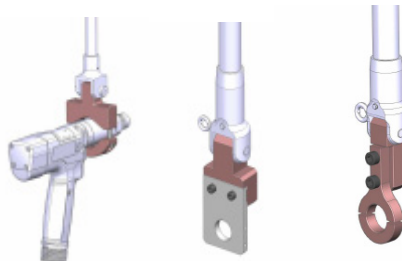

### P1 clamp

For	P1	Tool Ø
DMF 30	Standard	28/52
DMF 80/140	Mounting plate interface	On request

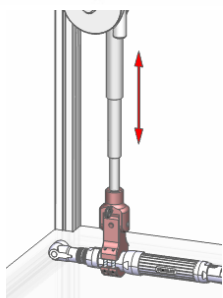

### P2 clamp

For	Tool Ø	Code
DMF 30	28/52	4-1200300
DMF 80/140	35/52	Standard



### P3 clamp

For	Tool Ø	Code
DMF 30	28/52	4-1200301
DMF 80/140	35/52	Standard

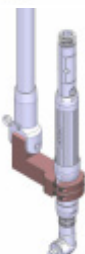

### P4 clamp

For	Tool Ø	Code
DMF 30	28/52	4-1200302
DMF 80/140	35/52	4-1200343



### Tilt interface

For	Code
DMF 30 30°	4-1201140
DMF 30 45°	4-1201141

### Swivel clamp

For	Tool Ø	Code
DMF 80/140	On request	On request

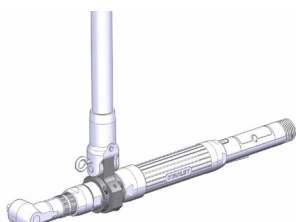

### P2 Rotating clamp

For	Tool Ø	Code
DMF 30	On request	4-1201134
DMF 80/140	On request	4-1201135

# Carbon telescoping arms

## DMF...PC Accessories

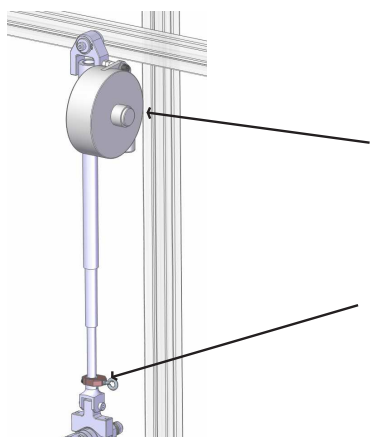

### Balancing kit for DMF...PC

Max load tool (kg)	For	Code
1/2,5	DMF 30	4-1200304
2/4	DMF 30/80	4-1200305
4/6	DMF 80/140	4-1200306

Balancer attachment kit for DMF30 **Code 4-1201143.**

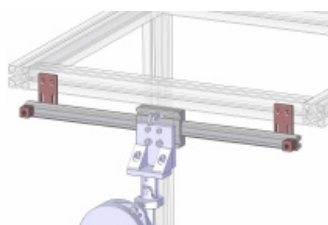

### Rails

Length	Stroke	Number of flanges	Code
600	450	2	4-1200132
800	650	2	4-1200160
1000	850	2	4-1200161
1200	1050	3	4-1200162
1500	1350	3	4-1200163
2000	1850	4	4-1200164

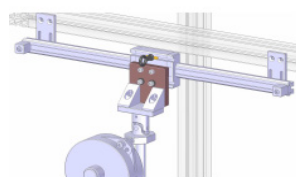

### Rail interface

Allows installation of DMF on rail.

For	Code
DMF 30/80/140	4-1200341
DMF 300	4-1200342

**NOTE** : delivered without safety hook (**Code 4-1200309**)

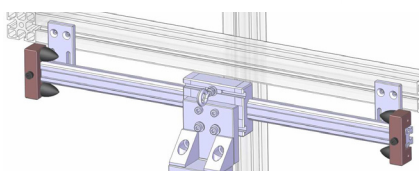

### Absorbing stop

Recommended in case of repeatable side shocks.

**Code 4-1201121** Set of 2

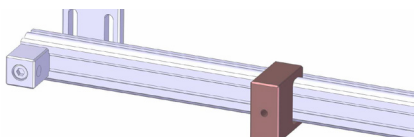

### Adjustable stop

To limit the slide of the arm on the rail.

**Code 4-1200167**

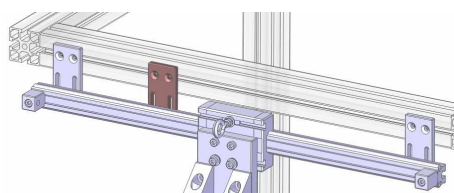

### Additional flange

To reinforce the rail installation for high torque applications.

**Code 4-1200873**

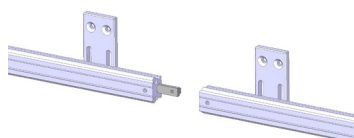

### Rail link

To link two rails together.

**Code 4-1200307**



# Suspended arms

## SLIDER BA...PC/RPC

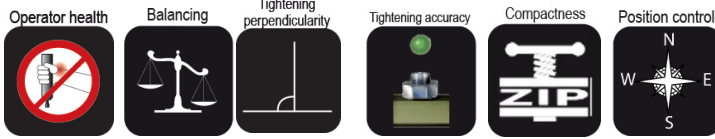

- Torque up to 100 Nm
- Operating range up to 900 mm
- Equipped with 2 absolute encoders 12 bits (0,1°)
- Higher torque available on request

←→ Monitored movement

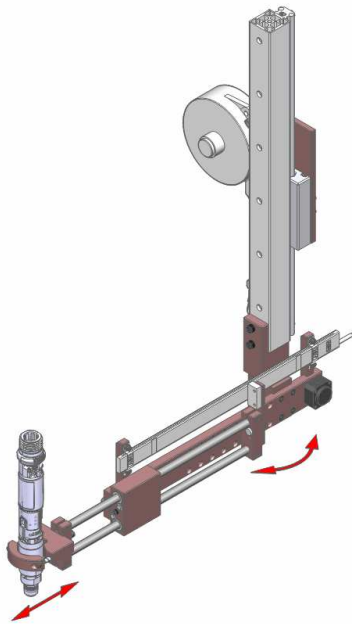

**SLIDER BA 12/25/40 PC**

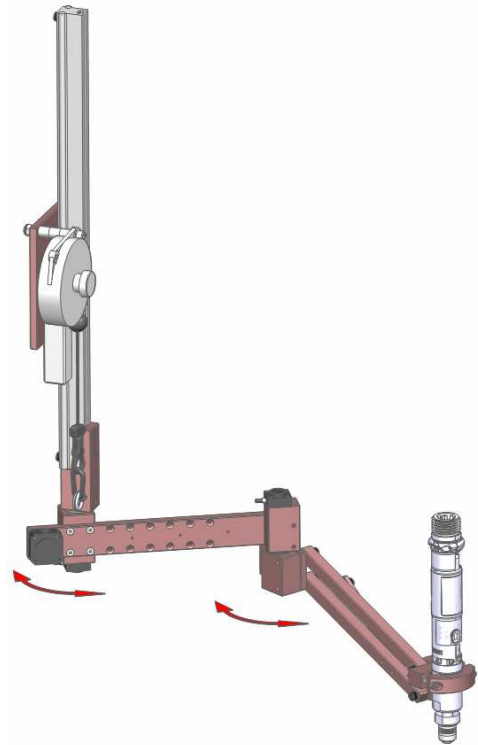

**SLIDER BA 12/25/40/100 RPC**

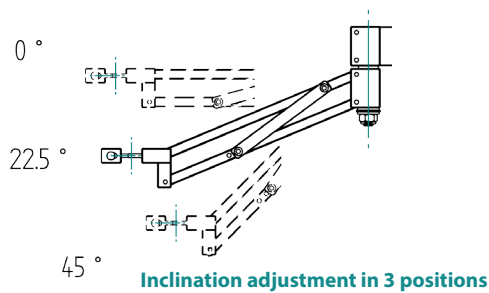
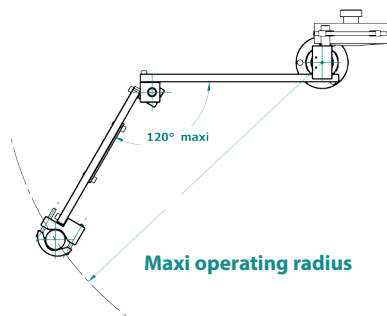

Model	Max torque (Nm)	Tool Ø (mm)	Operating range (mm)	Stroke (mm)	Operating range (mm)	Max load (Kg)	Code
SLIDER BA 12 PC	12	25/50	420	195		1,2	4-1283120
SLIDER BA 25 PC	25	28/52	420	195		2,2	4-1283121
SLIDER BA 40 PC	40	28/52	420	295		3	4-1283122
SLIDER BA 12 RPC	12	25/50	420		450	1,2	4-1201078
SLIDER BA 25 RPC	25	28/52	420		460	2,2	4-1201079
SLIDER BA 25 RPC/600	25	28/52	420		600	2,2	4-1201080
SLIDER BA 40 RPC	40	28/52	420		650	3	4-1201081
SLIDER BA 40 RPC/800	40	28/52	420		800	3	4-1201082
SLIDER BA 100 RPC	100	28/52	420		730	4	4-1201083
SLIDER BA 100 RPC/900	100	28/52	420		900	4	4-1201084



# Suspended arms

## SLIDER BA...RPC Dimensions

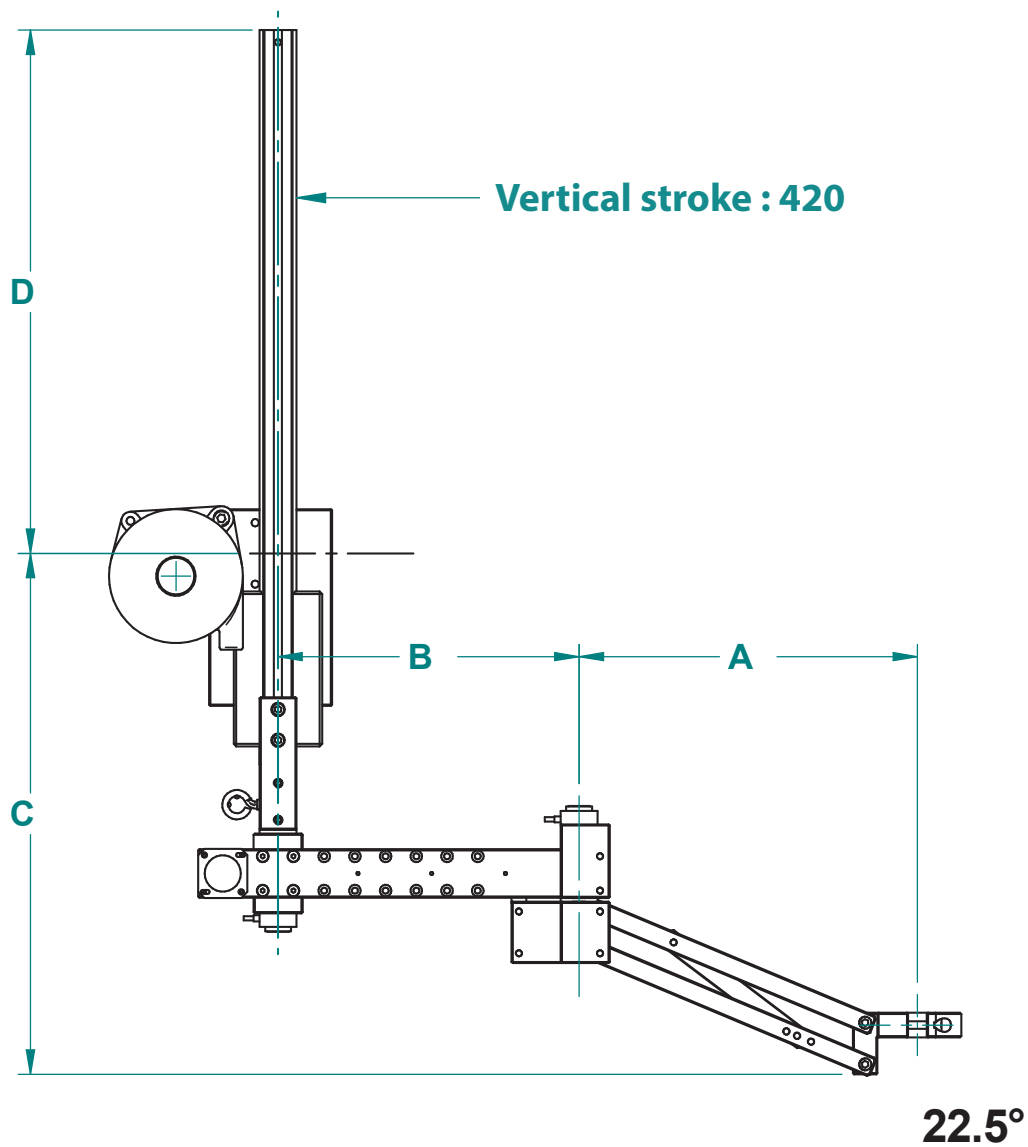

	A	B min	B max	Operating range at 22,5°	C	D
SLIDER BA 12 RPC	261	102	252	474	380	440
SLIDER BA 25 RPC	278	95	245	485	424	425
SLIDER BA 25 RPC/600	336	305	330	607	447	425
SLIDER BA 40 RPC	387,5	150	350	667	482	419
SLIDER BA 40 RPC/800	470	415	415	801	496	419
SLIDER BA 100 RPC	433	205	405	758	597	358
SLIDER BA 100 RPC/900	528	470	520	908	634	358



# Special arms

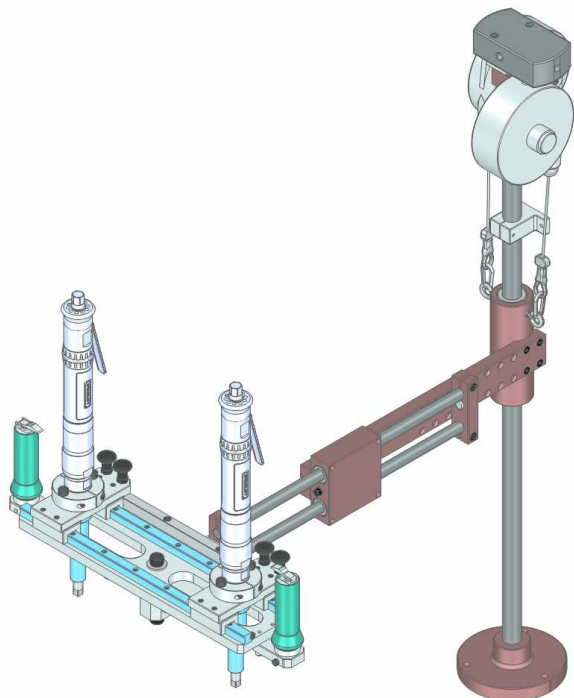

**BA for double spindle with variable pitch**

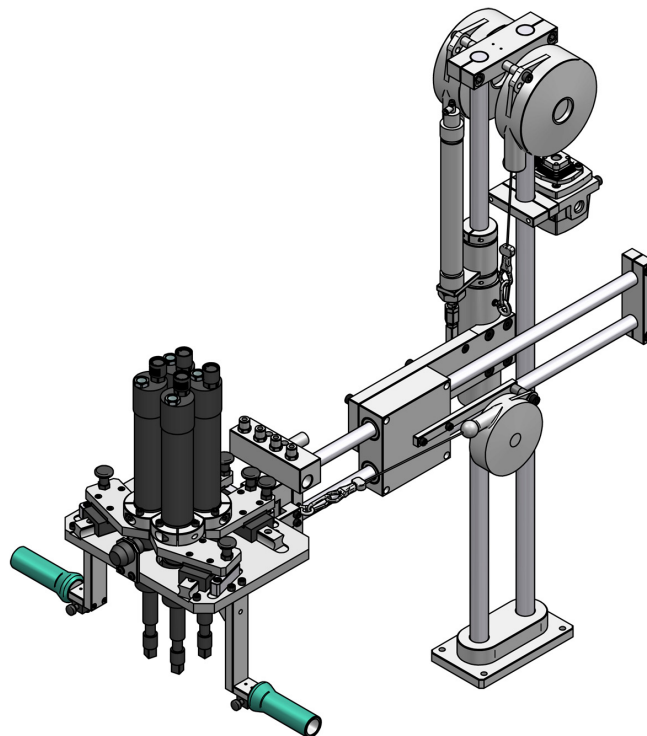

**BA 200 with 4 spindles + easy push kit**



**SLIDER 50 COMPACT :**

- With rail
- With air locker
- With rotative clamp

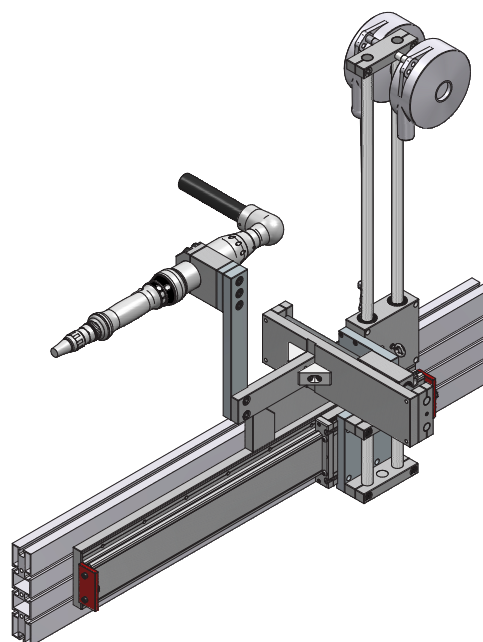

**Cartesian arm, 3 axes**

# Special arms

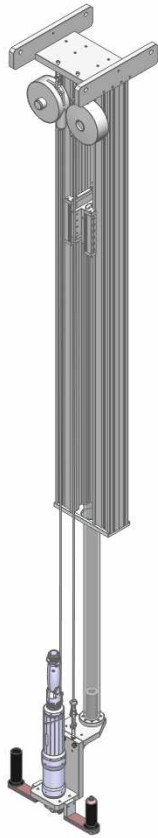

**SLIDER 300 COMPACT for straight nutrunner**

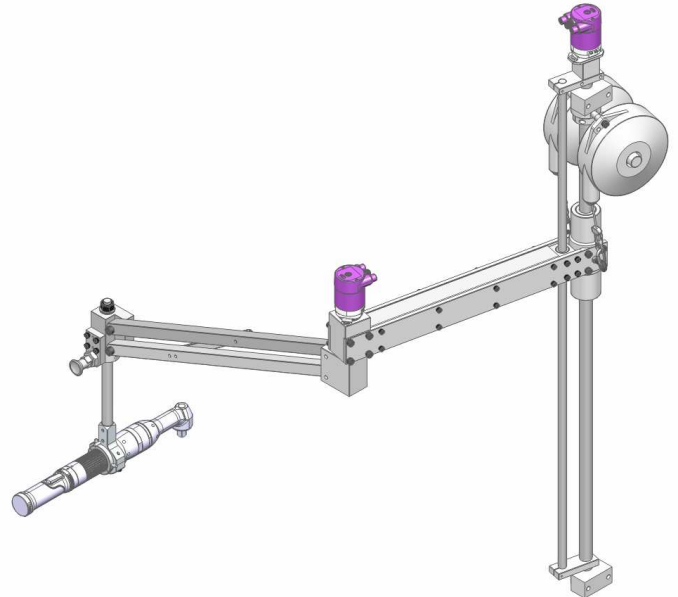

**BA 180 R with :**  
- Profinet coders  
- Rotative and swivelling clamp

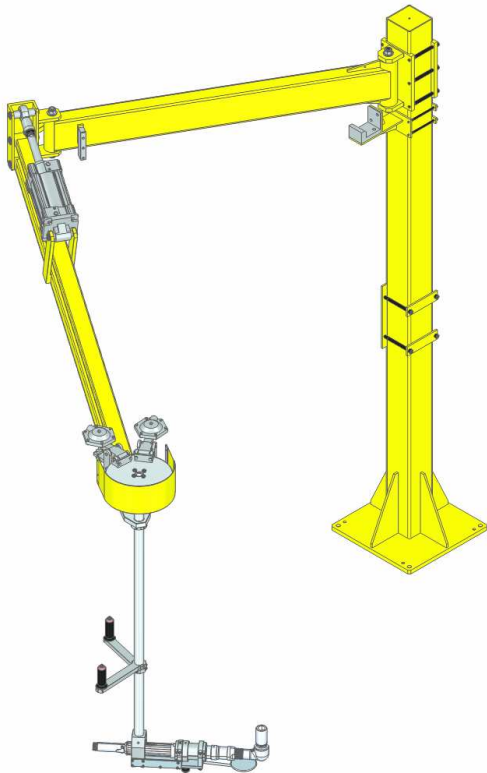

**BA 500R/3000 with :**  
- Disk break  
- Rotative clamp

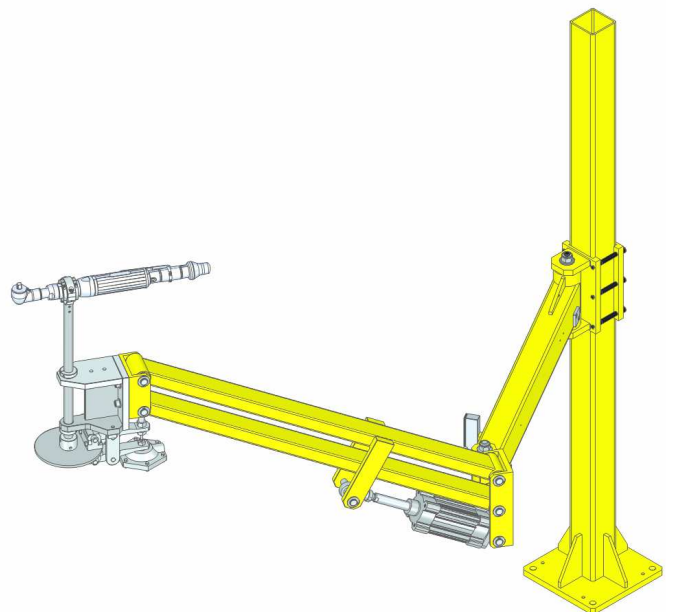

**BA 200 R for under body tightening :**  
- With disk break  
- Rotative clamp



8, avenue Gutenberg - CS 50510  
78317 Maurepas Cedex - France  
Tél. : +33 (0)1 30 66 41 20 • Fax : +33 (0)1 30 66 41 79  
[export@doga.fr](mailto:export@doga.fr)



Nous travaillons constamment à l'amélioration de nos produits. De ce fait, les dimensions et indications portées dans cette brochure peuvent parfois ne pas correspondre aux dernières exécutions. De convention expresse, nos ventes sont faites sous bénéfice de réserve de propriété (les dispositions de la loi du 12/5/80 trouvent donc toute leur application).