

Ingersoll Rand ARO

Lubrication Equipment Catalog



Contents

Lubrication Equipment Introduction	2
Piston Pumps	7
Piston Pump Accessories	10
Grease Pumps	12
Grease Pump Accessories	14
Diaphragm Pumps	17
Diaphragm Pump Accessories	22
Hose Reels	24
Control Handles	29
Control Handle Accessories	31
Hand-operated Pumps	32
Hand-held Grease Guns	33
Fittings and Accessories	34
General Installation Accessories	36
Filters, Regulators, and Lubricators	42
Self-evacuating Waste Oil caddies	46
Waste Oil and Fresh Oil Caddy Systems	47
Oil Drains and Accessories	49
Bulk Fluid Management	50
Bulk Oil Tanks	51
Warranty Policy	55
Contact Information	56

Lubrication Equipment Warranty

Ingersoll Rand / ARO lubrication equipment is built with the finest materials to deliver reliable products with extended durability. Our warranty is your assurance of a quality product. See your Ingersoll Rand distributor for details.



Lubrication Equipment

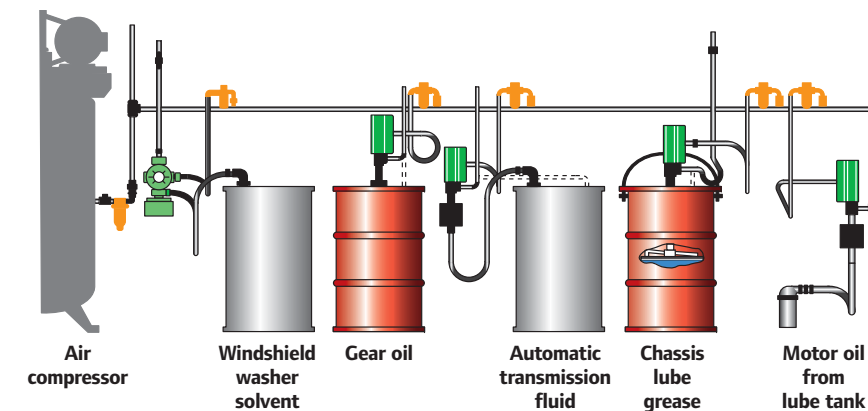

Ingersoll Rand / ARO lubrication equipment reflects the same high standards of performance as our tools and air compressors, with a full range of products that will keep all types of fluids moving efficiently. They are backed by more than 70 years of experience in pump and air system technology, and include models specifically designed for popular applications.

- Piston pumps for grease ... or for motor oil, gear oil, and transmission fluid
- Unique design improves flow, reduces pulsation, and extends service life
- 50 percent fewer parts than comparable pumps
- Fast, easy, in-line service, with no special tools required
- Stall-free, ice-free air motor with tough, durable housing
- Diaphragm pumps for drum use with oil and other light fluids ... or for direct use with anti-freeze, water, windshield cleaning fluid, fuel, solvents, oils, transmission fluid, and waste oil
- Patented unshalttable air valve applies constant pressure to ensure resets
- Bolted construction provides better joint integrity and fast, easy servicing
- No lubrication or complex controls required
- Digital / metered fluid control handles that are precise and easy to use
- High-pressure grease control handles
- Hand-held grease guns
- Convenient hose reels for a clean, safe workplace
- Professional grade oil drains
- Full range of general lubrication fittings and accessories

All Ingersoll Rand / ARO lubrication equipment is built to a global quality standard to deliver unmatched dependability and productivity.

Call your distributor for complete details and recommendations for your facility.

Typical Quick-lube Installation

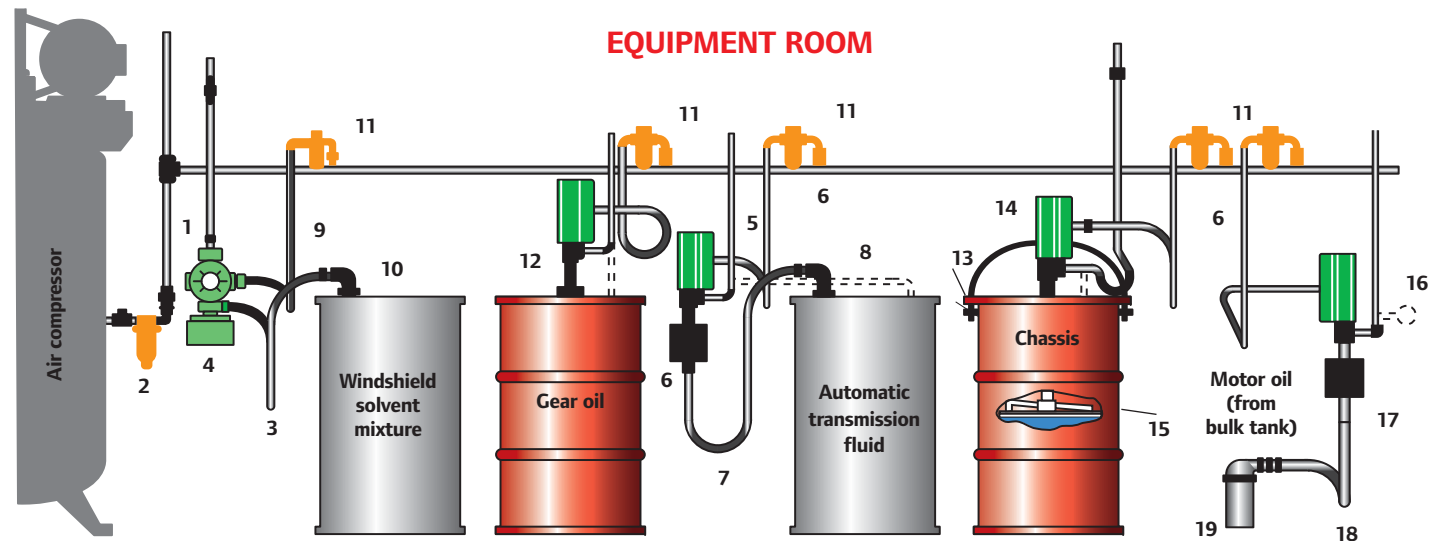

1. Pump: PD05P-ARS-PTT-B
2. 1/2" air line filter: F25241-110
3. 1/2" material hose: 623501-5
4. Wall-mount bracket: 76763
5. Pump: LM2305A-11-B
6. Wall-mount bracket: 61113
7. 1-1/2" ID material hose (by others)
8. Siphon tube assembly: 66779 with 1-1/2" (F) x 1" reducing bushing
9. 1/4" ID air hose: 622201-3
10. Siphon tube assembly: 61409
11. Air line filter / regulator: P29221-610 (gauge included)
12. Pump: LM2305A-41-B (55-gal service)
13. Single-post lift: 640067 (400-lb service)
14. Pump: LP3005-1 (400 lb. service) LP3002-1 (120 lb. service)
15. Follower plate assembly: 640015-1 (400# service) 640165 (120# service) (included with LP3002-1)
16. Pump: LM2305A-11-B
17. Wall-mount bracket: 61113
18. 1-1/2" ID material hose: (by others)
19. 1" pipe swivel union: 75368 with 1-1/2" (F) x 1" (M) reducing bushing

High-pressure relief valve Kit: 61118.

Windshield solvent, automatic transmission fluid anti-freeze

An excellent delivery pump for all types of fluids, the Ingersoll Rand / ARO 1/2" diaphragm pump is the best-selling diaphragm pump in the country – and it's covered by a 5-year warranty.



Model PD05P-ARS-PTT-B
1:1 ratio
13 gpm
(free flow)

Motor/gear oil, automatic transmission fluid

This reliable, hard-working pump comes complete with air coupler and connector, plus a 2" bung adapter.



Model LM2305A-41-B
5:1 ratio, 3" air motor
9 gpm
(free flow)

Chassis

Designed for high-pressure delivery of grease, the pump will handle your toughest chassis lube needs. Comes with air / material hose plus drum cover.



Model LP3005-1
50:1 ratio, 3" air motor
7.5 ppm
(free flow)

Waste oil

The Ingersoll Rand / ARO 1" diaphragm pump's simple design will provide years of trouble-free waste oil handling. All of our diaphragm pumps are covered by a 5-year warranty for an extra measure of user security.



Model 666100-3C9-C
1:1 ratio
35 gpm
(free flow)

Typical Quick-lube Installation (continued)

PIT AREA

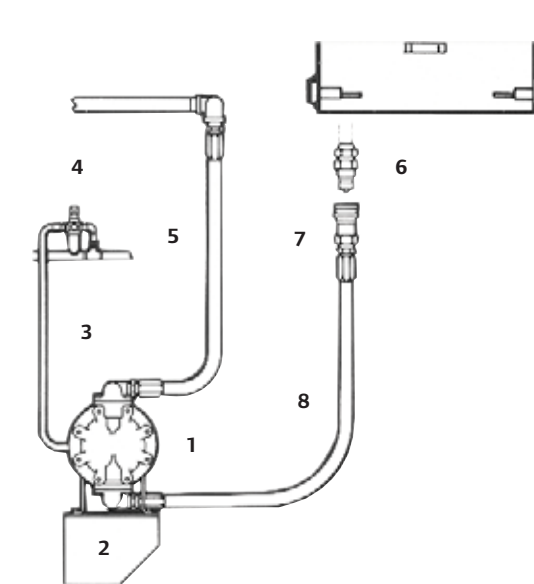

Waste oil system

1. 1" diaphragm pump: 666100-3C9-C
2. Wall-mount bracket: 66100
3. 1/4" air hose: 622201-5
4. Air line filter / regulator, gauge: P29122-600
5. 1" ID material outlet hose: 628067-3
6. Fluid connector: 92022
7. Fluid coupler: 92021
8. 1" ID material inlet hose: 628066-6

Chassis service

1. High-pressure control handle: 636111 Swivel: 636077
2. 1/4" ID material hose: 624201-10
3. 1/2" high-pressure shut-off valve: 636042 (order separately)

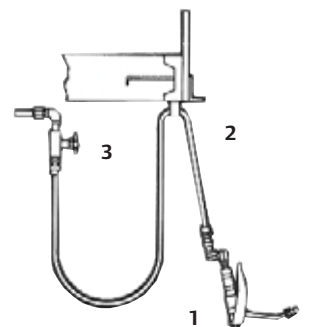

Gear oil service

1. Control handle: 635391-1
2. 1/2" material hose: 623501-10 In-line meter: 635190-1
3. 1/2" medium-pressure shut-off valve: 66592 (order separately)

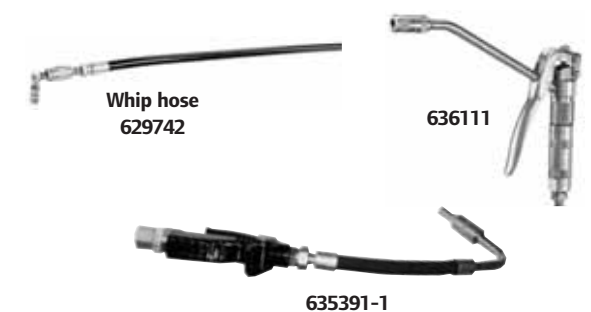
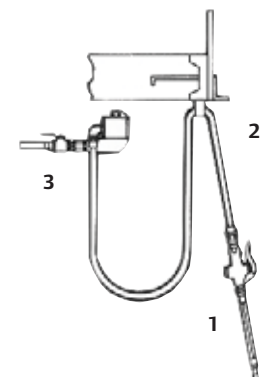

Lubrication Equipment Quick Reference

The illustration on these pages represents a typical layout for service fluids.

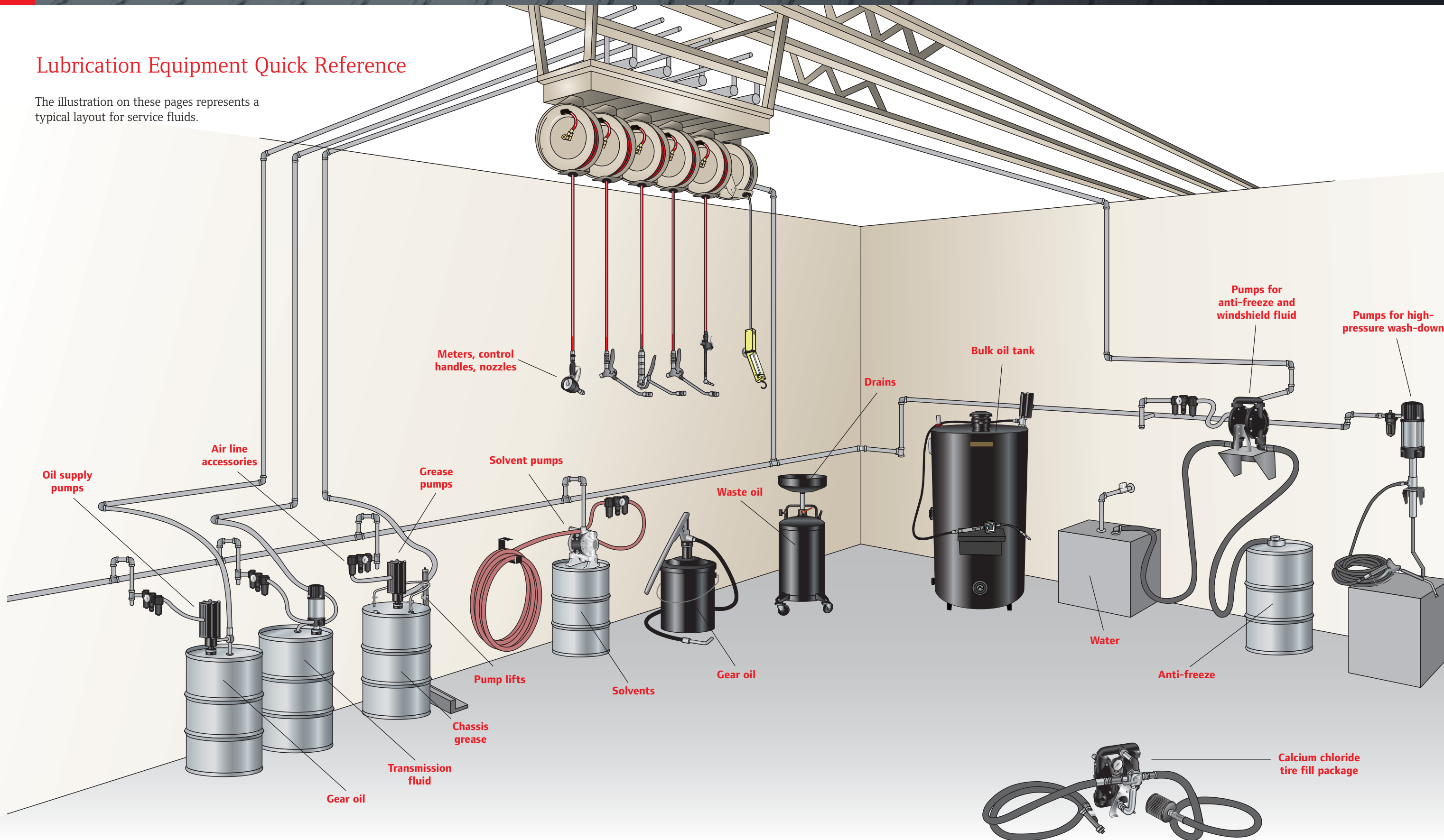

Piston Pumps

LM Series Piston Pumps

Built tough to fit the way you work

LM Series piston pumps deliver unmatched industrial-strength performance for pumping fluids with sizes to fit small (16 gal / 35 lb) or large (275 gal / 400 lb) containers. Working flow rates range from two to six gallons per minute. Pumps are offered from 3:1 to 50:1 ratios, in order to meet the requirements of any application.

Features and benefits

- Pump's patented design improves flow, reduces pulsation, and extends service life
- Offers simple self-service maintenance due to advanced design with 50% fewer parts
- Reduces service time, due to in-line service design with no special tools required
- Features stall-free, ice-free air motor with tough, durable housing

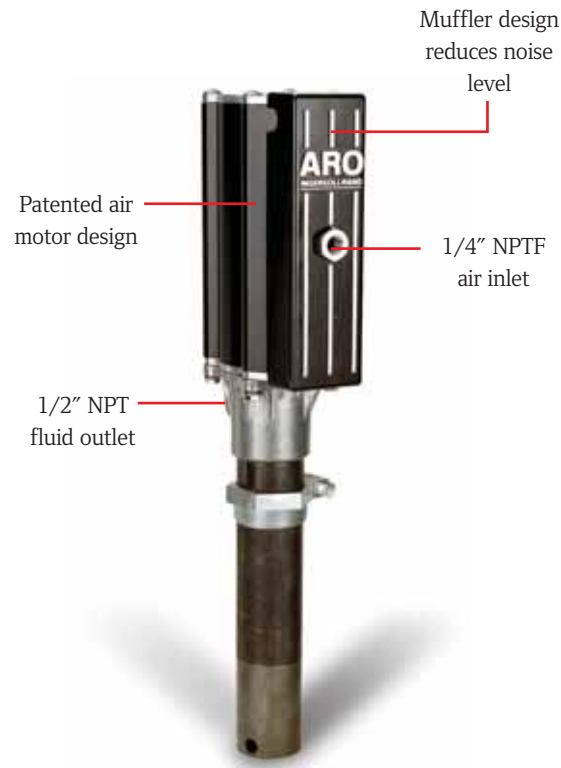

Why Ingersoll Rand / ARO?

Our LM series is ideal for pumping grease, motor oil, gear oil, or transmission fluid. The simple, durable design allows for piston pump service by any owner or qualified technician. Also look for our convenient grease and oil pump packages.

- Flexibility — LM pumps can be serviced in-line and feature a rugged all-weather design (3:1 pumps only)
- Dependability — Valving design uses no trip rods or push pins that usually break
- Durability — Our stall-free, ice-free air motor is contained in a rugged housing
- Commitment — Ingersoll Rand pumps come with a 5-year warranty

In-line service for 3:1 piston pumps

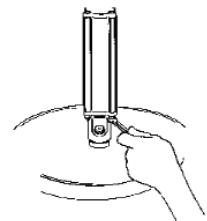

One standard wrench loosens four nuts ...

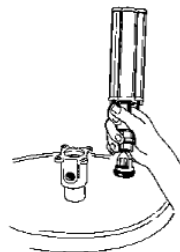

... and allows you to replace all dynamic service kit items (no additional wrenches required for 3:1 pump) ...

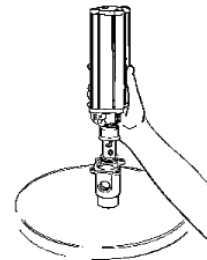

... and put pump back in service in a matter of minutes.

Motor Oil, Gear Oil, Transmission Fluid

Model	Working Flow gpm (L)	Free Flow gpm (L)	Fluid Inlet / Outlet NPTF (mm)	Container Size gal	Air Inlet in (mm)
3:1 PISTON PUMP					
LM2203A-11-C (-12-C = BSP Thread)	6 (23)	9 (34)	3/4" / 1/2" (19 / 13)	Stub	1/4" (6)
LM2203A-31-C (-32-C = BSP Thread)	6 (23)	9 (34)	3/4" / 1/2" (19 / 13)	16	1/4" (6)
LM2203A-41-C (-42-C = BSP Thread)	6 (23)	9 (34)	3/4" / 1/2" (19 / 13)	55	1/4" (6)
LM2203A-51-C (-52-C = BSP Thread)	6 (23)	9 (34)	3/4" / 1/2" (19 / 13)	275	1/4" (6)
5:1 PISTON PUMP					
LM2305A-11-B (-12-B = BSP Thread)	6 (23)	9 (34)	1-1/2" / 1/2" (38 / 13)	Stub	1/4" (6)
LM2305A-31-B (-32-B = BSP Thread)	6 (23)	9 (34)	1-1/2" / 1/2" (38 / 13)	16	1/4" (6)
LM2305A-41-B (-41-B = BSP Thread)	6 (23)	9 (34)	1-1/2" / 1/2" (38 / 13)	55	1/4" (6)
LM2305A-51-B (-51-B = BSP Thread)	6 (23)	9 (34)	1-1/2" / 1/2" (38 / 13)	275	1/4" (6)



Piston Pump Packages

Model	Description	Pump Model	Meter	Control Handle	Dolly	Drum Cover	Hose	Valve
OIL PUMP PACKAGES								
LP2100-1-B	3:1 ratio, 16-gal portable pump package	LM2203A-31-C	635190-1 (pint)	635391-1	640058-2	94421	623501-6	67085
LP2100-2-B	3:1 ratio, 16-gal portable pump package	LM2203A-31-C	635190-3 (Liter)	635391-1	640058-2	94421	623501-6	67085
LP3100-1-B	5:1 ratio, 16-gal portable pump package	LM2305A-31-B	635190-1 (pint)	635391-1	640058-2	94421	623501-6	N/A
LP3100-2-B	5:1 ratio, 16-gal portable pump package	LM2305A-31-B	635190-3 (Liter)	635391-1	640058-2	94421	623501-6	N/A



Industrial-grade Piston Pumps (for oil service)

612041-1

1:1 ratio pump ideal for pumping motor oil, gear oil, and transmission fluid. This model fits a standard 55-gal drum (including bung adaptor).



612042-1

1:1 ratio piston pumps are ideal for moving oils and fluids at high volumes. This model is designed for 275 obround tanks.



662410-B

425 Series pumps are designed with a 9:1 pump ratio, 4-1/4" air motor, and are ideal for pumping heavy oils over long distances.



Model	Working Flow gpm (L)	Free Flow gpm (L)	Air Inlet NPT (F)	Fluid Outlet NPT (F)	Container Size gal	Accessories
PISTON PUMP 1:1 RATIO 2" DIAMETER AIR MOTOR (200 SERIES)						
612041-1	9 (34)	18 (68)	1/4"	3/4"	55	Bung adapter
612041-3	9 (34)	18 (68)	1/4"	3/4"	55	Bung adapter
612042-1	9 (34)	18 (68)	1/4"	3/4"	275	Bung adapter
PISTON PUMP 9:1 RATIO 4 1/4" DIAMETER AIR MOTOR (425 SERIES)						
662420-B	3.9 (14.8)	21 (79.4)	1/4"	3/4"	Stub	
662409	3.9 (14.8)	21 (79.4)	1/4"	3/4"	16	
662410-B	3.9 (14.8)	21 (79.4)	1/4"	3/4"	55	

Piston Pump Accessories

Model	Description	For Use With
5-GAL CONTAINERS		
65986	Siphon tube has 6' long (1.8 m), 3/4" ID hose with 3/4" NPT (M) outlet; hose is neoprene over Thiokol and includes 91020-1 tube.	Wall-mounted stub pumps
55-GAL CONTAINERS		
65986-1	Siphon tube has 6' long (1.8 m), 3/4" ID hose with 3/4" NPT (M) outlet; hose is neoprene over Thiokol.	Drum cover for closed drum w/2-inch bung opening
61601	Speeds 55-gal drum change over. No need to handle pump. Includes 622651-06 hose, Y45-24-C adapter bushing, Y43-5-C street elbow, and 65109 (36" long) carbon steel suction tube; 3/4" NPT(F) fluid outlet.	Wall-mounted stub pumps
66779	For pumping from 55-gal drum. PVC tube has foot valve for positive priming. Includes 76193 bung adapter, adjustable to approximately 35-1/2 inches; 1" NPT (F) fluid outlet.	Stub pumps and diaphragm pumps
61409	For pumping from 55-gal drum. 90° PVC siphon tube, 35-1/2 inches (901.7 mm) long with 2" bung adapter for 55-gal drums. Can easily be cut to desired length, on site; 1/2" NPT (F) outlet.	1/2-inch diaphragm pumps and stub pumps
91020-2	1/2" galvanized suction tube for 55-gal containers; (36" long).	
275-GAL CONTAINERS		
66779-2	For pumping from 275-gal tanks. PVC diaphragm tube has footvalve for positive priming. Includes 76193 bung adapter, adjustable to approximately 48-1/4 inches. 1" NPT (F) fluid outlet.	Stub pumps and pumps



Model	Hose Size ID in	Hose Length ft (m)	Hose Material	Fluid Inlet NPT (M)	Fluid Outlet (NPT)	Used With
SIPHON HOSE, CARBON STEEL FITTINGS						
622701-6	1"	6 (1.8)	Nylon tube with oil-resistant cover	1"	1"	Carbon steel siphon tube
STAINLESS STEEL FITTINGS						
622702-6	1"	6 (1.8)	Nylon tube with oil-resistant cover	1"	1"	Stainless steel siphon tube
622702-10	1"	10 (3)	Nylon tube with oil-resistant cover	1"	1"	Stainless steel siphon tube

Inlet Material Filters

Model	Description	For Use With
651830	Filter element keeps foreign matter from entering lower pump end	Adapts to 91020-1 or -2 pipe extension.
66480	Filter and check valve assembly constructed of 316 stainless steel, assembly has 1" NPT (F) connections and 40-mesh screen; 4-3/4" (121 mm) long x 2-1/8" (54 mm) in diameter	Used with suction tubes when fluid is corrosive and viscosity requires a foot valve for positive priming.

Wall Mount Bracket

Model	Description	For Use With
61113	2" NPT (F) opening for bung-type pumps; bracket can slip over rim of open-head drum or be wall-mounted	55-gal bung-type pumps and 200 Series, Thunder Series and 425 Series stub pumps fitted with bung adapters
66100	Wall-mount bracket has removable mounting plate	425 Series, 4" stroke pumps
66101	Wall-mount bracket has removable mounting plate	425 Series, 6" stroke pumps

Bung Adapters

Model	Description	For Use With
60870	2" (M) for use with 2-1/8" siphon tube	200 Series, 1:1 ratio immersed pumps 425 Series, 9:1 ratio immersed pumps
67145-3-B	2" (M)	Thunder Series, 3:1 oil pumps
67145-4-B	2" (M)	Thunder Series, 5:1 oil pumps
BUNG ADAPTER SEAL KITS		
67088-3	Water-tight seal kit includes 67145-3 bung adapter and 67088 seal kit	Thunder Series 3:1 oil pumps
67088-4	Same as above, except includes 67145-4 bung adapter and 67088 seal kit	Thunder Series 5:1 oil pumps



66480

651830



61113



67145-X



67145-X-B

Grease Pumps

Grease Pumps

Model	Working Flow ppm (kg/min)	Free Flow ppm (kg/min)	Fluid Outlet in (mm)	Container Size (gal)	Air Inlet in (mm)
50:1 PISTON PUMP					
2" DIAMETER AIR MOTOR (3" STROKE)					
LM2250E-21-B (-22 = BSP thread)	2 ppm (1 kg/min)	9 ppm (4 kg/min)	3/8" (9.5)	35 lb	1/4" (6)
LM2250E-31-B (-32 = BSP thread)	2 ppm (1 kg/min)	9 ppm (4 kg/min)	3/8" (9.5)	120 lb	1/4" (6)
LM2250E-41-B (-42 = BSP thread)	2 ppm (1 kg/min)	9 ppm (4 kg/min)	3/8" (9.5)	400 lb	1/4" (6)
LM2250E-61-B (-61 = BSP thread)	2 ppm (1 kg/min)	9 ppm (4 kg/min)	3/8" (9.5)	60 lb	1/4" (6)
3" DIAMETER AIR MOTOR (3" STROKE)					
LM2350E-21-B (-22-B = BSP thread)	4 ppm (2 kg/min)	7.5 ppm (3 kg/min)	3/8" (9.5)	35 lb	1/4" (6)
LM2350E-31-B (-32-B = BSP thread)	4 ppm (2 kg/min)	7.5 ppm (3 kg/min)	3/8" (9.5)	120 lb	1/4" (6)
LM2350E-41-B (-42-B = BSP thread)	4 ppm (2 kg/min)	7.5 ppm (3 kg/min)	3/8" (9.5)	400 lb	1/4" (6)
LM2350E-61-B	4 ppm (2 kg/min)	7.5 ppm (3 kg/min)	3/8" (9.5)	60 lb	1/4" (6)

Grease Pump Packages

Model	Description	Pump Model	Meter	Control Handle	Dolly	Drum Cover	Hose	Follower Plate	Handle	Adapter	Z-Swivel
2" DIAMETER AIR MOTOR											
LP2001-1-B	35 lb grease package	LM2250E-21-B	N/A	N/A	N/A	94420	N/A	640095-2-B	94334	N/A	N/A
LP2002-1-B	35 lb grease package	LM2250E-21-B	N/A	636111	N/A	94420	624201-10	640095-2-B	94334	76493	636077
LP2003-1-B	120 lb grease package	LM2250E-31-B	N/A	N/A	N/A	94421	N/A	640165	N/A	N/A	N/A
LP2004-1-B	120 lb grease package	LM2250E-31-B	N/A	636111	N/A	94421	624201-10	640165	N/A	76493	636077
LP2006-1-B	120 lb grease package	LM2250E-31-B	N/A	636111	640058-2	94421	624201-10	640165	N/A	76493	636077
3" DIAMETER AIR MOTOR											
LP3001-1	35 lb grease package	LM2350E-21-B	N/A	636103	N/A	94420	624201-10	640095-2-B	94334	76493	636077
LP3002-1	120 lb grease package	LM2350E-31-B	622201-3	N/A	N/A	94421	624401-4	640165	N/A	N/A	N/A
LP3003-1	120 lb grease package	LM2350E-31-B	N/A	636103	640057	94421	624201-10	640165	N/A	76493	636077
LP3004-1	120 lb grease package	LM2350E-31-B	N/A	636111	640058-2	94421	624201-10	640165	N/A	76493	636077
LP3005-1	400 lb grease package	LM2350E-41-B	622201-3	N/A	N/A	94422	624401-4	640015-1	N/A	N/A	N/A
LP3007-1	60 lb grease package	LM2350E-61-B	N/A	636111	N/A	71740-1	624401-4	N/A	N/A	N/A	N/A



LP3001-1



LP3003-1

Grease NLGI 0 – 3 lb

Model	Max Per Minute @ 90 psi lb (kg)	Air Inlet NPT in	Fluid Inlet NPP in	Fluid Outlet NPT in	Accessories Included
50:1 PISTON PUMP					
BASIC PUMPS 120-POUND DRUM, 4-1/4" DIAMETER AIR MOTOR (4" STROKE)*					
662402	6 (2.7)	1/2" (F)	Immersed	1/2" (F)	Pump only
400-LB DRUM, 4-1/4" DIAMETER AIR MOTOR (4" STROKE)					
662400-C	6 (2.7)	1/2" (F)	Immersed	1/2" (F)	Pump only
100:1 PISTON PUMP					
BASIC PUMPS 120-LB DRUM, 6" DIAMETER AIR MOTOR (4" STROKE)					
662605**	2.1 (.8)	1/2" (F)	Immersed	1/2" (F)	F/R/L C28241-810
400-LB DRUM, 6" DIAMETER AIR MOTOR (4" STROKE)					
662608**	2.1 (.8)	1/2" (F)	Immersed	1/2" (F)	F/R/L C28241-810

*These pumps are ideal where high pressures are demanded. When higher viscosity lubricants are being pumped, follower plates (page 16) help maintain a good pump prime and continuous material flow.

**WARNING: These 100:1 pumps deliver pressures up to 10,000 psi, which is in excess of the rated capacity of the accessories shown in this catalog. These 100:1 pumps can only be used in permanently installed systems where the pump is connected directly to piping with the proper rating for the application.



Grease Pump Packages

Model	Package Description
HEAVY SERVICE GREASE PUMP PACKAGES	
50:1 RATIO, GREASE, 4-1/4" DIAMETER AIR MOTOR	
612721	400-lb grease package includes 662400-C pump, 621501-05 air hose (5'), 624401-8 material hose (8'), 4148 bung adaptor (order follower plate 640015-2 when required)
612805	400-lb grease package includes 662400-C pump, L26241-110 air lubricator, 621501-05 air hose (5'), 624401-8 material hose (8'), and 60898 drum cover (order follower plate 640015-2 when required)
100:1 RATIO, GREASE, 6" DIAMETER AIR MOTOR	
662606*	120-lb grease package includes 662605 pump, C28241-810 air filter / Regulator / Lubricator, 66715 drum cover, and 640152-1 follower plate
662609*	400-lb grease package includes 662608 pump, C28241-810 air filter / Regulator / Lubricator, 71060-1 drum cover, 60870 bung adapter, and 640015-5 follower plate

*WARNING: These 100:1 pumps deliver pressures up to 10,000 psi which is in excess of the rated capacity of the accessories shown in this catalog. These 100:1 pumps can only be used in permanently installed systems where the pump is connected directly to piping with the proper rating for the application.



Grease Pump Accessories

High-pressure Wash and Tire-Fill Pump Package

Model	Ratio	Max Per Minute gal (L)	Cycles Per gal (L)	cu in (L) Per Cycle	Packings Type / Material Upper Lower	Fluid Inlet	Fluid Outlet NPT in	Air Inlet NPT in
BASIC PUMPS								
STUB 4-1/4" DIAMETER AIR MOTOR / 4" STROKE								
613100-1	10:1	3.9 (14.8)	21 (5.5)	11 (0.18)	Buna N Buna N	Barbed	3/8" (F)	1/2" (F)

High-power cleaning solutions

- Perfect for cleaning:**
- Cars and trucks
 - Engines
 - Construction equipment
 - Aircraft
 - Farm equipment
 - Plant structures
 - Railroad equipment
 - Fleet vehicles
- with the application of:**
- Degreasers
 - Detergents
 - Cleaning solutions
 - Water
 - Metal brighteners
 - Aluminum brighteners

Model	Description
SPRAY WASH PUMP PACKAGE	
613104	4-1/4" High-pressure wall-mounted spray package includes 613100-1 pump, 61113 wall bracket, 61139-1 55-gal suction tube assembly, 622427-40 material hose (40'), 641523 control handle, 61133 spray wand, TP6250-18 spray tip and L26241-010 Air Line lubricator



Dollies, Hand Trucks

Model	Description
DOLLIES	
16-GAL DRUM	
640057	Platform-type dolly has four swivel casters and three drum clamps; for use with steel or fiber drums
640058-2	Band-type dolly has four rubber-wheeled casters and screw clamp; for use with steel or fiber drums
HAND TRUCKS	
16-GAL DRUM	
640062	Two-wheel truck has clamp rod and two base supports to hold drum; wheels are rubber
640149	Three-wheel truck includes hinged handle, swivel-type front wheel, and two 6" rubber rear wheels



Bung Adapters

Model	Description	For Use With
BUNG ADAPTERS		
4148	2" (M) for use with 1-7/8" siphon tube	425 Series, 50:1 ratio grease pumps
67145-1	2" (M)	Thunder Series, 60:1 grease pumps
67145-2	2" (M)	Thunder Series, 50:1 grease pumps
BUNG ADAPTER SEAL KITS		
67088	Water-tight seal for use outdoors	Thunder Series



67145-X

Drum Covers

Model	Description	For Use With
5 GAL / 35-LB PAIL		
94420	Has 2" NPT (F) bung opening and three hold-down screws (fits 10.23" - 12" OD drums)	Thunder Series 5-gal pumps
16 GAL / 120-LB DRUM		
66492	Has pump opening, mounting holes, and tie-down brackets; order tie-down rods separately (fits 12.75" - 15" OD Drums)	Models 662402 and 662409
94421	Has 2" NPT (F) bung opening and three hold-down screws (fits 13-1/8" - 14-7/8" OD drums)	Thunder Series 16-gal / 120 lb bung pumps
55 GAL / 400-LB DRUM		
71060-1	Has 2" NPT (F) bung opening and tie-down brackets; order tie-down rods separately (fits 20" - 24-5/8" OD drums)	200 Series and 425 Series, 55-gal / 400-lb bung-type
94422	Has 2" NPT (F) bung opening and three hold-down screws; bung pumps (fits 21-7/8" - 23-5/8" OD drums)	55-gal drum cover models LM2250E-41-B and LM2350E-41-B



94420

94421

71060-1

94422

Cover Tie-down Rods

Model	Description	For Use With
16-GAL / 120-LB DRUM		
640164	Tie-down bracket kit fixes / holds down drum cover. Includes brackets, rods, mounting hardware. Use with 94421 Cover.	Thunder Series pumps.
640091	Set of two tie-down rods and mounting brackets. Use with 66492 Cover.	Series 200 and 425, 16-gal / 120-lb drum covers
55-GAL / 400-LB DRUM		
71027-1	Set of two tie-down rods and mounting brackets. Use with 71060 cover.	Thunder Series, also 200 and 425 Series, 55-gal /400-lb drum covers

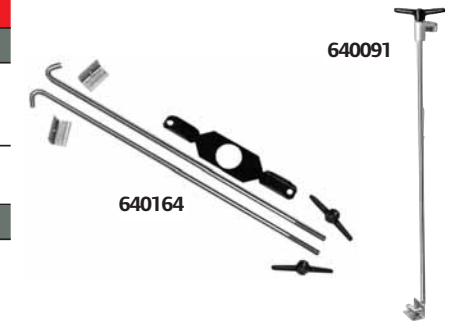

640164

640091

Pumps Lifts

Model	Description	For Use With
SINGLE-POST LIFT		
640225	Air-operated lift for 16 gal / 120# container size. Extended height 62 in (1.6 m). Suggested drum cover 94421.	Thunder Series LM2250E-31-B LM2350E-31-B LM2305A-31-B
640067	Single-acting cylinder for easy 55-gal /400-lb drum change-over. Requires 71060-1 drum cover. Extended height 92 in (2.3 m).	425 Series, Thunder Series



640225

640067

Follower Plates

Model	Wiper Seal Material	OD of Pump Tube To Be Fitted	For Use With
35-LB TAPERED PAIL (FITS 10" - 11" ID DRUMS)			
640095-1-B	Rubber	1"	Thunder Series 60:1
640095-2-B	Rubber	1-1/2"	LM2250E-21-B, LM2350E-21-B
640095-3-B	Rubber	2"	Hand pumps
120-LB DRUM (FITS 13" - 14" ID DRUMS)			
640027	Buna-N	2"	Hand pumps
640152	Buna-N	1-7/8"	425 Series, 50:1
640152-1	Buna-N	2-1/8"	600 Series, 100:1
640165	Buna-N	1-1/2"	LM2250E-31-B, LM2350E-31-B
400-LB DRUM (FITS 20" - 23" ID DRUMS)			
640015-2	Buna-N	1-7/8"	425 Series, 50:1
640015-5	Buna-N	2-1/8"	600 Series, 100:1
640015-1	Buna-N	1-1/2"	LM2250E-41-B, LM2350E-41-B



640095-2-B

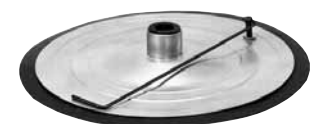

640015-1

Diaphragm Pumps

3/8" to 2" Fluid Ports

Features and benefits

■ Ideal for abrasion and solids-handling

Because it does not use rotating, sliding seals, like rotary / centrifugal pumps, more process engineers look to Ingersoll Rand / ARO diaphragm pumps for handling tough abrasion applications.

■ Bolted construction for safe reliability and ease of assembly

All Ingersoll Rand / ARO diaphragm pumps use bolted construction that process professionals demand. And, Ingersoll Rand / ARO Non-metallic diaphragm pumps utilize fasteners that are constructed of 300 Series stainless steel for maximum chemical resistance.

Bolted is safer — Bolted construction reduces the risk of spills and environmental contamination, and the attendant, mandatory reports to regulatory agencies that spills can create.

Bolted is reliable — Bolted construction withstands the heavy loading that diaphragm pumps are subjected to, without concerns of breakage or loosening.

Bolted is easier to assemble — Our bolted design allows for easy positioning and alignment of parts during reassembly. This is a significant advantage over band-clamp style pump fasteners, which are difficult to align and hold together during reassembly.

Bolted is less expensive — This design uses standard bolts that cost significantly less to replace. Non-standard fastening devices (such as band clamps) are considered wear parts and are more expensive to replace.

■ Positive priming provides instant start-ups

Check valves are located close to the diaphragm chambers, ensuring a positive prime the first time, every time.

■ Ingersoll Rand / ARO patented unbalanced air valve

Ingersoll Rand / ARO unbalanced air valve design makes this, and all Ingersoll Rand / ARO diaphragm pumps unstickable. Because the unbalanced valve cannot settle in a neutral position when the pump is shut down, it can't become stuck, requiring the operator to hammer on the pump in order to start up again.

- Eliminates shifting / freezing problems
- Uses significantly less power than competition
- Does not require lubrication
- Forgiving in dirty air

■ Broad material selection

Ingersoll Rand / ARO offers a wide selection of materials, allowing your choice of the best possible wetted and non-wetted materials suited to your application.

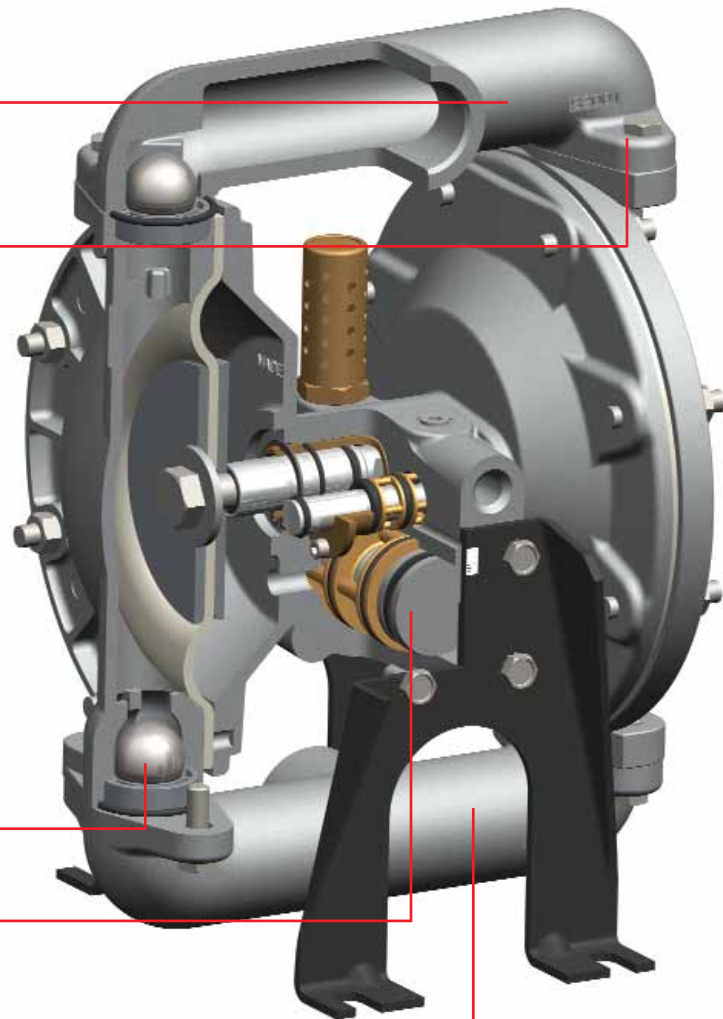

Why Ingersoll Rand / ARO?

Our diaphragm pumps are ideal for pumping oil or other light fluids such as anti-freeze, water, windshield fluid, fuel, (See UL 79 Approved Units) solvents, transmission fluid, and waste oil. Fluid ports for Ingersoll Rand / ARO diaphragm pumps range in size from 3/8" to 2" to meet the requirements of any application.

- Safety — Bolted fasteners prevent fluid leaks harmful to workers and the environment
- Reliability — Unbalanced valve design eliminates valve centering and pump stall-outs, even under low air inlet pressure
- Durability — Diaphragms provide four times the life over competitors
- Flexibility — Variety of body materials allow you to pump different fluids
- Commitment — Ingersoll Rand / ARO diaphragm pumps come with a five-year warranty

These items available through Pro-Series offering.

Model	Body Materials (wetted)	Diaphragm / Ball Material	Air Inlet NPT (F) in	Fluid Inlet / Outlet Material in	Max Flow gpm	Compatible Fluids	Replaces Model
3/8" PORTS							
PD03P-ARS-PTT	Polypropylene	Teflon	1/4"	3/8" / 3/8"	10.6	Windshield fluid, motor / gear oil, transmission fluid, anti-freeze	New
PD03P-ARS-PCC	Polypropylene	Hytrel	1/4"	3/8" / 3/8"	10.6	Windshield fluid, motor / gear oil, transmission fluid, anti-freeze	New
PD03P-AES-DTT	Acetal (groundable)	Teflon	1/4"	3/8" / 3/8"	10.6	Solvents	New
PD03P-AES-DCC	Acetal (groundable)	Hytrel	1/4"	3/8" / 3/8"	0.6	Windshield fluid, motor / gear oil, transmission fluid, anti-freeze	New
1/2" PORTS							
PD05P-ARS-PTT-B	Polypropylene	Teflon	1/4"	1/2" / 1/2"	14.4	Windshield fluid, motor / gear oil, transmission fluid, anti-freeze	66605J-344*
PD05P-ARS-PCC-B	Polypropylene	Hytrel	1/4"	1/2" / 1/2"	14.4	Windshield fluid, motor / gear oil, transmission fluid, anti-freeze	66605J-322*
PD05P-ARS-PAA-B	Polypropylene	Santoprene	1/4"	1/2" / 1/2"	14.4	Windshield fluid / anti-freeze	66605J-388*
PD05P-AES-DTT-B	Acetal	Teflon	1/4"	1/2" / 1/2"	14.4		666056-6A4*
PD05P-AES-DCC-B	Acetal	Hytrel	1/4"	1/2" / 1/2"	14.4	Windshield fluid, motor / gear oil, transmission fluid, anti-freeze	66605H-622*
66605J-344*	Polypropylene	Teflon	1/4"	1/2" / 1/2"	13	Windshield fluid, motor / gear oil, transmission fluid, anti-freeze	
66605J-322*	Polypropylene	Nitrile	1/4"	1/2" / 1/2"	13	Windshield fluid, motor / gear oil, transmission fluid, anti-freeze	
66605J-388*	Polypropylene	Polyurethane	1/4"	1/2" / 1/2"	13	Windshield fluid, motor / gear oil, transmission fluid, anti-freeze	
1" PORTS							
666100-344-C	Aluminum	Teflon	1/4"	1" / 1"	35	Windshield fluid, motor / gear oil, transmission fluid, anti-freeze, solvents	
666100-3C9-C	Aluminum	Hytrel	1/4"	1" / 1"	35	Windshield fluid, motor / gear oil, transmission fluid, anti-freeze	
666100-322-C	Aluminum	Buna	1/4"	1" / 1"	35	Windshield fluid, motor / gear oil, transmission fluid, anti-freeze	
650717-C	Aluminum	Viton / Acetal	1/4"	1" / 1"	29	Fuel (UL 79 approved)	
1-1/2" PORTS							
666150-362-C	Aluminum	Nitrile / Acetal	1/2"	1-1/2"	90	Windshield fluid, motor / gear oil, transmission fluid, anti-freeze	
650718-C	Aluminum	Viton / Acetal	1/2"	1-1/2"	75	Fuel (UL 79 approved)	
2" PORTS							
666250-9C9-C	Aluminum	Hytrel	3/4"	2"	172	Windshield fluid, motor / gear oil, transmission fluid, anti-freeze	
650719-C	Aluminum	Viton / Acetal	3/4"	2"	105	Fuel (UL 79 approved)	

*These pumps have been superseded and will be discontinued in the near future. See recommended replacements above.

Specialty Application Pumps Specifications

These items available through Pro-Series offering.

Model	Application	Manifold Material	Diaphragm, O-Ring Material	Air Inlet NPT / F in (mm)	Fluid Outlet NPT / F in (mm)	Max gpm (L/min)	Package Includes
1/2" PORTS							
612999-5	Waste oil evacuation	Polypropylene	Nitrile	1/4" (6)	1/2" (13)	11 (42)	Wall mount, inlet and outlet fluid hoses
612999-6	Waste oil evacuation	Polypropylene	Nitrile	1/4" (6)	1/2" (13)	11 (42)	Hanging bracket and outlet hose
670042	Fuels	Aluminum	Viton	1/4" (6)	1/2" (13)	12 (45.4)	Pump only
1" PORTS							
650715-C	50 / 50 mix of anti-freeze and water	Aluminum	Nitrile	1/4" (6)	1" (25)	35 (133)	Pump only
612999-3	50 / 50 mix of anti-freeze and water	Aluminum	Nitrile	1/4" (6)	1" (25)	35 (133)	Wall mount, siphon tubes, material hoses
612999-4	Waste oil evacuation	Aluminum	Nitrile	1/4" (6)	1" (25)	35 (133)	Wall mount, inlet and outlet fluid hoses
613201-2-C	Calcium chloride tire filling	Aluminum	Neoprene	1/4" (6)	1" (25)	35 (133)	Inlet and outlet hoses, strainer, 8' suction hose, control handle, check valve

650715-C Fuel Pump (1" NPTF Outlet)

This 1:1 ratio pump (650715-C) has dual inlets to allow simultaneous pumping and blending of antifreeze and water.



Calcium Chloride Tire-fill Pump Package

613201-2-C Calcium Chloride Tire-fill Pump Package

Designed for the purpose of evacuating and filling tires with calcium chloride ballast solution. Package includes a 666100-441-C, 1" port diaphragm pump. Aluminum construction with neoprene diaphragms and Teflon® checks for compatibility with corrosive calcium chloride and 60154 hose / strainer / gun assembly. Also includes check valve and all required clamps and related hardware.



Pro-Series Pumps

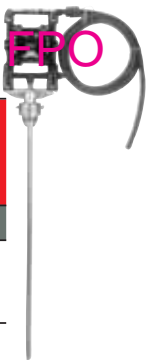

Ratio	Max Flow gpm (L/min)	Displacement per cycle gal (L)	Air Inlet NPT / F in (mm)	Fluid Inlet NPT	Fluid Outlet NPT / F	Max Operating Pressure psi (bar)	Suspended Solids Max Diameter in (mm)	Shipping Weight lb (kg)
1:1 RATIO DRUM PUMP PERFORMANCE SPECIFICATIONS								
1:1	11 (41.6)	.039 (.15)	1/4 - 18	Siphon Tube for 55-gal Drum	1/2 - 14	100 (6.8)	3/32" (2.4)	22 (10) Polypropylene, basic package 26 (11.8) Aluminum, basic package 36 (16.3) Stainless, basic package

Drum Pumps

Choose from aluminum, stainless steel or polypropylene body construction – ARO Drum Pumps are available in three body materials for optimum fluid compatibility.

Drum Pump Packages

Package Components Factory-Matched – ARO Drum Pump package components contain pre-specified, matching materials of construction for complete fluid compatibility

Drum Pump Packages can be ordered in 3 styles:

- Basic: Pump, bung adapter, air safety shut-off, siphon tube, weather seal and base
- Complete / Transfer: basic pump plus fluid hose or fluid hose with non-drip nozzle
- Complete / Dispensing: basic pump plus foot valve, hose and dispensing nozzle

Pump Features

- 11-gpm flow capability: drum pumps offer plenty of capacity to satisfy a broad range of transfer application volume demands
- Stall-free operation: ARO diaphragm drum pumps feature a patented unbalanced air valve design that avoids stall-out, even under low air-inlet pressures
- Bolted construction: ARO diaphragm drum pumps utilize bolted fasteners for leak-tight integrity
- 5-year Warranty

Model	Pump Housing And Seats	Pump Dia. And Balls	Lock Out Valve (P/N 104253-2)	Foot Valve	10' Hose ASM	Dispense Valve	Fluid Service
DAB05-PPTT-2-A	Polypropylene	PTFE (Teflon)	X	-	-	-	Acids & Caustics
DAB05-PPCC-2-A	Polypropylene	Hytrel	X	-	-	-	Oil
DAB05-PPUU-2-A	Polypropylene	Polyurethane	X	-	-	-	Water / Oil
DAB05-PPAA-2-A	Polypropylene	Santoprene	X	-	-	-	Mild Acids / Mild Caustics
DAB05-PPCC-2-N	Polypropylene	Hytrel	X	-	Nitrile	-	Oil
DAB05-PPCC-B-M	Polypropylene	Hytrel	X	X	Nitrile	No-drip	Oil
DAB05-PPAA-2-B	Polypropylene	Santoprene	X	-	EPDM	-	Mild Acids / Mild Caustics
DAB05-PPUU-2-C	Polypropylene	Polyurethane	X	-	Vinyl	-	Water / Oil
DAB05-PPCC-B-J	Polypropylene	Hytrel	X	X	Reinforced Nitrile	X	Oil
DAB05-PPAA-B-K	Polypropylene	Santoprene	X	X	EPDM	X	Mild Acids / Mild Caustics
DAB05-SSTT-2-A	Stainless Steel	PTFE (Teflon)	X	-	-	-	Solvent
DAB05-ASTT-2-A	Alum./SS.	PTFE (Teflon)	X	-	-	-	Solvent
DAB05-APCC-2-A	Alum./Poly.	Hytrel	X	-	-	-	Oil / Some Solvents
DAB05-APCC-2-O	Alum./Poly.	Hytrel	X	-	Nitrile	-	Oil / Some Solvents
DAB05-APCC-B-P	Alum./Poly.	Hytrel	X	X	Nitrile	No-drip	Oil / Some Solvents
DAB05-APCC-B-D	Alum./Poly.	Hytrel	X	X	-	X	Oil / Some Solvents
DAB05-APCC-B-L	Alum./Poly.	Hytrel	X	X	Reinforced Nitrile	X	Oil /Some Solvents
DAB05-ASAA-2-A	Alum./S.S.	Santoprene	X	-	-	-	Water

Natural Gas Driven Diaphragm Pumps

From ARO, the world-leader in stall and ice-free pump technology, comes three new natural gas driven diaphragm pump models. Introducing the new CSA Certified diaphragm pumps. CSA (Canadian Standards Association) is internationally known for standards and certification of equipment that is powered by natural gas. These pumps are the ideal answer to fluid handling operations in remote locations, such as oil and gas facilities, where sweet natural gas is an available energy source. Combined with ARO's patented valve technologies, these gas-driven pumps have the wetted and body materials to deliver superior fluid compatibility and performance in a portable package.

Features

- Ice-free, stall-free operation
- Bolted construction for leak-tight material integrity
- All-metal construction
- Flows up to 133 LPM
- Lube-free operation
- Grounding strap included with pump
- Ported exhaust
- 5-year warranty
- CSA Certified: meets the CSA U.S. / International requirement No. 2.01 for natural gas operated diaphragm pumps

Model	Ratio	Max Flow gpm (L/min)	Displacement per cycle gal (L)	Gas Inlet Female NPT / F	Fluid Inlet NPT / F	Fluid Outlet NPT / F	Exhaust Port NPT	Max Operating Pressure psi (bar)	Suspended Solids Max Diameter in (mm)	Weight lb (kg)	Max Dry Suction Lift ft (m)
1/2" PORTS											
PG05A-AAS-FGG-B	1:1	12.0 (45.4)	0.039 (0.15)	1/4 - 18	1/2 - 14	1/2 - 14	3/8-18	100 (6.9)	3/32" (2.4)	10.4 (4.7)	9.1 (2.8)
1" PORTS											
6661H0-1C9-C	1:1	35 (133)	0.16 (0.60)	1/4 - 18	1 - 11-1/2	1 - 11-1/2	3/8-18	120 (8.3)	1/8" (3.2)	19 (8.6)	20 (6.1)



PG05A-AAS-FGG-B



6661H0-1C9-C



Grounding strap included with pump

Diaphragm Pump Accessories

55-gal drum bung adapter kits

Kit contains base, bung adapter, bung seal, siphon tube, weather seal, and hardware.

Model	Base Material	Tube Material	Weather Seal	Base Seal
67231	Polypropylene	Polypropylene	UHMW PE	Viton
67231-6	Aluminum	Stainless Steel	Viton	Viton
67231-7	Stainless Steel	Stainless Steel	Viton	Viton

Note: Fasteners are 300 Series Stainless Steel

Bulk tank adapter kits

Kit contains base, threaded adapter, and hardware.

67234 Polypropylene / Viton O-ring seal

67234-7 300 series stainless steel



67234
Tank Adapter

Foot valves

Recommended for use with dispensing nozzle. Assembly includes housing, ball check, and O-ring.

637336 Polypropylene with Viton O-ring and ball. Use with 67231.

637337 Stainless steel with Viton O-ring and ball. Use with 67231-6 or 67231-7.



Drum adapter kit



637336
Foot valve

Hose

1/2" ID hose comes in 10-foot lengths.

Model	Material	For Use With	Fittings End / End	Dispensing Nozzle Used With (order separately)
621517-10	Nitrile	Polypropylene	Cam / bare	N/A
621516-10	Nitrile	Polypropylene	Cam / brass 1/4"-18 NPT male	635129
621523-10	Nitrile	Polypropylene	Cam / non-drip nozzle	N/A
621515-10	EPDM	Polypropylene	Cam / bare	N/A
621519-10	Vinyl	Polypropylene	Cam / bare	N/A
621514-10	EPDM	Polypropylene	Cam / 1" NPT	95199
622514-10	Nylon	Polypropylene	1/2" NPT / 1/2" NPT 316 stainless steel	
621518-10	Nitrile	Aluminum	Cam / bare	N/A
621520-10	Nitrile	Aluminum	Cam / brass 1/4"-18 NPTF	635129
621524-10	Nitrile	Aluminum	Cam / non-drip nozzle	N/A

Note: Hose requires 95189 to adapt to 1/2" port.

Fluid Dispensing Nozzles

Model	Description	
95199	Composite Nozzle	High-flow nozzle works like gasoline nozzle; features tough composite (polypropylene) construction for caustic service
95200	Swivel	1" (M) X 1" NPT (F) Polypropylene hose swivel attaches between hose and dispensing nozzle and allows operator to rotate freely; use with 95199
95183	Oil Tapper	Easy-pull tapper attaches directly to pump outlet port and provides even flow dispensing; aluminum construction for oil service
77617	Oil Tapper Fitting	Plated carbon steel 1/2"-14 NPTF x 3/8"-18 NPTF -1; used to attach 95183 oil tapper to 1/2" aluminum pump
635129	Bibb with Trigger	1/4" NPT(F) inlet, zinc die casting with brass, and nitrile seals for water or oil service; radiator-type bibb has 1/4" fluid inlet and non-drip tip



621514-10, 95200, 95199
Hose, swivel, and dispensing nozzle



621516-10
635129
Hose and dispensing bibb



621523-10
Hose and non-drip nozzle

Pump Outlet Adapter

95189 Composite Fitting - 1/2" NPT (in) x MaleCam adapter (polypropylene)

95190 Aluminum Fitting - 1/2" NPT (in) x MaleCam adapter (aluminum)

Suction Tubes

Model	Description	Pumps Used With
SUCTION TUBES		
91020-1	1/2" galvanized suction tube for 5-gal containers; 16" long	1/2" diaphragm pumps
55-GAL		
65986-1	Siphon tube has 6' long, 3/4" ID hose with 3/4" NPT (M) outlet; hose is Neoprene over Thiokol	Drum cover for closed drum with 2" bung opening
66779	For pumping from 55-gal drum; PVC tube has foot valve for positive priming; includes 76193 bung adapter, adjustable to approximately 35-1/2"; 1" NPT (F) fluid outlet	Stub pumps and diaphragm pumps
61409	For pumping from 55-gal drum; 90° PVC siphon tube, 35-1/2" long with 2" bung adapter for 55 gal drums that can easily be cut to desired length on site; 1/2" NPT (F) outlet	1/2" diaphragm pumps and stub pumps
275-GAL CONTAINERS		
61412-1	For pumping from 275-gal tank; Threads directly into pump inlet, includes 2" bung adapter 45-1/2" long; schedule 80 PVC pipe can easily be cut to desired length on site; 1/2" NPT (M) fluid outlet	1/2" diaphragm pump



Wall-mount Bracket

Model	Description	Pumps Used With
DIAPHRAGM PUMPS		
76763	Wall-mount bracket allows pump to be located convenient to container	1/2" diaphragm pumps
66100	Wall-mount bracket has removable mounting plate	1" diaphragm pumps
62133	Wall-mount bracket	1-1/2" diaphragm pumps



Hose Reels

6358 Low-pressure Heavy-duty Reel

This new composite hose reel provides excellent durability at a great value. All composite reels are made of a tough glass-filled composite material combined with a strong steel base.



Model	Performance Rating	Max Pressure psi	Hose Length ft	Hose ID in	Inlet / Outlet NPT in	Dimensions Length in	Width in	Height in	Spool Material	Use
LOW-PRESSURE HOSE REELS										
6332	Heavy-duty	300	35	1/2"	3/8" / 1/2"	17.75"	7"	20.37"	Composite	Air, water, compatible solvents
6338	Heavy-duty	300	35	3/8"	3/8" / 3/8"	17.75"	7"	20.37"	Composite	Air, water, compatible solvents
6358	Heavy-duty	300	50	3/8"	3/8" / 3/8"	17.75"	7"	20.37"	Composite	Air, water, compatible solvents, nitrogen
6358G	Heavy-duty	300	50	3/8"	3/8" / 3/8"	17.75"	7"	20.37"	Composite	Air, water, compatible solvents, nitrogen
MEDIUM-PRESSURE HOSE REELS										
6432	Heavy-duty	2000	35	1/2"	1/2" / 1/2"	17.75"	7"	20.37"	Composite	Oil, anti-freeze

Note: All models supplied with hose.

Ultra-duty Hose Reels

Fully redesigned with you in mind

The Ingersoll Rand / ARO ultra-duty hose reels offer improved strength and durability in a hose reel design. The versatile guide arm adjusts for convenient wall, floor, and ceiling mounting positions. Models are available for air, water, oil, and fluid service. The Safety-Reel™ design (SR models) features a controlled retraction mechanism to reduce property damage and improve operator safety.

Features and benefits

- Spun steel disc design for added strength and durability
- Containerized spring motor for fast and convenient maintenance
- Solid steel axle with precision bearings for smooth rotation
- Safety-Reel models feature 80% slower retraction to reduce property damage and improve operator safety

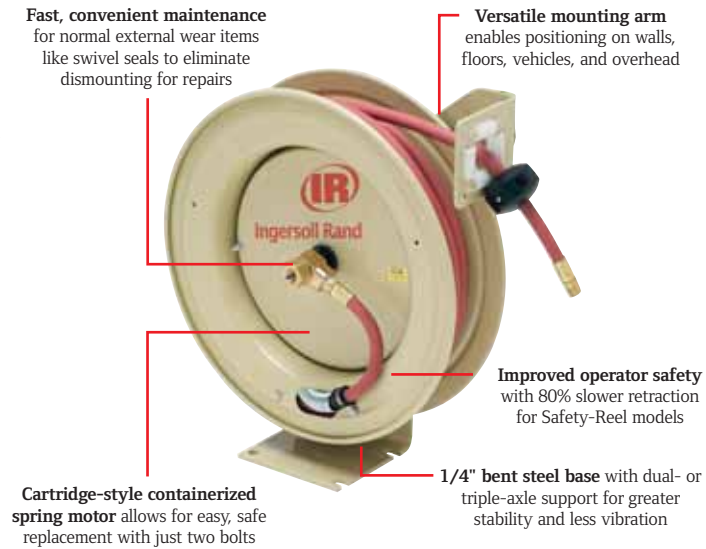

Model	Hose ID in (mm)	Inlet / Outlet NPT in (mm)	Length ft (m)	psi (bar)	Weight lb (kg)
ULTRA-DUTY					
LOW-PRESSURE — AIR / WATER					
7UL3035	3/8" (9)	3/8" (9)	35' (11)	300 (21)	38 (17)
7UL3050	3/8" (9)	3/8" (9)	50' (15)	300 (21)	43 (20)
7UL3050-SR	3/8" (9)	3/8" (9)	50' (15)	300 (21)	43 (20)
7UL4030	1/2" (13)	1/2" (13)	30' (9)	300 (21)	45 (20)
7UL4050	1/2" (13)	1/2" (13)	50' (15)	300 (21)	48 (24)
7UL4050-SR	1/2" (13)	1/2" (13)	50' (15)	300 (21)	48 (24)
MEDIUM-PRESSURE — OIL / FLUID					
7UM4025	1/2" (13)	1/2" (13)	25' (8)	2,500 (172)	49 (23)
7UM4025-SR	1/2" (13)	1/2" (13)	25' (8)	2,500 (172)	49 (23)
7UM4050	1/2" (13)	1/2" (13)	50' (15)	2,500 (172)	67 (30)
7UM4050-SR	1/2" (13)	1/2" (13)	50' (15)	2,500 (172)	67 (30)
HIGH-PRESSURE — GREASE					
7UH3025	3/8" (9)	3/8" (9)	25' (8)	4,000 (276)	49 (22)
7UH3025-SR	3/8" (9)	3/8" (9)	25' (8)	4,000 (276)	49 (22)
7UH3050	3/8" (9)	3/8" (9)	50' (15)	4,000 (276)	65 (30)
7UH3050-SR	3/8" (9)	3/8" (9)	50' (15)	4,000 (276)	65 (30)

Note: All models supplied with hose.

Supreme-duty Hose Reels

Fully redesigned with you in mind

The supreme-duty series is designed for vehicle or heavy-duty applications requiring extra life and enhanced durability. The dual pedestal design offers triple-axle support points for improved strength and stability. Models are available for air, water, and fluid service. The Safety-Reel design features a controlled retraction mechanism to reduce property damage and to improve operator safety.

Features and benefits

- Offers triple axle support
- Dual-pedestal design excellent for vehicle applications
- Spun steel disc design for added strength and durability
- Safety-Reel feature 80% slower retraction to reduce property damage and improve operator safety
- Adjustable guide arm for wall, floor, and ceiling mounting positions

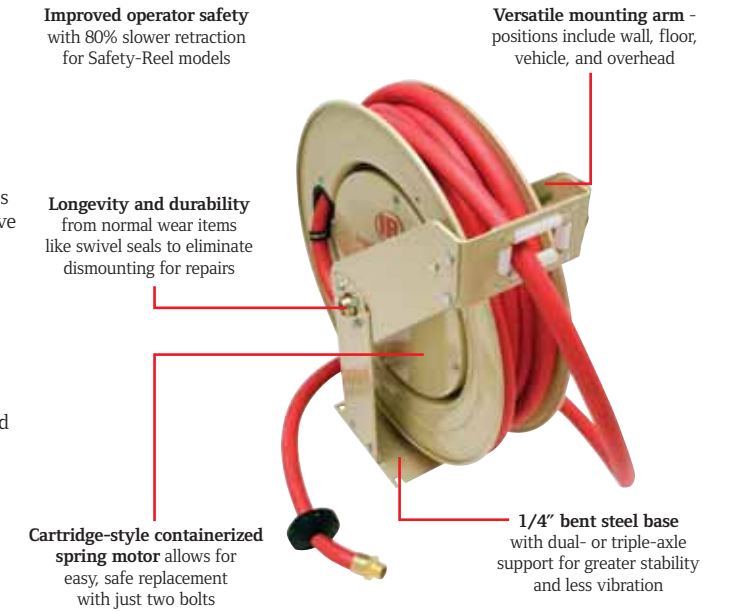

Model	Hose ID in (mm)	Inlet / Outlet NPT in (mm)	Length ft (m)	psi (bar)	Weight lb (kg)
SUPREME-DUTY					
LOW-PRESSURE — AIR / WATER					
7SL3050-SR	3/8" (9)	3/8" (9)	50' (15)	300 (21)	61 (28)
7SL3075-SR	3/8" (9)	3/8" (9)	75' (23)	300 (21)	82 (37)
7SL4050-SR	1/2" (13)	1/2" (13)	50' (15)	300 (21)	63 (29)
7SL4075-SR	1/2" (13)	1/2" (13)	75' (23)	300 (21)	82 (37)
MEDIUM-PRESSURE — OIL / FLUID					
7SM4050-SR	1/2" (13)	1/2" (13)	50' (15)	2,500 (172)	77 (35)
HIGH-PRESSURE — GREASE					
7SH1100-SR	1/4" (6)	1/4" (6)	100' (30)	5,000 (345)	104 (47)

Note: All models supplied with hose.

Auxiliary Reels

Power cord reels

- 50' x 16-gauge AWG cord for electrical applications up to 13 amps (115 volts)
- Features an optional fluorescent angle light with tool tap plug
- Available with a single industrial-type 3-prong receptacle (115 volts)
- Safety-Reel™ feature 80% slower retraction to reduce property damage and improve operator safety
- Adjustable guide arm for wall, floor, and ceiling mounting positions



Option A



Option D

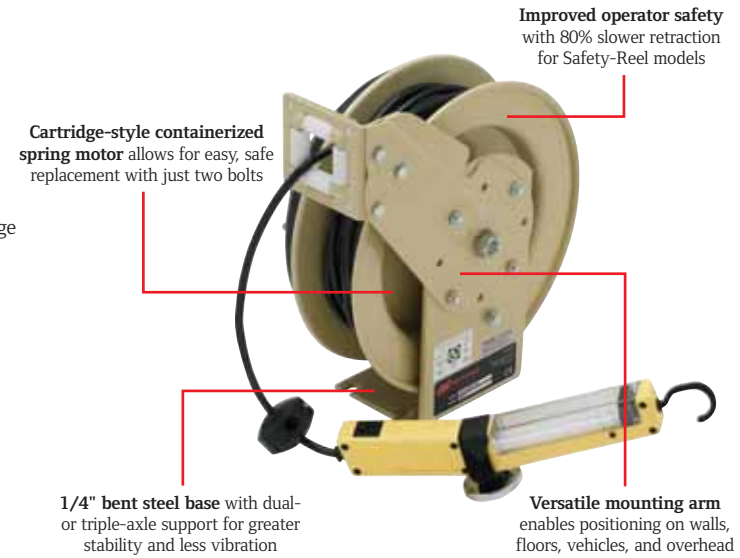

Model	AWG Rating	Max Rating amps	Voltage Rating volts	Length ft (m)	Weight lb (kg)	Notes
AUXILIARY REELS						
ELECTRIC CORD						
7E16050A-SR	16 GA	13	115	50' (15)	36 (16)	Comes with plug
7E16050D-SR	16 GA	13	115	50' (15)	37 (17)	Comes with light

Note: All models supplied with hose.

Mounting Accessories for Hose Reels



Accessory	Model	Compatible With	Features
Overhead mounting bracket	IR-7001	Ultra-duty and electric cord reel	Overhead mounting bracket for I or H beam, 5" x 6" flange
Overhead mounting bracket	IR-7009	Supreme-duty	Overhead mounting bracket for I or H beam, 8" x 9" flange
Wall-mount swing bracket	IR-7002	Ultra-duty and electric cord reel	180° swing bracket for vertical mounting
Floor-mount swivel bracket	IR-7003	Ultra-duty, supreme-duty, electric cord reel	345° swivel bracket for horizontal mounting
Ceiling-mount bracket, required with IR-7005	IR-7004	Ultra-duty, electric cord reel	Easy installation bracket, reel slides in and out for easy overhead mounting; must be ordered with IR-7005 for I or H beam installation
I or H beam adapter, requires IR-7004	IR-7005	Ultra-duty, electric cord reel	Easy installation bracket, I or H beam adapter; must be ordered with IR-7004.
Wall-mount swing bracket	IR-7006	Supreme-duty	180° vertical mounting bracket; powder-coated crinkle black
Reelcraft adapter plate	IR-7007		Custom adapter bracket for Reelcraft models 4000, 5000, 5806, and 7000 Series; 3" x 5" and 4" x 5" base patterns
Graco adapter plate	IR-7008		Custom adapter bracket for Graco 500 Series 3" x 5" and 4" x 5" base patterns

Control Handles

Non-metered Fluid Control Handles

Model	Description	Max working Pressure psi (bar)	Fluid Inlet NPT (F) in	Fluid Outlet
MOTOR OIL, GEAR OIL, TRANSMISSION FLUID				
HIGH-VOLUME				
635193	Has flexible rubber hose with non-drip nozzle; use with 1:1 and 3:1 pumps; Non-drip tip	600 (41)	3/4"	629212
635395-2	Has flexible rubber hose with non-drip nozzle; use with 5:1 and 9:1 pumps; non-drip tip	900 (63)	3/4"	629212
STANDARD-VOLUME				
635392	Has flexible rubber hose, built-in swivel and filter, and non-drip nozzle; non-drip tip	1,000 (69)	1/2"	60164
635399	Has flexible rubber hose, built-in swivel, and right-angle non-drip nozzle; non-drip tip	1,000 (69)	1/2"	70790
WATER, ANTI-FREEZE				
635129	Radiator bibb	300 (21)	1/4"	Non-drip tip

Digital, Metered Fluid Control Handles

Our metered control handle features a patented oval gear wheel design for precise and reliable measurement. Its digital LCD readout operates on two standard alkaline batteries.

- Lightweight
- Precise
- Fast reset
- Totalizes

Model	Max Flow Rate gpm (L)	Meter / Totalizing Increments	Max Working Pressure psi (bar)	Fluid Inlet NPT (F) in	Fluid Outlet
METERED, RIGID NOZZLE MODELS					
635390-11	4 (15)	Pints / gallons	1,000 (69)	1/2"	Non-drip tip
635390-22	4 (15)	Quarts / gallons	1,000 (69)	1/2"	Non-drip tip
635390-33	4 (15)	Liters / liters	1,000 (69)	1/2"	Non-drip tip
NON-METERED, RIGID NOZZLE MODELS (HANDLE AND NOZZLE ONLY)					
635391-11	4 (15)	-	1,000 (69)	1/2"	Non-drip tip
METERED, FLEXIBLE NOZZLE MODELS					
635390-1	4 (15)	Pints / gallons	1,000 (69)	1/2"	Non-drip tip
635390-2	4 (15)	Quarts / gallons	1,000 (69)	1/2"	Non-drip tip
635390-3	4 (15)	Liters / liters	1,000 (69)	1/2"	Non-drip tip
NON-METERED, FLEXIBLE NOZZLE MODELS (HANDLE AND NOZZLE ONLY)					
635391-1	4 (15)	-	1,000 (69)	1/2"	Non-drip tip
METER ONLY					
635190-1	4 (15)	Pints / gallons	1,000 (69)	1/2"	
635190-2	4 (15)	Quarts / gallons	1,000 (69)	1/2"	
635190-3	4 (15)	Liters / liters	1,000 (69)	1/2"	
METER, CONTROL HANDLES (WITHOUT NOZZLES)					
635390-10	4 (15)	Pints / gallons	1,000 (69)	1/2"	
635390-20	4 (15)	Quarts / gallons	1,000 (69)	1/2"	
635390-30	4 (15)	Liters / liters	1,000 (69)	1/2"	



635193



635399



635392

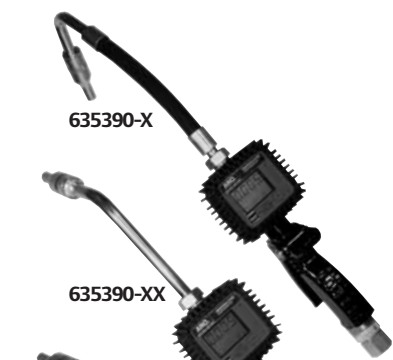

635390-X



635390-XX



635391-11



635391-1



635190-X
Order protective boot 74066 separately.

Metered Fluid Control Handles

Model	Units Of Measure	Totalizing Increments	Working Pressure	Inlet Size	Fluid Outlet
PRESET, DIGITAL METERED FLOW CONTROL					
Preset unit automatically shuts off when set quantity of fluid is delivered and meter indicator returns to zero. Totalizer registers up to 9,999 units.					
635360-2	Quarts	Gallons	1,000 (69)	1/2"	Non-drip flex extension
635360-22	Quarts	Gallons	1,000 (69)	1/2"	Non-drip rigid extension
635360-3	Liters	Liters	1,000 (69)	1/2"	Non-drip flex extension
635360-33	Liters	Liters	1,000 (69)	1/2"	Non-drip rigid extension
PRESET, METERED FLOW CONTROL					
Preset unit automatically shuts off when set quantity of fluid is delivered and meter indicator returns to zero. Totalizer registers up to 9,999 units.					
635364	1 to 60 quarts	Gallons	1,000 (69)	1/2"	9/16" diameter non-drip tip
635365	1 to 60 gallons	Gallons	1,000 (69)	1/2"	9/16" diameter non-drip tip
635367	1 to 60 liters with auto shut-off	Liters	1,000 (69)	1/2"	9/16" diameter non-drip tip



635360-2



635365

Non-drip Nozzle / Hose

Model	Description	Fluid Inlet NPT	Length in (mm)	Max Working Pressure psi (bar)
MOTOR OIL, GEAR OIL, TRANSMISSION FLUID				
629212	Non-drip nozzle / hose	3/4" (M)	12" (305)	900 (62)
629226	Non-drip nozzle / hose	1/2" (M)	11" (279)	900 (62)
629516	Non-drip nozzle / hose	1/2" (M)	13" (330)	1,000 (69)
629521	Right-angle nozzle / hose	1/2" (M)	15" (381)	1,000 (69)
6786	Right-angle, rigid, non-drip nozzle	1/4" (M)	6-1/2" (165)	1,000 (69)
60798	Rigid, non-drip nozzle	1/2" (M)	5-1/2" (133)	1,000 (69)
NOZZLE, FLEXIBLE HOSE, WITH NON-DRIP TIP				
629245-1	Flexhose, non-drip tip	1/2" (M)	15" (381)	1,000 (69)
NOZZLE, RIGID TUBE WITH NON-DRIP TIP				
629245-2	Rigid tube, non-drip tip	1/2" (M)	13" (330)	1,000 (69)



629226



629516



629521



6786

Control Handle Accessories

High-pressure Grease Control Handles

Model	Description	Max Working Pressure psi (bar)	Fluid Inlet NPT (F) in	Fluid Outlet in
GREASE CONTROL HANDLES				
636101	Dispenses lubrication at line pressure for lubricating grease fittings; does not include nozzle or hydraulic coupler; for applications requiring high-flow capacity; remove the 1/8" (M) x 3/8" (M) adapter for 3/8" (F) porting	7,500 (517)	3/8" (F)	11/16" – 16 (M) or 1/8 NPT (F)
636111	Dispenses lubricant at line pressure for lubricating grease fittings; includes inlet material filter and curved nozzle with hydraulic coupler; remove the 1/8" (M) x 3/8" (M) adapter for 3/8" (F) porting	7,500 (517)	1/8" (M) or 3/8" (F)	Hydraulic coupler
636103	High-pressure booster handle delivers line pressure for normal lubrication; trigger booster feature delivers 10,000 psi (689 bar) to loosen tougher fittings; includes curved nozzle with hydraulic coupler, inlet material filter and manual pressure vent for easy disconnection; do not use with whip hose	7,500 (517)	1/8" (M) or 3/8" (F)	Hydraulic coupler
WHIP HOSES FOR GREASE CONTROL HANDLES*				
629742	Extra-long, wire braid (624201-02) whip hose with hydraulic coupler and swivel; overall length of 29-1/2" (749 mm); for use with coupler 636111 high-pressure control handle; allows operator to access hard-to-reach fittings	5,000 (345)	1/8" (F)	636046 hydraulic

*WARNING: Not for use with 636103 high-pressure booster handle.

Model	Description
WATER, ANTI-FREEZE, WINDSHIELD FLUID	
635129	Fluid dispensing nozzle — 635129 bibb with trigger 1/4" NPT(F) inlet, zinc die casting with brass, and nitrile seals for water or oil service; radiator-type bibb has 1/4" fluid inlet and non-drip tip

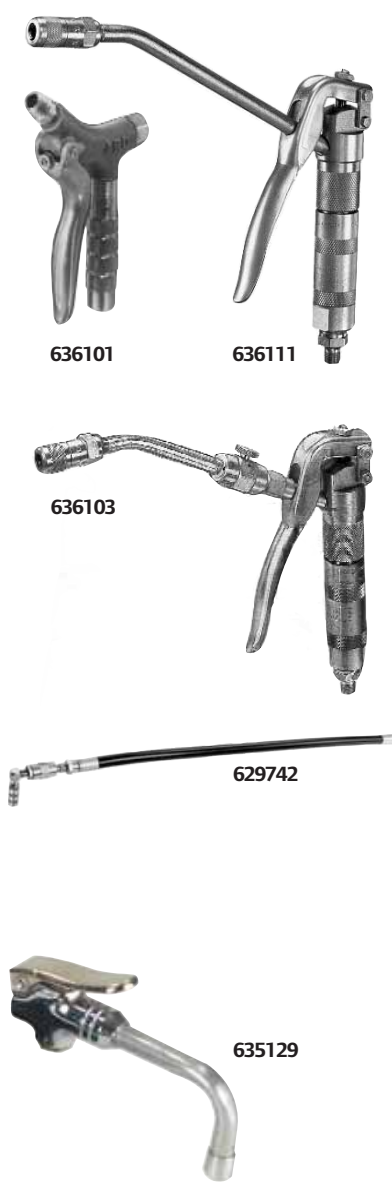

Hand-operated Pumps

Grease NLGI 0 – 3 lb

Model	Description
LUBRICATION PUMPS, 35-LB, DRUM COVER TYPE	
611016	Ball joint lubricator — Can deliver up to 1/4 oz of lubricant per stroke; includes 72006 drum cover, 622511-10 hose assembly, 640095-3-B follower plate, and 72806 booster control handle; control handle capable of generating up to 7,500 psi



Motor Oil, Gear Oil, Transmission Fluid

Model	Description
MOTOR OIL, GEAR OIL, TRANSMISSION FLUID	
5-GAL	
611170	Capable of high-volume delivery; includes 621597-5 hose / dispensing, 2:1, 4:1, 7:1 nozzle assembly with 5', 1/2" ID hose and 72006 drum cover



Hand-held Grease Guns

550 Heavy-duty Grease Gun

This heavy-duty grease gun has a comfort grip handle and can develop up to 10,000 psi. Features include an easy-to-load locking plunger, an ergonomic T-handle, and a filler nipple and air vent. The 550 comes standard with a 6" angle extension and an 18" whip hose, both with a four-jaw coupler.



570 Heavy-duty Grease Gun

This heavy-duty grease gun has a comfort grip handle and can develop up to 7,500 psi. Features include an easy-to-load locking plunger, an ergonomic T-handle, and a filler nipple and air vent. The 570 comes standard with a 3.5" straight extension and an 18" whip hose, both with a four-jaw coupler.

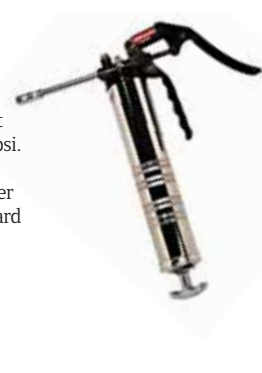

590 Heavy-duty Grease Gun

This heavy-duty grease gun has a 40:1 pressure ratio, an easy-to-load locking plunger, an ergonomic T-handle, and a filler nipple and air vent. The 590 comes standard with a 6" angle extension with a four-jaw coupler.



5190 Ultra-duty Grease Gun

A new, ergonomic design, the 5190 grease gun has a handle that can be swiveled 180° from the cartridge. The larger handle improves comfort while still packing a 40:1 pressure ratio.

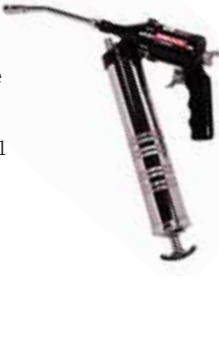

Model	Performance Rating	Max Input Pressure psi	Max Output Pressure psi	Grease Coupler	Included
HAND-HELD GREASE GUNS					
550	Heavy-duty	Hand lever	10,000	4-jaw coupler	6" extension and 18" whip hose
570	Heavy-duty	Hand lever	7,500	4-jaw coupler	3.5" extension and 18" whip hose
590	Heavy-duty	150	6,000	4-jaw coupler	6" extension
5190	Ultra-duty	150	6,000	4-jaw coupler	6" extension

Fittings and Accessories

Grease Gun Accessories

Button head coupler

636020

Standard button coupler. Can be converted to either push-on or pull-on.

636024

Standard button coupler. Can be converted to either push-on or pull-on.



636024

Standard Hydraulic Couplers

636027

Small diameter hydraulic coupler.

636028

Reversible jaw hydraulic coupler.

636046

Small diameter hydraulic coupler with ball check.



636028



636046

Model	Inlet Thread Connection in	Length in (mm)	Max Working Pressure psi (bar)
636020	7/ 16" - 27 (F)	-	8,000 (552)
636024	1/8" NPT (F)	-	8,000 (552)

Model	Inlet Thread Connection in	Length in (mm)	Max Working Pressure psi (bar)
636027	1/8" NPT (F)	1-5/8" (41)	6,000 (414)
636028	1/8" NPT (F)	1-5/8" (41)	10,000 (689)
636046	1/8" NPT (F)	1-7/16" (37)	6,000 (414)

Swivels

Model	Description	Size NPT in
636077	Z Swivel	1/8" (M) x 1/8" (F)
636086- B	Z Swivel	1/4" (M) x 1/4" (F)
636087- B	Z Swivel	1/4" (M) x 1/4" (F) with filter element
635106	Z Swivel	1/2" (F) x 3/8" (M)
636075	Straight Swivel	1/8" (M) x 1/8" (F)
636085	Straight Swivel	3/8" (M) x 3/8" (F)
635117	Straight Swivel	1/2" (M) x 1/2" (F)
635108	Straight Swivel	3/4" (M) x 3/4" (F)
635107	Straight Swivel	3/8" (M) x 1/2" (F)
676	Male Adapter	1/8" (M) x 1/8" (M)



636077



636075



635108



676

Grease Fitting Accessories

Model	Description	Thread Size NPT in	Height in
STRAIGHT			
6000	Straight	1/8" (M)	21/32"
6001	Straight	1/8" (M)	1-1/4"
6026	Straight	1/4" (M)	7/8"
6009	Short straight	1/4" - 28	17/32"
6010	Long straight	1/4" - 28	11/16"
ELBOW			
6004	30° elbow	1/8" (M)	29/32"
6005	45° elbow	1/8" (M)	7/8"
6011	45° elbow (short)	1/4" - 28	13/16"
6006	65° elbow	1/8" (M)	7/8"
6028	67-1/2° elbow	1/4" (M)	1-5/32"
6013	90° elbow (short)	1/4" - 28	3/4"
DRIVE TYPE FITTINGS			
6060	Straight	5/16" serrated	5/8"
6056	Straight	1/4" serrated	37/64"
6069	Straight	3/16" serrated	19/32"
6070	Straight (less spring and ball)	3/16" serrated	37/64"
ELBOW BODIES			
6045	90° elbow	1/8" (M) x 1/8" (F)	1
BUTTON-HEAD FITTINGS			
2087*	Standard	1/8" (M)	13/16"
6041	Giant	1/2" (M)	1-3/32"

*POA status pricing required.

Model	Description
GREASE FITTING EASY-OUT TOOLS	
636053	Four function tool • Easy-out for removing broken fittings • 1/8" NPT tap • 3/8" socket for removing hydraulic fittings • 7/16" socket for removing hydraulic fittings
636054	Four function tool • Easy-out for removing broken fittings • 1/4"-28 tap • 5/16" socket for removing hydraulic fittings • 3/8" socket for removing hydraulic fittings



Grease Fitting Assortment - 640049

Quantity	Model	Description
100-piece selection of the most common grease fittings packaged in a five-compartment plastic container.		
20	6000	1/8" NPT (M) straight
50	6009	1/4"-28 (M) short straight
10	6004	1/8" NPT (M) 30° elbow
10	6006	1/8" NPT (M) 65° elbow
10	6013	1/4"-28 (M) 90° elbow

General Installation Accessories

Overrun Controls, Pressure Relief Valve

Model	Air Inlet NPT(F) in	Air Outlet NPT(F) in	Pressure Range psi	For Use With
ARO-STOP® VALVES				
ARO-STOP valves shut off air to pump when material container is empty or fluid line is broken. Both have quick-set and reset features.				
635040	1/4"	1/4"	20 - 175	Thunder Series and (1.4 - 12) 200 Series and 1/2" diaphragm pump (includes connecting hose)
(max flow rate of 23 scfm @ 90 psi)				
23644-400	1/2"	1/2" NPT (M)	20 - 175	425 Series and 600 Series only (1.4 - 12) and 1" diaphragm pump



635040



23644-400

Protect your investment



Pump run away happens when a material container is depleted and the pump cycles fast and needlessly. It's not good. So, protect your pump investment with an ARO-STOP® valve.

Model	Air Inlet NPT (F) in	Air Outlet NPT (F) in	Pressure Range psi (bar)	For Use With
LOW-LEVEL CUTOFF				
Low-level cutoff prevents the entry of air into the fluid line by closing the pump intake when material supply is exhausted. Threads to bottom of siphon tube for immersion in fluid. Also serves as a check valve.				
640153	-	-	-	200 Series and 425 Series pumps with 1-1/2" NPT (F) threads (not for pumps that exceed 6 GPM), Thunder Series 3" air motor pumps



640153

Pressure Relief Valve / Valve Kit

Model	Description
PRESSURE RELIEF VALVE / VALVE KITS	
61117	Pressure relief valve is used on material outlet side of pump to automatically allow bleed-back of material to container in applications where thermal expansion is present.
61118	Pressure relief valve kit includes 61117 relief valve, reducing bushing, compression coupling, 3' of plastic drain tubing, and grommet (for drum attachment)

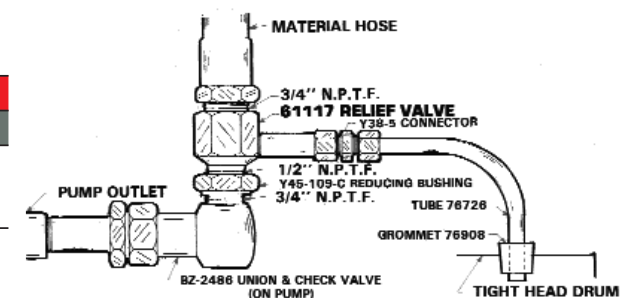

General Accessories

640058-2

Dolly for 16-gal keg.

94421

Drum cover for 16-gal keg.

640165

Follower plate for 3" Thunder Series and 120-lb container. For use with Thunder Series grease.



640015-1



640095-2-B

640015-1

Follower plate for 3" Thunder Series and 400-lb container. For use with Thunder Series grease.

640095-1-B

Follower plate for 2" Thunder Series and 35-lb container. For use with Thunder Series grease.

640095-2-B

Follower plate for 3" Thunder Series and 35-lb container. For use with Thunder Series grease.

67145-1

Bung adapter for 2" Thunder Series grease pump. For use with Thunder Series grease.



67145-X

67145-2

Bung adapter for 3" Thunder Series grease pump. For use with Thunder Series grease.



67145-X-B

67145-3-B

Bung adapter for 2" Thunder Series oil pump. For use with Thunder Series oil.

67145-4-B

Bung adapter for 3" Thunder Series oil pump. For use with Thunder Series oil.

640153

Low level cutoff for 3" Thunder Series oil pump. For use with Thunder Series oil.

61118

Pressure relief valve kit.

95183

Oil tapper 3/4" NPT inlet.

77617

Oil tapper fitting (converts oil tapper to 1/2" inlet).

640164

Tie-down kit for 16-gal / 120-lb containers.

71027-1

Tie-down kit for 55-gal / 400-lb containers.

Dispensing Accessories

621516-10

10' hose and dispensing bibb for diaphragm pump. For use with diaphragm pump.



621516-10

635129

Dispensing bibb for use with diaphragm pump.

621523-10

10' hose with no-drip nozzle. For use with diaphragm pump.



621523-10

95189

Poly cam coupler 1/2" NPT (M)

95190

Aluminum cam coupler 1/2"NPT (M)

Installation Accessories

65986-1

Siphon tube with 6' hose for 55-gal drum with 2" bung. For use with Thunder Series and diaphragm pumps.

61601

Siphon tube with 6' hose for 55-gal drum for wall-mounted pump. For use with Thunder Series pump.



61601

66779

Siphon tube for 55-gal drum. For use with Thunder Series and diaphragm pumps.

66779-1

Siphon tube for 55-gal drum. For use with Thunder Series and diaphragm pumps.

Need Copy

66779-2

Siphon tube with 6' hose for 275 Series container. For use with Thunder Series and diaphragm pumps.

622701-6

6' siphon hose. For use with Thunder Series and diaphragm pumps.

61113

Wall-mount for stub pumps. For use with Thunder Series pump.

61412

Siphon tube for 1/2" diaphragm pump.

76763

Wall-mount for 1/2" diaphragm pumps.

66100

Wall-mount for 1" diaphragm pumps.

High-pressure Hose

Model	ID in	OD in	Fitting Threads Both Ends	Max Pressure psi (bar)	Length ft (m)
BUNA-N TUBE, NEOPRENE COVER					
1-WIRE BRAID					
623501-2	1/2"	29/32"	1/2" NPT (M)	2,000 (138)	2 (0.6)
623501-5	1/2"	29/32"	1/2" NPT (M)	2,000 (138)	5 (1.5)
623501-6	1/2"	29/32"	1/2" NPT (M)	2,000 (138)	6 (1.8)
623501-8	1/2"	29/32"	1/2" NPT (M)	2,000 (138)	8 (2.4)
2-WIRE BRAID					
624201-2	1/4"	11/16"	1/8" NPT (F)	5,000 (345)	2 (0.6)
624201-6	1/4"	11/16"	1/8" NPT (F)	5,000 (345)	6 (1.8)
624201-10	1/4"	11/16"	1/8" NPT (F)	5,000 (345)	10 (3)
624201-30	1/4"	11/16"	1/8" NPT (F)	5,000 (345)	30 (9.1)
624401-4	3/8"	27/32"	3/8" NPT (M)	4,000 (276)	4 (1.2)
624401-8	3/8"	27/32"	3/8" NPT (M)	4,000 (276)	8 (2.4)
624601-4	3/4"	1-1/4"	3/4" NPT (M)	2,250 (155)	4 (1.2)
ELASTOMER TUBE, POLYESTER COVER					
1-WIRE BRAID					
628067-3	1"	1-1/4"	1" NPT (M)	800 (55)	3 (0.9)

Low-pressure Hose

Model	ID in	OD in	Fitting Threads Both Ends	Max Pressure psi (bar)	Length ft (m)
NEOPRENE TUBE, NEOPRENE COVER					
2-FABRIC BRAID					
622651-5	3/4"	1-3/16"	3/4" NPT (M)	600 (41)	5 (1.5)
622651-6	3/4"	1-3/16"	3/4" NPT (M)	600 (41)	6 (1.8)
622651-10	3/4"	1-3/16"	3/4" NPT (M)	600 (41)	10 (3)
622651-15	3/4"	1-3/16"	3/4" NPT (M)	600 (41)	15 (4.6)
BUNA-N TUBE, NEOPRENE COVER					
2-FABRIC BRAID					
622201-3	1/4"	5/8"	1/4" NPT (M)	250 (17)	3 (0.9)
622201-5	1/4"	5/8"	1/4" NPT (M)	250 (17)	5 (1.5)
622201-25	1/4"	5/8"	1/4" NPT (M)	250 (17)	25 (7.6)

In selecting a hose, be sure the hose material is compatible with the fluid being pumped and that the maximum working pressure will not be exceeded in the application. Only those hose length options listed with each model are available. Substitute -XX with -5, -15, -25, etc., to indicate length selection. (Example: Substitute -XX with length selection, such as -50. If length is single digit, use that digit only. Do not add zeros.)

***CAUTION: These hoses cannot be used with 100:1 ratio pumps.**

Never use a hose with a maximum pressure rating lower than the highest pressure the pump can generate.

Fluid Control Valves

Model	Inlet Outlet NPT in	Body Material	Seat Material	Max Working Pressure psi (bar)
BALL VALVES				
Used to control the on-off flow of fluid material or air. Select proper working pressure and material compatibility for application.				
61124	3/4" (F)	Bronze	Buna-N	200 (14)
66592	1/2" (F)	Carbon steel	Teflon	2,000 (138)
66593	3/8" NPS (M) x 3/8" (M)	303 stainless steel	Teflon	4,000 (276)
PLUG VALVES				
Y28-1	1/4" (F)	Brass	N/A	150 (10)
Y28-2	1/8" (F)	Brass	N/A	150 (10)
NEEDLE VALVES				
636042	1/2" (F)	Carbon steel	Leather	8,000 (552)
636043	1/2" (M) x 1/2" (F)	Carbon steel	Leather	8,000 (552)
92818	1/4" (F) x 1/4" (M)	Brass	Leather	125 (9)
GLOBE VALVES				
Y26-1	3/4" (F)	Brass	Graphite	125 (9)
BALL VALVES				
104077-2	1/4" (F)	Nickel-plated brass	Teflon	225 (16)
104077-3	3/8" (F)	Nickel-plated brass	Teflon	225 (16)
104077-4	1/2" (F)	Nickel-plated brass	Teflon	225 (16)



66592



Y28-1

Fittings

Model	Thread Size NPT in	Material of Construction
STRAIGHT COUPLINGS — 150 PSI (10 BAR) MAX		
6,750 PSI (446 BAR) MAX		
77617	3/8" (M) x 1/2" (M)	Zinc-plated steel
5,000 PSI (345 BAR) MAX		
76751	1/4" (M) x 11/16-16" (M)	Steel
8,000 PSI (552 BAR) MAX		
2722	1/8" (M) x 11/16-16" (M)	Steel
73581	1/4" (M) x 3/8" (M)	Steel
76493	1/8" (M) x 3/8" (M)	Steel
REDUCING BUSHINGS — 150 PSI (10 BAR) MAX		
Y45-5-C	1/4" (F) x 1/2" (M)	Iron
Y45-9-C	1/2" (F) x 3/4" (M)	Iron
3,000 PSI (207 BAR) MAX		
Y45-102-C	1/8" (F) x 3/8" (M)	Steel
Y45-105-C	1/4" (F) x 1/2" (M)	Steel
Y45-106-C	3/8" (F) x 1/2" (M)	Steel
Y45-109-C	1/2" (F) x 3/4" (M)	Steel
10,000 PSI (690 BAR) MAX		
6788	1/4" (F) x 1/2" (M)	Steel
STREET ELBOWS — 150 PSI (10 BAR) MAX		
Y43-1-C	1/8" (M) x 1/8" (F)	Iron
Y43-2-C	1/4" (M) x 1/4" (F)	Iron
Y43-4-C	1/2" (M) x 1/2" (F)	Iron
Y43-5-C	3/4" (M) x 3/4" (F)	Iron
Y43-6-C	1" (M) x 1" (F) plated	Iron



77617



Y45-106-C



Y43-2-C

Model	Thread Size NPT in	Material of Construction	Max Pressure psi (bar)
STRAIGHT COUPLINGS — 150 PSI (10 BAR) MAX			
Y43-44	1/2" (F) x 1/2" (F)	Iron	
Y43-48-C	1-1/2" (F) x 1-1/2" (F)	Iron	
REDUCING COUPLINGS — 8,000 PSI (552 BAR) MAX			
4280	1/8" (F) x 3/8" (F)	Steel	
SHORT NIPPLES — 150 PSI (10 BAR) MAX			
Y27-2-C	1/4" (M) x 1/4" (M)	Plated iron	
Y27-52-C	1/4" (M) x 1/4" (M)	Plated iron	
Y27-54-C	1/2" (M) x 1/2" (M)	Plated iron	
Y27-55-C	3/4" (M) x 3/4" (M)	Plated iron	
Y27-56-C	1" (M) x 1" (M)	Plated iron	
Y27-58-C	1-1/2" (M) x 1-1/2" (M)	Plated iron	
8,000 PSI (552 BAR) MAX			
676	1/8" (M) x 1/8" (M)	Steel	
1950	1/4" (M) x 1/4" (M)	Steel	
70749	1/2" (M) x 1/2" (M)	Steel	
LONG NIPPLES — 150 PSI (10 BAR) MAX			
LENGTH — 2" (51 MM)			
Y44-11-C	1/4"	Plated iron	
LENGTH — 2-1/2" (63.5 MM)			
Y44-12-C	1/4"	Plated iron	
ELBOWS — 150 PSI (10 BAR) MAX			
Y43-12-C	1/4" (F) x 1/4" (F)	Iron	
Y43-15-C	3/4" (F) x 3/4" (F)	Iron	
3,000 PSI (207 BAR) MAX			
Y43-214-N	1/2" (F) x 1/2" (F)	Steel	
Y43-215	3/4" (F) x 3/4" (F)	Steel	



Y43-44



4280



676



Y43-214-N

Fittings

Model	Thread Size NPT in	Material of Construction	Max Pressure psi (bar)
SWIVEL UNIONS			
75364	1/4" (M) x 1/4" (F)	Steel	10,000 (690)
75365	3/8" (M) x 3/8" (F)	Steel	9,000 (621)
75366	1/2" (M) x 1/2" (F)	Steel	6,750 (466)
75367	3/4" (M) x 3/4" (F)	Steel	4,375 (302)
75368	1" (M) x 1" (F)	Steel	3,550 (245)
75369	1/4" (F) x 1/4" (F)	Steel	10,000 (690)
75370	3/8" (F) x 3/8" (F)	Steel	9,000 (621)
PLAIN TEE — FEMALE			
Y43-32-C	1/4" x 1/4" x 1/4"	Iron	150 (10)
Y43-233-C	3/8" x 3/8" x 3/8"	Steel	3,000 (207)
PIPE PLUGS — MALE			
Y17-50	1/8" countersunk (hex)	Steel	10,000 (690)
Y17-51	1/4" countersunk (hex)	Steel	10,000 (690)
FEMALE ADAPTER			
4280	3/8" (F) x 1/8" NPT (F)	Steel	8,000 (552)
ADAPTER UNIONS			
Y167-3	1/2" (F) x 3/8" NPT (M)	Steel	6,000 (414)
Y167-4	3/4" (F) x 1/2" NPT (M)	Steel	5,000 (345)
Y167-5	1/2" (F) x 1/4" NPT (M)	Steel	6,000 (414)
4295	1/8" PTF SAE short (F) x 7/16-27" (M)	Steel	8,000 (552)
4616	1/2" (F) x 1-3/8"-18 (M)	Steel	8,000 (552)
6847	3/8" (F) x 0.523"-27 (M)	Steel	8,000 (552)



65845
Used to prevent back flow of material.

Fluid Couplers

Model	Description
92021	Quick connect fluid coupler (female) — 3/4" NPT (F) couples with 92022 fluid connector
92022	Quick connect fluid connector (male) — 3/4" NPT (F) couples with 92021 fluid coupler

WARNING: To ensure safe operation, be sure the maximum working pressure of your fluid handling system does not exceed the maximum working pressure of the fittings.

Fluid Ball Check Unions

Model	Body Material	Ball Material	Seat Material	Inlet NPT in	Outlet NPT in	Max Working Pressure psi (bar)
65845	Carbon steel	440C Stainless steel	440 F Stainless steel	3/4" (M)	3/4" (M)	8,000 (552)
66559	Carbon steel	440C Stainless steel	440 F Stainless steel	1" (M)	1" (F)	8,000 (552)

Filters, Regulators, and Lubricators

Filters, Regulators, Lubricators

Your Ingersoll Rand air tools will last longer and have fewer problems and repair costs when you use the high-quality filters, regulators, and lubricators specially made to match your tool.

Filters

Ingersoll Rand compressed air filters are designed to remove airborne solid and liquid contaminants that can plug small orifices and affect performance, or cause excessive wear and premature equipment failure. Several types of filters are offered, including models with coalescing elements for removal of oil aerosols and particles down to 0.3 micron.



Regulators

Ingersoll Rand air line regulators provide controlled, consistent air pressure as required for specific air equipment connected to the air system. They are designed to deliver the pressure you need, with precise control over outlet pressure. They help maintain relative torque and speed control, and also conserve compressed air.



Lubricators

Ingersoll Rand fog-type lubricators help ensure that air equipment receives the required lubrication to maintain optimum performance, reduce wear, and extend life. They are designed to provide the correct amount of oil, with a constant ratio to CFM. Precise oil feed adjustment allows the proper oil delivery rate. Lubricators should be installed close to the downstream application to ensure effective distribution oil to the equipment.



Point-of-purchase display packaging

Some of our filters, regulators, and lubricators up to 1/2" NPT are packaged in clamshell-style packaging for easy, flexible display options and effective, self-selling graphics and copy.



Combination Units with Gauge

Size NPT (F) in	Filter-Regulator-Lubricator	Packaging Type
1/4" mini	C121-820	Clamshell
1/4"	C221-810	Clamshell
3/8"	C231-810	Clamshell
1/2"	C241-810	Clamshell
3/4"	C28453-810	
1"	C28463-810	
1-1/4"	C28473-810	
1-1/2"	C28483-810	



Individual Units

Specifications	Filter	Regulator	Lubricator
1/8" NPT (F) MINI			
Catalog Number	F111-420	R111-600	L111-120
Flow Rate — scfm	345	13	190
Adjustable Pressure Range — psig	N/A	5 – 125	N/A
Bowl Size — oz	1.1	N/A	1.1
Bowl Type	Composite nylon	N/A	Composite nylon
Weight — lb	1.48	1.38	1.5
Packaging Type	Clamshell	Clamshell	Clamshell
1/4" NPT (F) MINI			
Catalog Number	F121-420	R121-600	L121-120
Flow Rate — scfm	38	13	41
Adjustable Pressure Range — psig	N/A	5 – 125	N/A
Bowl Size — oz	1.1	N/A	1.1
Bowl Type	Composite nylon	N/A	Composite nylon
Weight — lb	1.46	1.34	1.5
Packaging Type	Clamshell	Clamshell	Clamshell
1/4" NPT (F)			
Catalog Number	F221-410	R221-600	L221-110
Flow Rate — scfm	54	100	75
Adjustable Pressure Range — psig	N/A	5 – 125	N/A
Bowl Size — oz	6	N/A	6
Bowl Type	Metal	N/A	Metal
Weight — lb	1.48	1.38	1.5
Packaging Type	Clamshell	Clamshell	Clamshell
3/8" NPT (F)			
Catalog Number	F231-410	R231-600	L231-110
Flow Rate — scfm	100	130	100
Adjustable Pressure Range — psig	N/A	5 – 125	N/A
Bowl Size — oz	6	N/A	6
Bowl Type	Metal	N/A	Metal
Weight — lb	1.46	1.34	1.44
Packaging Type	Clamshell	Clamshell	Clamshell
1/2" NPT (F)			
Catalog Number	F241-410	R241-600	L241-110
Flow Rate — scfm	122	150	110
Adjustable Pressure Range — psig	N/A	5 – 125	N/A
Bowl Capacity — oz	6	N/A	6
Bowl Type	Metal	N/A	Metal
Weight — lb	1.43	1.3	1.36
Packaging Type	Clamshell	Clamshell	Clamshell

Specifications	Filter	Regulator	Lubricator
3/4" NPT (F)			
Catalog Number	F25451-110	R27451-100	L26451-110
Flow Rate — scfm	345	125	190
Adjustable Pressure Range — psig	N/A	5 – 125	N/A
Bowl Capacity — oz	2.87	N/A	6.11
Height — in	8.4"	5.9"	9.36"
Width — in	2.9"	2.9"	2.39"

Specifications	Filter	Regulator	Lubricator
1" NPT (F) (METAL BOWLS)			
Catalog Number	F25461-110	R27461-100	L26461-110
Flow Rate — scfm	345	200	200
Adjustable Pressure Range — psig	N/A	10 – 125	N/A
Bowl Capacity — oz	8	N/A	19
Height — in	11.46"	7.83"	10.67"
Width — in	3.94"	3.94"	3.94"

Combination Over/Under Filters-Regulators

Specifications	1/8" NPT (F) Mini	1/4" NPT (F) Mini
Catalog Number	P114-620	P124-620
Flow Rate — scfm	13	13
Adjustable Pressure Range — psig	5 – 125	5 – 125
Bowl Size — oz	—	—
Bowl Type	Composite	Composite
Weight — lb	2.05	2.03
Packaging Type	Clamshell	Clamshell

Specifications	1/4" NPT (F)	3/8" NPT (F)	1/2" NPT (F)
Catalog Number	P224-610	P234-610	P244-610
Flow Rate — scfm	93	135	140
Adjustable Pressure Range — psig	5 – 125	5 – 125	5 – 125
Bowl Capacity — oz	6	6	6
Bowl Type	Metal	Metal	Metal
Weight — lb	2.05	2.03	2.00
Packaging Type	Clamshell	Clamshell	Clamshell

In-line Series Filters-Regulators

Specifications	Filter	Lubricator
1/4" NPT (F)		
Catalog Number	F25451-110	L26451-110
Flow Rate — scfm	168	200
Adjustable Pressure Range — psig	N/A	N/A
Bowl Capacity — oz	2.87	6.11
Height — in	8.4"	9.36"
Width — in	2.9"	2.39"
Catalog Number	N/A	L01-03-000
Flow Rate — scfm	N/A	22
Bowl Capacity — oz	N/A	0.25
Height — in	N/A	3"
Width — in	N/A	1-1/8" hex



Air Line Filter, Regulators, and Lubricators

Model	Inlet NPT (F)	Bowl	Filter Sump Capacity oz (mL)	Filter Element microns	Flow scfm	Max Inlet Pressure psi (bar)
MODULE / AIR 1000						
FILTER						
F25121-200	1/4"	Polycarbonate	0.6 (18)	20	12	200 (14)
REGULATOR (29850 GAUGE NOT INCLUDED. SEE PG. 34) PRESSURE RANGE OF REGULATOR: 5-125 PSI						
R27121-100	1/4"	N/A	N/A	N/A	13	250 (17)
LUBRICATOR						
L26121-100	1/4"	Polycarbonate	1.1 (33)	N/A	60	200 (14)
PIGGY-BACK FILTER-REGULATOR (GAUGE NOT INCLUDED. SEE PG. 34)						
P29122-100	1/4"	Polycarbonate with auto drain	1.1 (33)	20	12	200 (14)
FILTER-REGULATOR-LUBRICATOR (INCLUDES GAUGE)						
C28121-800	1/4"	Polycarbonate	1.1 (33)	20	13	200 (14)
MODULE / AIR 2000 (ALL BOWLS INCLUDE SIGHT GAUGES)						
FILTER						
F25221-110	1/4"	Metal	6 (177)	40	54	175 (12)
F25241-110	1/2"	Metal	6 (177)	40	122	175 (12)
F25231-110	3/8"	Metal	6 (177)	40	100	175 (12)
REGULATOR (INCLUDES GAUGE) PRESSURE RANGE OF REGULATOR: 5-125 PSI						
R27221-600	1/4"	N/A	N/A	N/A	100	200 (14)
R27241-600	1/2"	N/A	N/A	N/A	150	200 (14)
R27231-600	3/8"	N/A	N/A	N/A	130	—
LUBRICATOR						
L26221-110	1/4"	Metal	6 (177)	N/A	75	175 (12)
L26241-110	1/2"	Metal	6 (177)	N/A	110	175 (12)
PIGGY-BACK FILTER-REGULATOR (INCLUDES GAUGE) REGULATOR RANGE: 5-125 PSI						
P29221-610	1/4"	Metal	6 (177)	40	93	200 (14)
P29241-610	1/2"	Metal	6 (177)	40	140	200 (14)
FILTER-REGULATOR-LUBRICATOR (INCLUDES GAUGE AND MOUNTING BRACKET) REGULATOR RANGE: 5-125 PSI						
C28221-810	1/4"	Metal	6 (177)	40	N/A	175 (12)
C28231-810	3/8"	Metal	6 (177)	40	N/A	175 (12)
C28241-810	1/2"	Metal	6 (177)	40	N/A	175 (12)

A whole new way to run an air line

Ingersoll Rand / ARO Module / Air

- Each unit has threaded ports and can be used with standard pipe nipples
- Totally modular design permits removal of unit from line without disturbing hard piping, also speeds up regular or unscheduled maintenance
- Modular spacers have retained O-rings and fasteners to prevent loss during routine maintenance
- Push-pull regulator knob allows easy, one-hand adjustment
- Safety lock-out valve provides protection from unexpected start-ups
- Modular end pipe adapters fit 1/4", 3/8", 1/2", and 3/4" pipe sizes.
- High-tech modern appearance enhances any service area; black powdercoat finish provides long-lasting protection against weather and hard use



Limited selection shown — for more information on the entire line of Ingersoll Rand / ARO filters, regulators, and lubricators, please refer to form 9340-R.

Air Line Filter, Regulators, and Lubricators

Model	Inlet NPT (F) in	Bowl	Capacity oz (mL)	Filter Element microns	Flow scfm	Max Inlet Pressure psi (bar)
HEAVY-DUTY FILTER						
25341-020	1/2"	Polycarbonate with guard	10 (295)	40	82	200 (14)
25351-020	3/4"	Polycarbonate with guard	10 (295)	40	87	200 (14)
25361-020	1"	Polycarbonate with guard	10 (295)	40	88	200 (14)
REGULATOR (100067 GAUGE NOT INCLUDED. SEE BELOW)						
PRESSURE RANGE OF REGULATOR: 0 – 125 PSI						
27344-000	1/2"	N/A	N/A	N/A	256	250 (17)
27354-000	3/4"	N/A	N/A	N/A	287	250 (17)
27364-000	1"	N/A	N/A	N/A	293	250 (17)
LUBRICATOR						
26341-020	1/2"	Polycarbonate with guard	10 (295)	40	65	200 (14)
26351-020	3/4"	Polycarbonate with guard	10 (295)	40	75	200 (14)
26361-020	1"	Polycarbonate with guard	10 (295)	40	75	200 (14)
FILTER-REGULATOR-LUBRICATOR (INCLUDES GAUGE)						
PRESSURE RANGE OF REGULATOR: 5 – 125 PSI						
28343	1/2"	Polycarbonate with guard	10 (295)	40	65	200 (14)
28353	3/4"	Polycarbonate with guard	10 (295)	40	75	200 (14)
28363	1"	Polycarbonate with guard	10 (295)	40	75	200 (14)

Air Regulator Gauges

Model	Description	Lens Material	Pressure Range psi (bar)	Thread NPT in	For Use With
GAUGES					
29850	Regulator gauge	Polycarbonate	0 – 160 (0 – 11)	1/8"	Module Air 1000
100067	Regulator gauge	Polycarbonate	0 – 160 (0 – 11)	1/4"	Module Air 2000 and Heavy-duty

Mounting Hardware

Model	Description	For Use With
BRACKET AND PANEL NUTS		
29077	Wall-mounting bracket	Heavy-duty
29623	Wall-mounting bracket	Module Air 2000
104173	Panel nut	Module Air 2000
29668	Wall-mounting bracket	Module Air 1000
104094	Panel nut	Module Air 1000



Limited selection shown — for more information on the entire line of Ingersoll Rand / ARO filters, regulators, and lubricators, please refer to form 9340-R.

Self-evacuating Waste Oil Caddies

Self-evacuating Waste Oil Caddy

The fast and affordable way to transfer used oil to any bulk storage tank using compressed air. Ingersoll Rand self-evacuating waste oil caddies eliminate the need for waste oil pumps. Pressurized draining reduces downtime and increases productivity.

Features and benefits

- Compatible with most existing shop air systems, unlike many other caddies that require restricted psi
- Offers increased mobility with casters on all corners, two locking
- Increases productivity levels — less time waiting for draining and more time in the bay
- Comes standard with regulator, gauge, and either a 6' hose with nozzle or a 3/4" cam coupler
- Minimizes spills with an automatic ball check valve in the downtube



Waste Oil and Fresh Oil Caddy Systems

Fresh Oil Caddy

Built tough to fit the way you work

The 24-gal Ingersoll Rand fresh oil caddy system provides a cost-effective solution for dispensing synthetic oil. These caddies are easy to use and require minimal maintenance. The fresh oil caddy system eliminates the need to add costly bulk storage tanks for oils and fluids. Specialized fluids, such as 5W-20 synthetic motor oils, can now be stored in the fresh oil caddy system and wheeled to the vehicle to be dispensed.

Features and benefits

- Increases productivity by increasing mobility
- Uses a 3:1 piston pump with air filter-regulator and gauge
- Dispenses fluids through a 6' long 1/2" diameter hose
- Includes a digital dispensing meter (totalizing)
- Improves mobility around the shop with 6" front casters

612999-24

Our fresh oil caddy provides a cost-effective portable option to expensive oil systems. The fresh oil caddy provides a great way to reduce costs and increase productivity. The system is ideal for specialized fluids such as 5W-20 synthetic motor oils.



Model	Capacity gal (L)	Air Inlet in (mm)	Fluid Outlet in (mm)	Max. Working Flow Rate gpm (L/min)	Free Flow Rate Gal. / Min. gal (L/min)	Operating Air Pressure psi (bar)
FRESH OIL CADDY						
612999-24	24 (91)	1/2" (13)	1/2" (13)	6 (23)	9 (34)	40 – 100 (3 – 7)

Waste Oil Caddies

62131

This self-evacuating oil drain can be connected to shop air up to a recommended 70 psi, unlike most drains that are restricted to 10 – 20 psi. At 60 psi, the oil drain can be evacuated in under two minutes. The 62131 comes with casters on all corners (two locking), regulator, gauge, 5' output hose, and utilizes an automatic check ball in the down tube.



67384

The 67384, similar to 62131, allows shop air to be connected to the drain for fast and reliable operation. The model includes an automatic check ball, padded handle, and 3/4" high flow cam coupler outlet. The 67384 contains a larger funnel.



Model	Max Inlet Pressure psi (bar)	Tank Capacity gal (L)	Height Range m	Fluid Outlet	Air Inlet in (mm)	Funnel Size in (mm)
WASTE OIL CADDIES						
62131	150 (10)	21 (80)	49 – 70 (1.3 – 1.8)	6' hose with nozzle	1/4" (6)	16" (406)
67384	150 (10)	21 (80)	49 – 70 (1.3 – 1.8)	3/4" cam coupler	1/4" (6)	20" (508)

Accessories

Model	Type	Description	For Use With
621603-6	Connection kit	Includes 6' waste oil hose with female 3/4" coupler and air supply line	67384
96268	Transmission funnel	22" x 35" funnel fits standard 61231 and 61235 funnels	62131
96548	Transmission funnel	24" x 35" transmission funnel fits standard 67384 units	67384
96269	Tool tray	Polypropylene tool tray holds tools, filters, funnels, etc. connects to down tube and handle	62131, 61235, 67384

Oil Drains and Accessories

615019-1

A professional oil drain that adjusts between 41 and 69 inches high, and includes a smooth-rolling dolly for easy and safe movement. A convenient dipstick is provided to measure contents level. This model includes the drum with a drain valve.

640058-2

Dolly for 16-gal keg.

615014

16-gal drum with shut-off valve.



615028

This oil drain has a low-profile design for use in fleet service centers. The pan is baffled to prevent spills during movement. This drain includes a heavy-duty top screen to keep tools and parts out of the drain, a pump adapter for easy connection to an evacuation pump, and a durable finish to prevent corrosion.

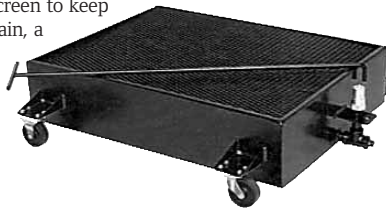

Model	Description	Height Range in	Capacity gal	Includes
OIL DRAINS				
615003- B	16-gal oil drain kit	39" – 67"	16	Funnel, screen, drum cover, dipstick
615019-1	16-gal oil drain	41" – 69"	16	Dolly, funnel, screen, drum, drum cover, dipstick, drain
615028	Low-profile oil drain	10"	20	Dolly, funnel, screen, drum, drum cover, dipstick, drain

Bulk Fluid Management



Tanks for your business

Ingersoll Rand offers a variety of bulk management services to keep your customers' fluid products flowing smoothly.

- Product consultation
- System design and manufacturing
- Installation
- Permit filing
- Project management
- On-site troubleshooting
- Preventive maintenance
- System leasing

Whether it's bulk tanks or portable dispensing units, Ingersoll Rand offers durable and reliable products for clean and waste fluid transfer applications that require bulk storage. Our double-walled units, flexible anchoring options, spill containment features, and over-spill protection devices maximize safety. And, our standard one-year warranty on systems and five-year warranty on Ingersoll Rand / ARO pumps provide added peace of mind.

For more information about Ingersoll Rand fluid solutions, please call us at (866) NSP-SERV.



Bulk Oil Tanks

Bulk Oil Tanks

Ingersoll Rand offers both horizontal and vertically configured double-walled tanks designed to meet all your bulk storage needs. Flexible anchoring options, spill containment features, and over-spill protection devices are just some of the many options that protect your workspace and the environment. And, our standard one-year warranty on systems and five-year warranty on ARO pumps provide added piece-of-mind.

Features and benefits

- Features double-walled design for greater environmental protection
- Pumps bulk fluids quickly and efficiently using high quality ARO pumps
- Totalizes fluids with an accurate digital meter
- Dispenses fluids into containers through an optional dispensing bar and spigot
- Offers fewer moving parts leading to less pump wear and to reduced maintenance costs



Model	Length in	Width Diameter in	Height in	Tank Size gal	Pump	Max Flow Rate GPM
BULK OIL TANKS						
612999-180	N/A	36	45	180	LM2203A-11-C	6
612999-250	N/A	36	60	250	LM2203A-11-C	6
612999-300	N/A	36	72	300	LM2305A-11-B	6
615-180BTD	72	26	38	180	PD05P-AAS-PGG or 666100-362-C	13 or 35
615-250BTD	72	34	38	250	PD05P-AAS-PGG	13
615-300BTD	72	40	38	300	PD05P-AAS-PGG	13

275-gal Bulk Oil Tank

Item	Quantity	Part Number	Description
1	1	622201-5	Hose assembly
2	1	P224-610	Air regulator
3	1	LM2203A-11-C	Pump
4	1	623501-5	Hose assembly
5	2	623501-2	Hose assembly
6	2	66592	1/4" turn valve
7	2	7UM4050-SR	Hose reel assembly
8	3	75366	Adapter fittings
9	2	635360-2	Metered flow guns
10	1	640153	Low-level cut-off

Lube Equipment and Accessories

Model	Category
BULK OIL TANKS	
615-180BTD	Bulk tanks, 180-gal
612999-180	Bulk tanks, 180-gal
615-250BTD	Bulk tanks, 250-gal
612999-250	Bulk tanks, 250-gal
615-300BTD	Bulk tanks, 300-gal
612999-300	Bulk tanks, 300-gal

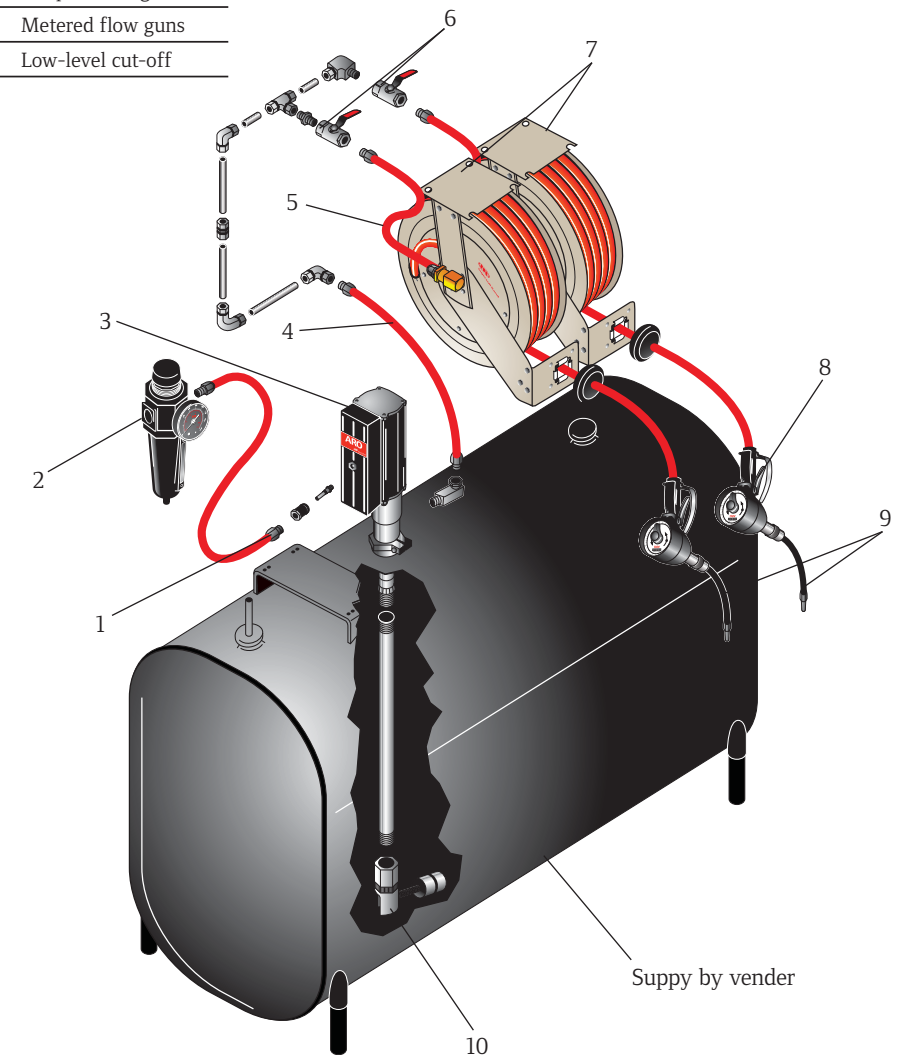

Supply by vender

55-gal Grease / Reel

Item	Quantity	Part Number	Description
1	1	LM2350E-41-B	Pump unit
2	1	75365	Adapter fitting
3	1	624401-4	Hose assembly
4	2	636042	1/4" turn valve
5	2	7UH3050-SR	Hose reel assembly
6	2	636088	Z-swivel
7	2	636111	Grease control handles
8	2	624401-4	Hose assembly
9	1	640015-1	Follower assembly
10	1	94422	Drum assembly
11	1	622201-3	Hose assembly
12	1	75364	Adapter fitting
13	1	P224-610	Air regulator

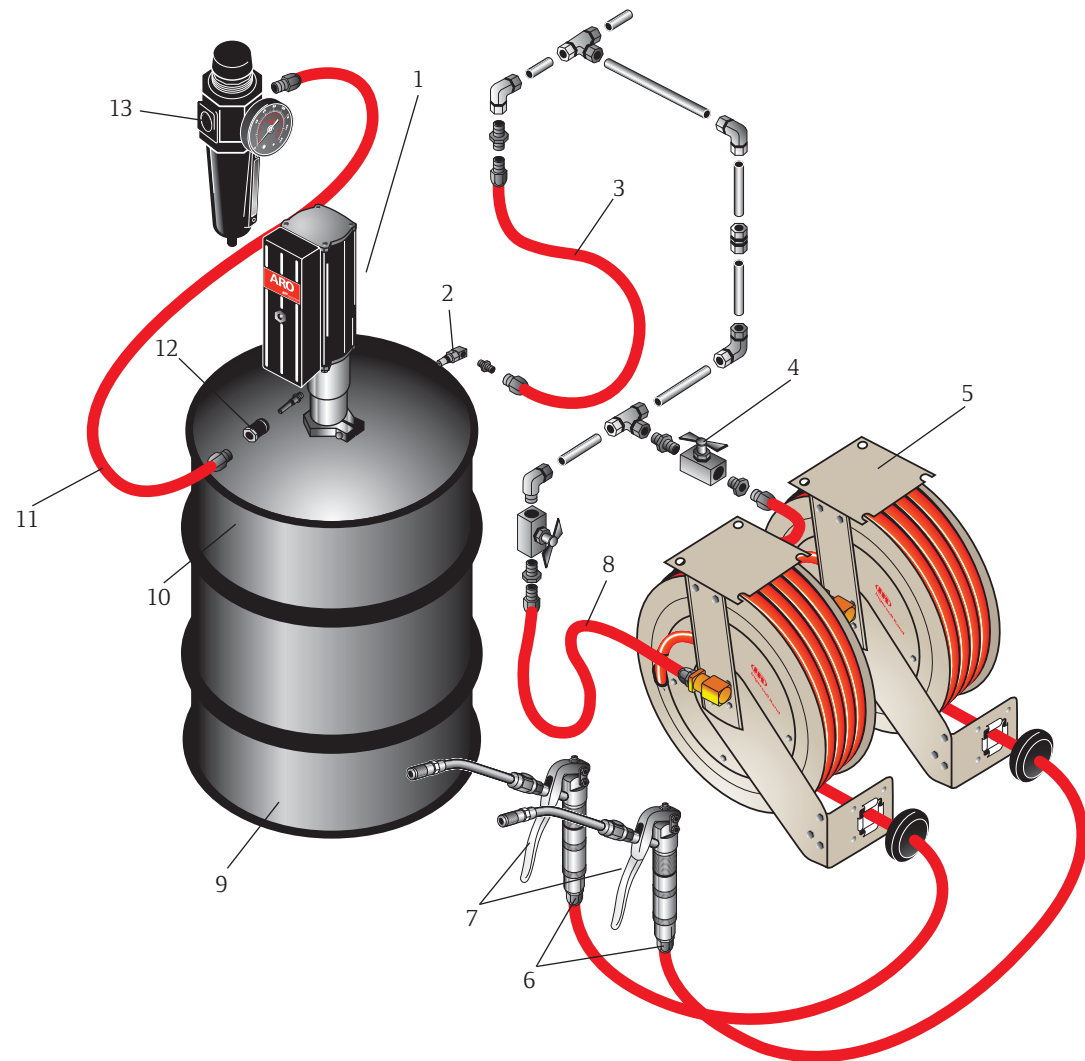

120-lb Drum Pump / Reel Assembly

Item	Quantity	Part Number	Description
1	1	LM2250E-31-B	Pump unit
2	1	Y43-233C	T union
3	1	624401-4	Hose assembly
4	1	636042	1/4" turn valve
5	1	7UH3025-SR	Hose reel assembly
6	1	624401-4	Hose assembly
7	1	636088	Z-swivel
8	1	636111	Grease control handles
9	1	640165	Drum follower plate
10	1	94421	Drum cover
11	1	622201-3	Hose assembly
12	1	75364	Adapter fitting
13	1	P224-610	Air regulator

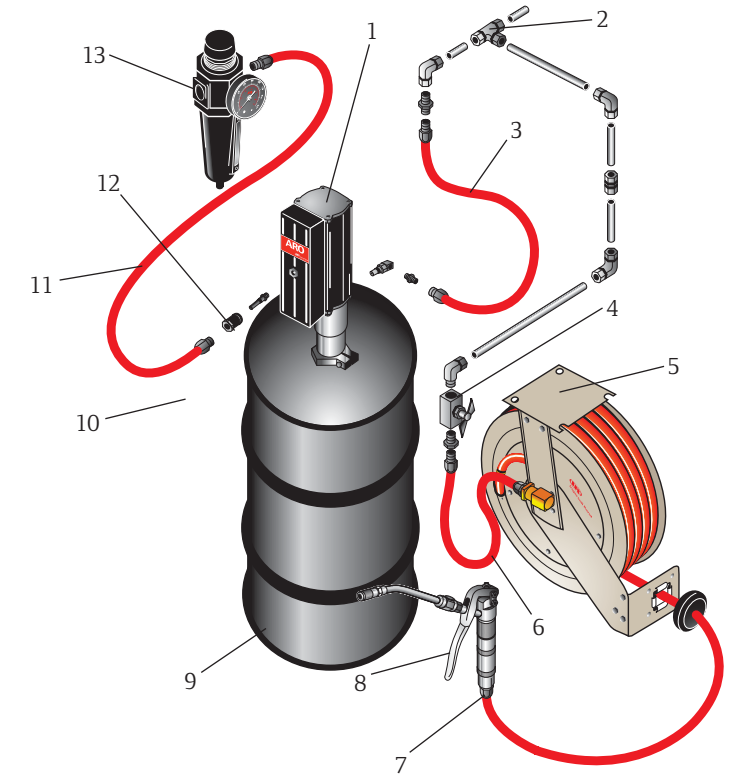

55-gal Pump / Reel

Item	Quantity	Part Number	Description
1	1	61601	55-gal drum kit
2	1	Y27-55-C	Adapter fitting
3	1	LM2203A-11-C	Pump
4	1	61113	Pump mounting bracket
5	1	75364	Adapter fitting
6	1	622201-3	Air hose
7	1	P224-60	Air regulator
8	1	66592	1/4" turn valve
9	1	623501-2	Hose assembly
10	1	7UM4050-SR	Hose reel assembly
11	1	635360-2	Metered flow control
12	1	75366	Adapter fitting

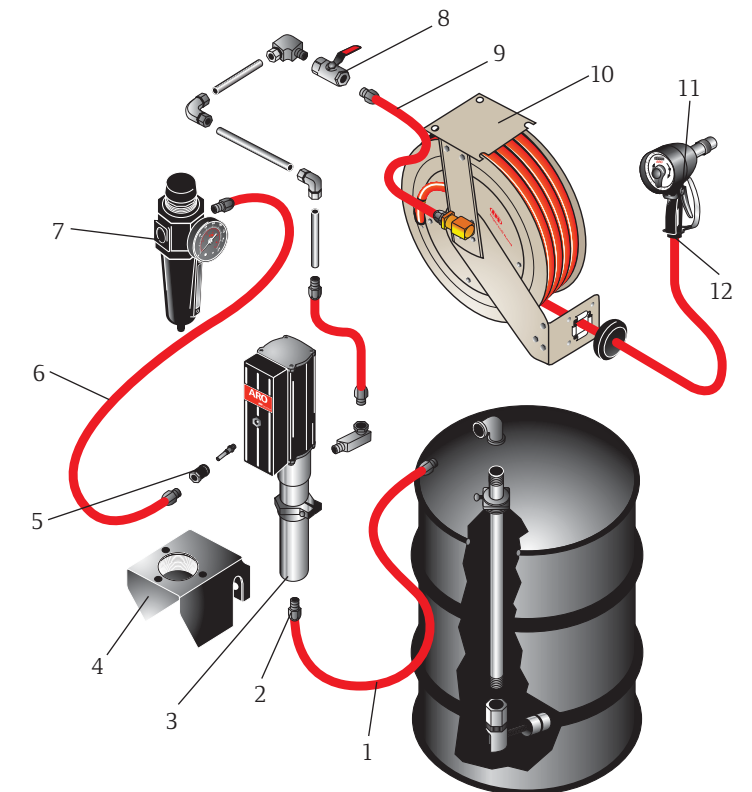

Warranty: Air Systems Components Lubrication Equipment

Air Systems Components Warranty

Ingersoll Rand Fluid Products warrants to the original-use purchaser of the Ingersoll Rand / ARO air systems components depicted in this catalog that Ingersoll Rand will repair or replace, free of charges, including return shipping costs within the continental United States of America, any such product that under normal use and service proves defective in material or workmanship, as determined by Ingersoll Rand inspection, five years from date of purchase, provided the claimed defective product, or part thereof, is promptly returned to the Ingersoll Rand Service Repair Center or a factory-authorized service repair center, with transportation charges prepaid.

If Ingersoll Rand inspection discloses no defect in material or workmanship, repair or replacement and return will be made at customary charges.

The foregoing warranty supersedes, voids, and is in lieu of all or any other warranties, expressed or implied, and no warranty of merchantability or fitness for particular purpose is intended or made. The sole obligation of Ingersoll Rand and the sole remedy of the original-use purchaser is as stated above and in no event shall Ingersoll Rand be liable for any special, direct, indirect, incidental, consequential; or other damages or expenses of any nature including, without limitation, loss of profits or production time incurred by the original-use purchaser or any other party.

Lubrication Equipment Warranty

Ingersoll Rand warrants to the original-use purchaser of the products depicted in this catalog that Ingersoll Rand will repair or replace, free of charges, including return shipping costs within the continental United States of America, any such product that under normal use and service proves defective in material and workmanship, as determined by Ingersoll Rand inspection, within (A) one year from date of purchase of said products, other than the following, (B) five years from date of purchase of LM and LP Series pumps, (C) five years from date of purchase of a diaphragm pump, and (D) five years from date of purchase of Ingersoll Rand / ARO-manufactured swivels, non-metered control handles, 4-1/4", 6", 8" pumps, drains, follower plates, tie-downs, siphon tubes, and drum covers, provided the claimed defective product, or part thereof, is promptly returned to the Ingersoll Rand factory or Customer Service Center with transportation charges prepaid.

This warranty does not cover failure of parts or components due to normal wear or damage, or wear that in the judgement of Ingersoll Rand / ARO arises from misuse, abrasion, corrosion, negligence, accident, substitution of non-Ingersoll Rand / ARO parts, faulty installation, or tampering.

If Ingersoll Rand inspection discloses no defect in material or workmanship, repair or replacement and return will be made at customary charges.

Equipment not covered by Ingersoll Rand warranty: accessories or components of equipment sold by Ingersoll Rand that are not manufactured by Ingersoll Rand (such as switches, hoses, meters, etc.) are subject to the warranty, if any, of their manufacturer. Ingersoll Rand will provide the purchaser with reasonable assistance in making such claims.

The foregoing warranty supersedes, voids, and is in lieu of all or any other warranties, expressed or implied, and no warranty of merchantability or fitness for particular purpose is intended or made. The sole obligation of Ingersoll Rand and the sole remedy of the original-use purchaser is as stated above and in no event shall Ingersoll Rand be liable for any special, direct, indirect, incidental, consequential, or other damages or expenses of any nature including, without limitation, loss of profits or production time incurred by the original-use purchaser or any other party.

Contact Information

United States

Fluid Technical Center
PO Box 151
One ARO Center
Bryan, OH 43506-0151
Telephone: (419) 636-4242
Fax: (419) 633-1674

Distribution Center
510 Hester Drive
White House, TN 37188
Telephone: (615) 223-4500
Fax: (615) 223-4500

Marketing/Sales & Distribution Centers
Ingersoll Rand Productivity Solutions
1467 Route 31 South
Annandale, NJ 08801
Telephone: (908) 526-1000
Fax: (908) 526-1000

Canada

Marketing, Sales & Distribution Center
Ingersoll Rand Canada Inc.
51 Worcester Road
Toronto, Ontario M2H 4K2
Telephone: (416) 213-4500
Fax: (416) 213-4510

Customer Service
Toll Free Tel: (877) 999-9073
Toll Free Fax: (888) 422-2258
Local Fax: (416) 213-4506

Latin America

Marketing/Sales/Service Headquarters
Ingersoll Rand Company
730 N.W. 107th Avenue
Suite 300
Miami, FL 33172-3107
USA
Telephone: (305) 559-0500
Fax: (305) 222-0864

Brasil

Ingersoll-Rand do Brasil Ltda.
Tool & Hoist Division
Av. Dr. Cardoso de Melo, 1855
cj. 152-04548-005 Sao Paulo, SP
Brasil
Telephone: (55) 11 3049-8900
Fax: (55) 11 3846-4985

Chile

Ingersoll Rand Chile
Nueva Tajamar 555, 15th fl.
Las Condes, Santiago
Chile
Telephone: (56) 2 339-7939
Fax: (56) 2 339-7940

Mexico

Ingersoll Rand de Mexico S.A. de C.V.
Tool & Hoist Division
Blvd. Centro Industrial #11
54090 Tlaxiaco, Tlaxiaco, Edo. de Mexico
Mexico
Telephone: (52) 565-3061
Fax: (52) 565-3072

Middle East/Africa

Tool & Hoist Division Headquarters
and **European Customer Centre**
Ingersoll Rand
Zone du Chêne
BP 62
91100 Evry-sous-Bois C

France
Telephone: +33 (0) 1 30 07 68 00
Fax: +33 (0) 1 30 07 69 80

United Kingdom

Ingersoll Rand Distribution Centre
Swan Lane
Hindley Green
Wigan
Lancashire WN2 4EZ
England
Telephone: +44 (0) 1942 257131
Fax: +44 (0) 1942 526255

Asia/Pacific

Marketing/Sales/Service Headquarters
Ingersoll Rand Asia Pacific Ltd.
23/F, 625 King's Road
North Point
Hong Kong
Telephone: (852) 2527-0183
Fax: (852) 2529-5976

Australia

Ingersoll Rand Australia Ltd.
1 Hartnett Drive
Geelong, Victoria 3198
Australia
Telephone: (61) 3 9554 1600
Fax: (61) 3 9554 1611

India

Ingersoll Rand Wadco Tools Ltd.
37/38, Phase 4
Salad Industrial Area
Gurgaon Road 201 010 (UP)
India
Telephone: (91) 0120-4771-001 /2/3/4
Fax: (91) 0120-4771-005

For additional specific information on Ingersoll-Rand locations in Europe and Asia, visit our website at: www.irtools.com.



Disclaimer: Nothing contained within this brochure is intended to extend any warranty or representation, expressed or implied, regarding the products described herein. Any such warranties or other terms or conditions of the sale of products shall be in accordance with Ingersoll Rand Standard Terms and Conditions of Sale for such products which are available upon request.

Product improvement is a continuing goal at Ingersoll-Rand. Designs and specifications are subject to change without notice or obligation.

*The Ingersoll Rand corporate identities are changing. While most photography reflects previous symbols and logos, you will soon see our new look.

Distributed by:



Ingersoll Rand Industrial Technologies provides products, services and solutions that enhance our customers' energy efficiency, productivity and operations. Our diverse and innovative products range from complete compressed air systems, tools and pumps to material and fluid handling systems and environmentally friendly microturbines. We also enhance productivity through solutions created by Club Car®, the global leader in golf and utility vehicles for businesses and individuals.

arozone.com
(800) 495-0276